

# Infotech

## English for computer users

Third  
Edition

Electronic Version:  
Buldoz@r(2ZI-06)

Cambridge  
Professional  
English

**Student's Book**

Santiago  
Remacha Esteras

**CAMBRIDGE**  
UNIVERSITY PRESS

# Infotech

## English for computer users

Third edition

---

**Student's Book**

---

Santiago

Remacha Esteras



**CAMBRIDGE**  
UNIVERSITY PRESS

CAMBRIDGE UNIVERSITY PRESS

Cambridge, New York, Melbourne, Madrid, Cape Town, Singapore, São Paulo

Cambridge University Press

The Edinburgh Building, Cambridge CB2 2RU, UK

[www.cambridge.org](http://www.cambridge.org)

Information on this title: [www.cambridge.org/9780521754286](http://www.cambridge.org/9780521754286)

© Cambridge University Press 1993, 1999, 2003

This publication is in copyright. Subject to statutory exception and to the provisions of relevant collective licensing agreements, no reproduction of any part may take place without the written permission of Cambridge University Press.

First published 1993

Second edition 1999

Third edition 2003

5th printing 2006

Printed in Dubai by Oriental Press

*A catalogue record for this publication is available from the British Library*

ISBN-13 978-0-521-75428-6 Student's Book

ISBN-10 0-521-75428-3 Student's Book

ISBN-13 978-0-521-75429-3 Teacher's Guide

ISBN-10 0-521-75429-1 Teacher's Guide

ISBN-13 978-0-521-75430-9 Audio Cassette

ISBN-10 0-521-75430-5 Audio Cassette

ISBN-13 978-0-521-75431-6 Audio CD

ISBN-10 0-521-75431-3 Audio CD

ISBN-13 978-0-521-53288-4 CD Workbook

ISBN-10 0-521-53288-4 CD Workbook

# Contents

<b>Map of the book</b>	<b>iv</b>		
<b>Thanks and Acknowledgements</b>	<b>viii</b>		
<hr/>			
<b>Section 1 Computers today</b>	<b>1</b>	<b>Section 5 Creative software</b>	<b>87</b>
<b>Unit 1</b> <i>Computer applications</i>	2	<b>Unit 19</b> <i>Graphics and design</i>	88
<b>Unit 2</b> <i>Computer essentials</i>	7	<b>Unit 20</b> <i>Desktop publishing</i>	93
<b>Unit 3</b> <i>Inside the system</i>	11	<b>Unit 21</b> <i>Web design</i>	97
<b>Unit 4</b> <i>Bits and bytes</i>	16	<b>Unit 22</b> <i>Multimedia</i>	101
<b>Unit 5</b> <i>Buying a computer</i>	20	<hr/>	
<hr/>			
<b>Section 2 Input/output devices</b>	<b>25</b>	<b>Section 6 Programming</b>	<b>106</b>
<b>Unit 6</b> <i>Type, click and talk!</i>	26	<b>Unit 23</b> <i>Program design</i>	107
<b>Unit 7</b> <i>Capture your favourite image</i>	31	<b>Unit 24</b> <i>Languages</i>	111
<b>Unit 8</b> <i>Viewing the output</i>	35	<b>Unit 25</b> <i>The Java revolution</i>	114
<b>Unit 9</b> <i>Choosing a printer</i>	39	<b>Unit 26</b> <i>Jobs in computing</i>	118
<b>Unit 10</b> <i>I/O devices for the disabled</i>	44	<hr/>	
<hr/>			
<b>Section 3 Storage devices</b>	<b>49</b>	<b>Section 7 Computers tomorrow</b>	<b>122</b>
<b>Unit 11</b> <i>Magnetic drives</i>	50	<b>Unit 27</b> <i>Electronic communications</i>	123
<b>Unit 12</b> <i>Optical breakthrough</i>	54	<b>Unit 28</b> <i>Internet issues</i>	128
<hr/>			
<b>Section 4 Basic software</b>	<b>59</b>	<b>Unit 29</b> <i>LANs and WANs</i>	133
<b>Unit 13</b> <i>Operating systems</i>	60	<b>Unit 30</b> <i>New technologies</i>	138
<b>Unit 14</b> <i>The graphical user interface</i>	64	<hr/>	
<b>Unit 15</b> <i>A walk through word processing</i>	68	<b>Notes for Student A</b>	<b>143</b>
<b>Unit 16</b> <i>Spreadsheets</i>	74	<b>Notes for Student B</b>	<b>147</b>
<b>Unit 17</b> <i>Databases</i>	77	<b>Glossary</b>	<b>151</b>
<b>Unit 18</b> <i>Faces of the Internet</i>	82	<b>Acronyms and abbreviations</b>	<b>158</b>
<hr/>			
		<b>Trademarks</b>	<b>160</b>

# Map of the book

	UNIT	LISTENING	READING
<b>Section 1</b> <b>Computers today</b>	<b>1</b> <i>Computer applications</i>	<i>Using computers at work</i>	<i>What can computers do?</i>
	<b>2</b> <i>Computer essentials</i>	<i>Types of computer systems</i>	<i>What is a computer?</i>
	<b>3</b> <i>Inside the system</i>	<i>Describing a computer system</i>	<i>What is inside a PC system?</i>
	<b>4</b> <i>Bits and bytes</i>		<i>Units of memory: bits, bytes, KB, MB, GB; binary system</i> <i>Bits for pictures</i>
	<b>5</b> <i>Buying a computer</i>	<i>Buying a computer in a shop</i>	<i>Computers for particular work situations</i>
<b>Section 2</b> <b>Input/output devices</b>	<b>6</b> <i>Type, click and talk!</i>	<i>Different input devices</i> <i>Voice input</i>	<i>About the keyboard</i> <i>Mouse actions</i>
	<b>7</b> <i>Capture your favourite image</i>	<i>Types of scanners</i>	<i>The eyes of your PC: scanner, digital camera and camcorder</i> <i>Facts and opinions in advertisements</i>
	<b>8</b> <i>Viewing the output</i>	<i>Health and safety</i>	<i>The monitor: CRTs and flat screens</i>
	<b>9</b> <i>Choosing a printer</i>	<i>Ink-jet printers</i>	<i>Types of printers</i> <i>Adverts for printers</i>
	<b>10</b> <i>I/O devices for the disabled</i>	<i>Adaptive technology for the blind</i>	<i>Computers for the disabled</i>
<b>Section 3</b> <b>Storage devices</b>	<b>11</b> <i>Magnetic drives</i>	<i>Buying a removable drive</i>	<i>Types of drives</i> <i>Technical details</i>
	<b>12</b> <i>Optical breakthrough</i>	<i>What's a CD-ROM?</i>	<i>Optical disks and drives</i>
<b>Section 4</b> <b>Basic software</b>	<b>13</b> <i>Operating systems</i>	<i>System utilities (screen saver, virus detectors, etc.)</i>	<i>Operating systems: MS-DOS, Windows, Mac OS, OS/2 Warp, UNIX, Linux</i>
	<b>14</b> <i>The graphical user interface</i>	<i>Microsoft Windows</i>	<i>GUIs</i>
	<b>15</b> <i>A walk through word processing</i>	<i>The 'cut and paste' technique</i>	<i>Word-processing facilities</i> <i>Writing tools: spell checker, thesaurus, grammar checker</i>

SPEAKING	WRITING	GRAMMAR	VOCABULARY
<i>How are/were computers used in your school?</i>	<i>Specific computer applications</i>	<i>Present simple passive</i> Data + 3rd person singular verb	<i>Word fields: computers in education, banks, sports, airports, medicine, factories, entertainment</i>
<i>The configuration of your PC: What do you use your computer for?</i>		<i>Compound adjectives</i>	<i>Basic terminology: hardware, software, peripherals, input/output devices, central processing unit</i>
<i>Your ideal computer system</i>		<i>Contextual reference</i> <i>Defining relative clauses</i>	<i>Acronyms and abbreviations: CPU, ALU, RAM, ROM, MHz, GHz, bit, SIMM, DIMM</i>
	<i>Translations</i>		<i>Prefixes: deci-, hexadeci-, kilo-, mega-, giga-, mini-, micro-, bi-, tri-, mono-, multi-</i>
<i>Role play: buying a computer</i>	<i>Recommending a computer to a friend</i>		<i>Vocabulary tree: terminology</i>
<i>Describing and identifying input devices</i>	<i>Describing a joystick</i>	<i>for + -ing</i> <i>which + verb</i> <i>which/that is used + to + inf.</i>	<i>Word field: input devices</i> <i>Symbols and special keys</i> <i>Mouse actions: click, drag, grab</i>
	<i>Completing a digital camera advertisement</i>	<i>Comparatives and superlatives</i>	<i>Word building: suffixes</i> <i>Persuasive words in advertisements</i>
<i>Describing your computer screen</i>	<i>Explaining tables</i>	<i>Instructions and advice: imperative, should, ought to</i>	<i>Monitors: resolution, pixels, display, hertz, VGA, LCD, CRT, phosphors</i>
<i>Describing the printer you would like to use</i>	<i>The pros and cons of the printer you use</i>	<i>Discourse cohesion: reference signals and linking devices</i> <i>Comparison: revision</i>	<i>Types of printers: dot-matrix, ink-jet, thermal, laser printers, imagesetters, plotters</i>
<i>Discussing devices for computer users with vision and mobility limitations</i>	<i>A letter asking for information about I/O equipment for disabled workers</i>	<i>Noun phrases; modifiers</i>	<i>Braille, speech synthesizers, OCR, voice recognition, eye-gaze system, sip &amp; puff, touch screen, switch, screen-pointing device</i>
<i>How to protect your data</i>		<i>Instructions with must/must not</i>	<i>Floppy, hard disk, tape drive, removable cartridge, track, sector, format, magnetic, read/write heads, directory, access time, data transfer rate, fragmentation</i> <i>Suffixes: -ic, -ism, -ize, -izable, -er</i>
<i>Choosing the most suitable storage devices for specific purposes</i>	<i>Completing a table with relevant information about optical disks</i>	<i>Discourse cohesion: reference signals and connectors and modifiers</i>	<i>Acronyms and abbreviations: laser, ms, CD-ROM, CD-R, CD-RW, DVD-ROM, DVD-R</i>
<i>What's the function of the operating system?</i>		<i>Countable and uncountable nouns</i>	<i>Operating systems, utilities</i> <i>Abbreviations: OS, MS-DOS, IBM</i>
	<i>A summary</i>	<i>Ways of reducing sentences</i>	<i>GUIs: windows, icons, pull-down menus, pointer, user-friendly, folder</i>
<i>Comparing word processors</i>	<i>Describing the process of moving text</i>	<i>Sequencers: first, now, next, finally</i>	<i>WP programs: edit, format, search, replace, indent, WYSIWYG, clipboard, typeface</i>

	UNIT	LISTENING	READING
<b>Section 4</b> <b>Basic software</b>	<b>16</b> <i>Spreadsheets</i>	<i>Spreadsheets programs</i>	
	<b>17</b> <i>Databases</i>	<i>Mail merging</i>	<i>Basic features of database programs</i>
	<b>18</b> <i>Faces of the Internet</i>	<i>What's the Internet?</i>	<i>Internet software: e-mail, Web browser, newsreader, IRC/chats, FTP, conferencing, Telnet</i>
<b>Section 5</b> <b>Creative software</b>	<b>19</b> <i>Graphics and design</i>	<i>A basic tool palette</i>	<i>Computer graphics</i>
	<b>20</b> <i>Desktop publishing</i>	<i>Fonts, a necessary part of DTP</i>	<i>What is 'desktop publishing'?</i>
	<b>21</b> <i>Web design</i>	<i>How to plan, design and publish a website</i>	<i>Creating web pages</i>
	<b>22</b> <i>Multimedia</i>	<i>A multimedia system Software: revision</i>	<i>Multimedia magic! Multimedia on the Web: recognizing file formats</i>
<b>Section 6</b> <b>Programming</b>	<b>23</b> <i>Program design</i>	<i>Steps in producing a program</i>	<i>Programming languages</i>
	<b>24</b> <i>Languages</i>	<i>C language</i>	<i>A short description of Visual BASIC</i>
	<b>25</b> <i>The Java revolution</i>	<i>A brief history of Java (gap dictation)</i>	<i>What is Java?</i>
	<b>26</b> <i>Jobs in computing</i>	<i>A job interview</i>	<i>Job advertisements</i>
<b>Section 7</b> <b>Computers tomorrow</b>	<b>27</b> <i>Electronic communications</i>	<i>Interview about cybercafés</i>	<i>Channels of communication</i>
	<b>28</b> <i>Internet issues</i>	<i>Cyberspace: benefits and dangers for children</i>	<i>Security and privacy on the Internet Hackers!</i>
	<b>29</b> <i>LANs and WANs</i>	<i>A computer network</i>	<i>Network configurations Worldwide communications</i>
	<b>30</b> <i>New technologies</i>	<i>Palmtops</i>	<i>New products</i>

	SPEAKING	WRITING	GRAMMAR	VOCABULARY
	<i>Visual representations versus spreadsheets</i>	<i>Producing an invoice with a spreadsheet program</i>		<i>Spreadsheets:</i> cell, column, row, formula, invoice, expenses
		<i>Writing a standard letter to clients</i>	<i>Plurals</i>	<i>Databases:</i> field, record, file, sort, update
	<i>Internet applications</i> <i>Holidays: Questionnaire</i>	<i>Replying to an e-mail message</i>	be going to + <i>infinitive</i>	Modem, Internet service provider, Web browser, newsgroup, IRC, online chatting, Telnet, FTP, HTML, hypertext, link, URL, intranet
	<i>Describing 2-D and 3-D graphics</i>		<i>Gerunds (-ing nouns)</i>	<i>Graphics:</i> patterns, primitives, attributes, dithering, zoom, rotation, scaling, rendering
	<i>Exchanging information about computers for newspapers</i>	<i>A letter to a newspaper</i>	<i>Affixation, conversion, compounding</i>	<i>DTP packages:</i> layout application, imagesetter, service bureau, font software design, import
	<i>Answering questions about a typical home page: Questionnaire</i>	<i>Creating your own Web pages</i>	<i>Modal verbs</i>	<i>Web design:</i> website, home page, HTML tag, Web editor, hyperlink, <i>hyper-</i>
		<i>Describing the process of making a movie on a PC</i>	<i>Conditional clauses</i>	<i>Multimedia PC:</i> sound card, MIDI, animation, video editing, <i>File formats:</i> .htm, .gif, .jpg, .mp3, .mpg
			<i>Infinitive constructions</i>	<i>Programming:</i> flowchart, compiler, debug, bugs, machine code <i>Prefixes and suffixes</i>
	<i>Sharing information about computer languages</i>	<i>Describing C language</i>	<i>The passive</i>	Visual BASIC, COBOL, LOGO, Pascal, C, SQL, Voice XML
	<i>Personal experience with computers</i>		<i>The past simple</i>	<i>Java applet, plug-in, interpreter, download</i>
	<i>Discussing personal qualities and professional skills</i>	<i>Letter applying for a job</i>	For, since <i>and</i> ago <i>Past simple and present perfect</i>	<i>Jobs:</i> programmer, DTP operator, computer operator
	<i>Planning a cybercafé with a partner</i>	<i>Mini-project: Designing a cybercafé</i>		<i>Data communication systems:</i> fax, teletext, the Internet, BBS <i>Prefixes:</i> tele-, auto-, inter-, trans-
	<i>Discussing computer crime, security, privacy, Internet ratings, etc.</i>	<i>A summary of a discussion in small groups</i>	<i>Past simple (revision)</i>	<i>Internet security:</i> user name, password, encryption, decryption, hacker, cookies, digital certificate, filter, computer crimes
	<i>Describing two networks connected via satellite</i>	<i>Descriptions of network connections</i>	<i>Prepositional phrases of 'reference'</i>	<i>Networks:</i> LAN, WAN, node, transceiver, protocol, token, gateway, ADSL, fibre optics
	<i>Discussing the advantages and limitations of handheld computers</i>	<i>Making predictions</i> <i>The future continuous</i>	will + <i>infinitive</i> mobile phone, virtual reality, <i>The future perfect</i> may/might/could + <i>inf.</i>	<i>New technologies:</i> WAP, UMTS, Internet TV, wireless, Bluetooth palmtop, PDA

## Thanks

The author would especially like to express his gratitude to Paz, Marina and Violeta. My special thanks to Will Capel for his help. Thanks are also due to teachers and students of Instituto Pilar Lorengar, Zaragoza. Angel Benedí for his generous advice on technical aspects. Ben Graham for editing the typescript.

## Acknowledgements

The author and publishers are grateful to the authors, publishers and others who have given permission for the use of copyright material identified in the text. It has not been possible to identify the sources of all the material used and in such cases the publishers would welcome information from copyright owners.

(p = page; t = top; c = centre; b = bottom; l = left; r = right)

pp 45-46: Adapted extract from 'Computers for the disabled' by Joseph J. Lazzaro, reprinted with permission from the June 1993 issue of *BYTE* magazine © by McGraw-Hill Inc. New York NY. All rights reserved; pp 69, 72, 93-94: Reprinted from *Understanding Computers* by Nathan Shedroff, J. Sterling Hutto, and Ken Fromm by permission of SYBEX Inc. 0-7821-1284-X, Copyright 1993, SYBEX Inc. All rights reserved; p 92: Extract from *Introduction to Computer Graphics* by permission of Hewlett-Packard Limited; p 102: Permission granted from the article 'Upgrading to Multimedia', *PC Upgrade*, June 1993 issue, a publication of Bedford Communications, Inc., New York, New York.

p 2 tl The Stock Market/A. Skelley; p 2 tr Tony Stone Images/Walter Hodges; p2 bl Peter Menzel/Science Photo Library; p 2 br Sporting Pictures (UK) Limited; p 5 Pictor International; p 10 Volker Sieger Science Photo Library. p 12 Pentium® 4 processor reproduced with kind permission of Intel Corporation, p 12 Taheshi Takahara/Science Photo Library; p 20 tr PC World; pp 20, bl, br, 62t, 64 reproduced by kind permission of Apple Computers UK Limited; pp 22r, 23 1, 35, 37, 61c © Compaq Computers Limited, p 31 t,b Canon UK Ltd, p 34 Eastman Kodak Company, p 35 Epson (UK) Limited; p 41 Hewlett-Packard Limited; p 44 tl Sally Lancaster/Format Photographers; p 44 tr Richard T. Nowitz/Science Photo Library; p 44 bl Action for Disability, Newcastle-upon-Tyne/Simon Fraser/Science Photo Library; p 44 br De Repentigny, Publiphoto Diffusion/Science Photo Library; p 45 Peter Menzel/Science Photo Library; p 46 l Sally Lancaster/Format Photographers; p 46 r AbilityNet; p 50 Iomega Corporation, pp 50, 55, 62 t IBM (UK) Limited; p 54 b The Stock Market/Jean Miele; p 57 Greg Evans International, pp 61 t, 61 c, 100, 112 Box shots reprinted with permission from Microsoft Corporation; pp 66, 68, 71, 72 t, c, b, 74, 76 b, 82, 84 Screen shots reprinted by permission from Microsoft Corporation; Tony Stone Images/Dan Bosler; p 85 Netscape Communicator Browser window© 1999 Netscape Communications Corporation; p 86 Eudora Qualcomm Incorporated. Eudora is the registered trademark of QUALCOMM Incorporated; p 93 Screen Shot of Adobe® Pagemaker® reproduced with the permission of Adobe Systems Europe Limited, p 97 screen shot reproduced with permission of Yahoo! Inc. © 2000 by Yahoo! Inc. YAHOO! and the YAHOO! logo are trademarks of Yahoo! Inc., p 114 Java Applets © Sun Microsystems, Inc. All Rights reserved. Used by permission, p 119 Telegraph Colour Library/V.C.L./Nick Clements; p 121 John Walmsey Photo-Library; p 123 PowerStock/Zefa/Index; p 125 l reproduced with the permission of, and is the copyright of, British Telecommunications PLC; p 125 r Screen from Teletext on ITV and Channel Four, by permission of Teletext Limited; p 127 Tony Stone Images/Andrew Errington; p 130 Cyberpatrol screen shot with permission of SurfControl Inc., p 132 CERT Logo reproduced by permission of CERT® Coordination Center, p 138 tr NASA/Science Photo Library; p 138 br WorldGate Incorporated; p 141 Psion PLC; p 142 Cartoon by Patrick Blower. Photographs on pp 7, 59 t, 102, 113, 136, by Nigel Luckhurst.

Picture research by Sandie Huskinson-Rolfe of PHOTOSEEKERS and Vivien Tweed.



# Computers today

Unit		page
1	<i>Computer applications</i>	2
2	<i>Computer essentials</i>	7
3	<i>Inside the system</i>	11
4	<i>Bits and bytes</i>	16
5	<i>Buying a computer</i>	20

## Learning objectives

***In this section you will learn how to:***

- talk and write about computer applications in everyday life
- recognize the basic components of a computer system and understand their functions
- identify different types of computers
- understand the functions of the CPU and the main memory
- understand the units of memory (bits, bytes, KB, MB, GB)
- build up new words by using prefixes
- buy a computer from a shop
- use synonyms, acronyms and abbreviations when talking about computers.

# Unit 1 *Computer applications*

## 1 Match the pictures

**A** Computers have many applications in a great variety of fields. Look at these photographs of different situations and match them with texts 1 to 4 below.



1 Computers can help students perform mathematical operations and solve difficult questions. They can be used to access the Internet, teach courses such as computer-aided design, language learning, programming, mathematics, etc.

PCs (personal computers) are also used for administrative purposes: for example, schools use databases and word processors to keep records of students, teachers and materials.

- 2 Race organizers and journalists rely on computers to provide them with the current positions of riders and teams in both the particular stages of the race and in the overall competition.

Workstations in the race buses provide the timing system and give up-to-the-minute timing information to TV stations. In the press room several PCs give real-time information on the state of the race. Computer databases are also used in the drug-detecting tests for competitors.

- 3 Computers store information about the amount of money held by each client and enable staff to access large databases and to carry out financial transactions at high speed. They also control the automatic cash dispensers which, by the use of a personal coded card, dispense money to clients.

- 4 Airline pilots use computers to help them control the plane. For example, monitors display data about fuel consumption and weather conditions.

In airport control towers, computers are used to manage radar systems and regulate air traffic.

On the ground, airlines are connected to travel agencies by computer. Travel agents use computers to find out about the availability of flights, prices, times, stopovers and many other details.

**B Match these captions with the pictures.**

*Using an automatic cash dispenser*

*In education, computers can make all the difference*

*Organizing the Tour de France demands the use of computer technology*

*Controlling air traffic*

**C When you read texts like these, you don't always need to understand every word. But there are words which you can guess from the context. Look at these words. Are they nouns (n), verbs (v) or adjectives (adj)?**

1 workstation ..... 2 data ..... 3 perform ..... 4 automatic ..... 5 monitor .....  
6 financial ..... 7 store ..... 8 connected ..... 9 word processor ..... 10 large .....

**Now find the words in texts 1 to 4, and match them with the meanings below.**

a information

g self-acting, mechanical

b execute (do)

h screen

c connected with money

i powerful computer usually

d keep (save)

connected to a network

e massive

j program used for text manipulation

f linked

**D Look at text 1 again and discuss these questions.**

- How are/were computers used in your school?
- What other areas of study would benefit from the introduction of computers?

## 2 Listening

 Listen to these people talking about how they use computers at work and write each speaker's job in the table.

electrical engineer    secretary    librarian    composer

<i>Speaker</i>	<i>Job</i>	<i>What they use computers for</i>
1		
2		
3		
4		

Now listen again and write what each speaker uses their computer for.

## 3 Reading

- A** Write a list of as many uses of the computer, or computer applications, as you can think of.
- B** Now read the text below and underline any applications that are not in your list.

### *What can computers do?*

Computers and microchips have become part of our everyday lives: we visit shops and offices which have been designed with the help of computers, we read magazines which have been produced on computer, we pay bills prepared by computers. Just picking up a telephone and dialling a number involves the use of a sophisticated computer system, as does making a flight reservation or bank transaction.

We encounter daily many computers that spring to life the instant they're switched on (e.g. calculators, the car's electronic ignition, the timer in the microwave, or the programmer inside the TV set), all of which use chip technology.

What makes your computer such a miraculous device? Each time you turn it on, it is a tabula rasa that, with appropriate hardware and software, is capable of doing anything you ask. It is a calculating machine that speeds up financial calculations. It is an electronic filing cabinet which manages large collections of data such as customers' lists, accounts, or inventories. It is a magical typewriter that allows you to type and print any kind of document — letters, memos or legal documents. It is a personal communicator that enables you to interact with other computers and with people around the world. If you like gadgets and electronic entertainment, you can even use your PC to relax with computer games.

## 4 Language work: The present simple passive

Look at the **HELP** box and then read the sentences.

Fill in the blanks with the correct form of the verbs in brackets.

### Example

Houses (design) ..... with the help of computers.

*Houses are designed with the help of computers.*

- 1 Various terminals (connect) ..... to this workstation.
- 2 Microcomputers (know) ..... as 'PCs'.
- 3 Magazines (typeset) ..... by computers.
- 4 When a particular program is run, the data (process) ..... by the computer very rapidly.
- 5 The Web (use) ..... to search for information and buy products online.
- 6 The drug-detecting test in the Tour de France (support) ..... by computers.
- 7 All the activities of the computer system (coordinate) ..... by the central processing unit.
- 8 In some modern systems information (hold) ..... in optical disks.

### HELP box

#### The present simple passive

- You form the present simple passive with *am/is/are* + past participle, e.g.:
  - *This program **is written** in a special computer language.*
  - *Programs and data **are usually stored** on disks.*
- Remember that the word *data* takes a singular verb (3rd person singular) when it refers to the information operated on in a computer program.
  - *The data **is** ready for processing.*



*Computers have revolutionized the design process*

## 5 Other applications

- A** In small groups, choose one of the areas in the diagram below and discuss what computers can do in this area.

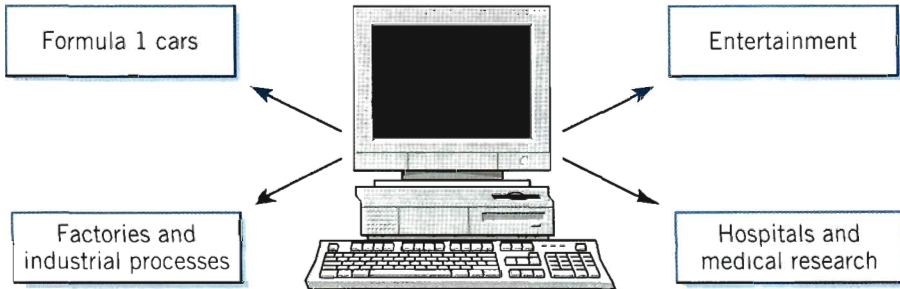

### Useful words

Formula 1: *racing car, car body, design, mechanical parts, electronic components, engine speed*

Entertainment: *game, music, animated image, multimedia, encyclopedia*

Factories: *machinery, robot, production line, computer-aided manufacturing software*

Hospitals: *patients, medical personnel, database program, records, scanner, diagnose, disease, robot, surgery*

### Useful constructions

*Computers are used to ...*

*A PC can also be used for ...*

*Computers can help ... make ... control ... store ... keep ... provide ... manage ... give ... perform ... measure ... test ... provide access to ...*

- B** Now write a short paragraph summarizing your discussion. Then ask one person from your group to give a summary of the group's ideas to the rest of the class.

### Examples

*In business, computers are used for financial planning, accounting and specific calculations.*

*In the office, computers are used to write letters and e-mails, and keep records of clients, suppliers and employees.*



Enter the Infotech website at [www.cambridge.org/elt/infotech](http://www.cambridge.org/elt/infotech)

Then go to the Web links section and do the activity PCs: History and Development

# Unit 2 Computer essentials

## 1 Warm-up

In pairs, label the elements of this computer system. Then read the text in Task 2 and check your answers.

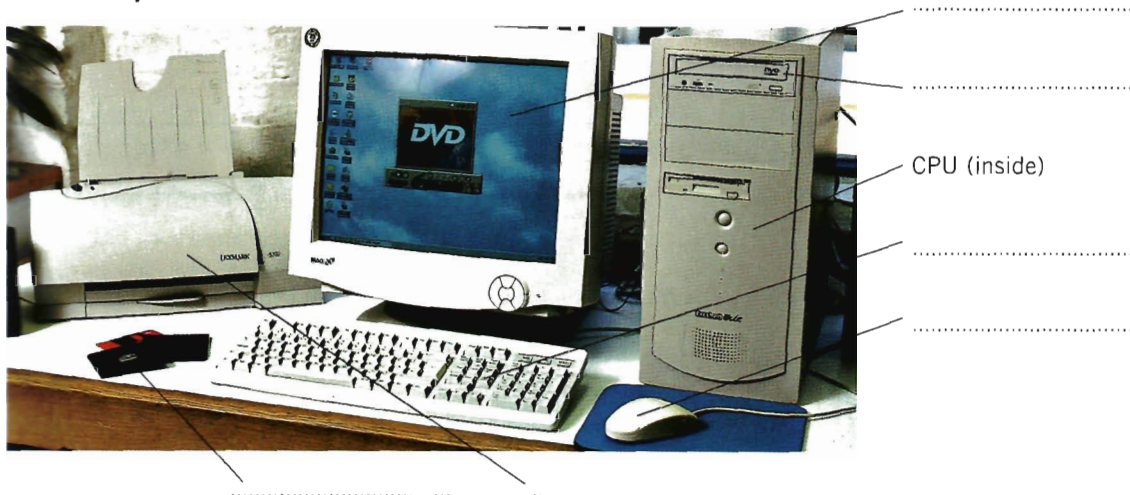

## 2 Reading

Read the text and study the diagram on page 8.

### *What is a computer?*

Computers are electronic machines which can accept data in a certain form, process the data and give the results of the processing in a specified format as information.

Three basic steps are involved in the process. *First*, data is fed into the computer's memory. *Then*, when the program is run, the computer performs a set of instructions and processes the data. *Finally*, we can see the results (the output) on the screen or in printed form (see the diagram on p. 8).

Information in the form of data and programs is known as **software**, and the electronic and mechanical parts that make up a computer system are called **hardware**. A standard computer system consists of three main

sections: the central processing unit (CPU), the main memory and the peripherals.

Perhaps the most influential component is the **central processing unit**. Its function is to execute program instructions and coordinate the activities of all the other units. In a way, it is the 'brain' of the computer. The **main memory** holds the instructions and data which are currently being processed by the CPU. The **peripherals** are the physical units attached to the computer. They include storage devices and input/output devices.

**Storage devices** (floppy, hard or optical disks) provide a permanent storage of both data and programs. **Disk drives** are used to handle one or more floppy disks. **Input devices** enable

20

25

30

35

data to go into the computer's memory. The most common input devices are the **mouse** and the **keyboard**. **Output devices** enable us to extract the finished product from the system. For example, the computer shows the output on the **monitor** or prints the results onto paper by means of a **printer**.

On the rear panel of the computer there are several ports into which we can plug a wide range of peripherals – modems, fax machines, optical drives and scanners.

These are the main physical units of a computer system, generally known as the **configuration**.

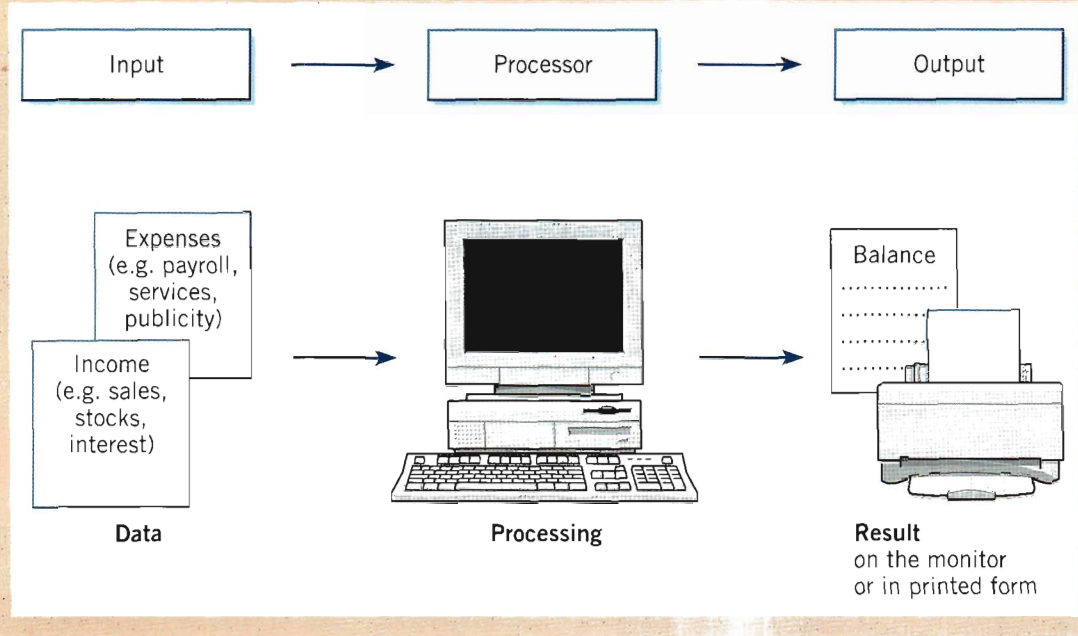

Use the information in the text and the diagram to help you match the terms in the box with the appropriate explanation or definition below.

a software b peripheral devices c monitor d floppy disk e hardware  
f input g port h output i central processing unit

- 1 The brain of the computer.
- 2 Physical parts that make up a computer system.
- 3 Programs which can be used on a particular computer system.
- 4 The information which is presented to the computer.
- 5 Results produced by a computer.
- 6 Hardware equipment attached to the CPU.
- 7 Visual display unit.
- 8 Small device used to store information. Same as 'diskette'.
- 9 Any socket or channel in a computer system into which an input/output device may be connected.

### 3 Read and guess

Read these slogans or quotations, and say what computer element they refer to.

- 1 a 'Point and click here for power.' .....
- b 'Obeys every impulse as if it were an extension of your hand.' .....
  
- 2 a 'Displays your ideas with perfect brilliance.' .....
- b 'See the difference – sharp images and a fantastic range of colours.' .....
  
- 3 a 'I love this drive. It's quiet and fast.' .....
- b 'With this it's easy to back up your data before it's too late.' .....
  
- 4 a 'Power and speed on the inside.' .....
- b 'Let your computer's brain do the work.' .....
  
- 5 a '... a big impact on the production of text and graphics.' .....
- b 'Your choice: a laser powerhouse.' .....

### 4 Get ready for listening

Before listening, answer these questions.

- 1 Have you got a computer at home, school or work? What kind is it?
- 2 How often do you use it? What do you use it for?
- 3 What are the main components and features (the configuration) of your computer system?

### 5 Listening

**A**  Listen to a short lecture given by John Griffiths, an expert on computer systems. As you listen, label the pictures below with the words in the box.

laptop

desktop PC

handheld

mainframe

minicomputer

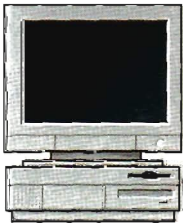

a .....

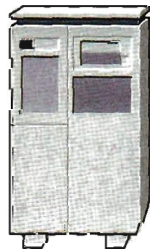

b .....



c .....

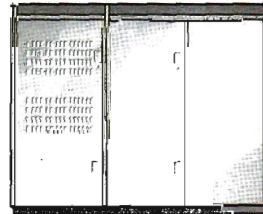

d .....



e .....

**B**  Listen again and choose the correct answer.

- 1 According to the speaker,
  - a a mainframe computer is less powerful than a minicomputer.
  - b a mainframe is more powerful than a minicomputer.
- 2 Mainframe computers are used by:
  - a executives and businessmen.
  - b large organizations that need to process enormous amounts of data.
- 3 'Multi-tasking' means:
  - a doing a number of tasks at the same time.
  - b access to a minicomputer through terminals.
- 4 The most suitable computers for home use are
  - a minicomputers.
  - b desktop PCs.
- 5 Handheld computers are
  - a small enough to fit into the palm of one hand.
  - b bigger than laptops.

## 6 Language work: Compound adjectives

Find these noun phrases in the text and explain their meaning as in the HELP box.

battery-powered systems  
hands-free operations  
waist-mounted computer  
head-mounted display  
voice-activated device

### HELP box

A compound adjective is made up of two parts and usually describes appearance. The second part is frequently a past participle.

e.g. **blue-eyed** girl = a girl who has got blue eyes  
**sugar-free** product = a product that uses no sugar

### *Wearable computers, aren't they chic?*

Can you imagine wearing a PC on your belt and getting e-mail on your eyeglasses? Wearable computers are battery-powered systems worn on the user's body - on a belt, backpack or vest and are designed for mobile or hands-free operation, often incorporating a microphone and a head-mounted display.

Some devices are waist-mounted, equipped with a wireless modem, a keypad and a small screen. Others are voice-activated, worn like a scarf and can access e-mail or voice mail.

Users of wearable technology consider themselves 'cyborgs'. This term comes from 'cybernetic organism', referring to a being that is part robot, part human.

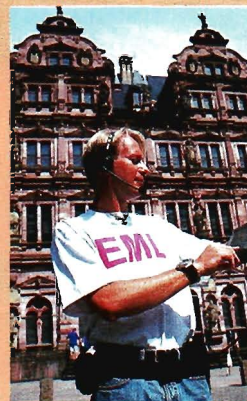

Enter the Infotech website at [www.cambridge.org/elt/infotech](http://www.cambridge.org/elt/infotech)

Then go to the Web links section and do the activity Wearable computers

# Unit 3 *Inside the system*

## 1 Warm-up

- A Read the advertisement and translate the technical specifications into your own language.



### Ulysses XT

- Pentium 4 microprocessor at 2GHz (2,000 MHz)
- 256 megabytes of RAM, upgradable to 1.5 GB
- 80 GB hard disk
- Comes with Microsoft Windows

- B Try to answer these questions. (If necessary look at the Glossary.)

- 1 What is the main function of a microprocessor?
- 2 What unit of frequency is used to measure processor speed?
- 3 What does 'RAM' stand for?

## 2 Reading

- A Read the text below and then sentences 1 to 8 on page 13. Decide if the sentences are true (T) or false (F), and rewrite the false ones to make them true.

### *What's inside a PC system?*

The nerve centre of a PC is the central processing unit or CPU. This unit is built into a single microprocessor chip – an integrated circuit – which executes program instructions and supervises the computer's overall operation. The unit consists of three main parts:

i the **control unit**, which examines the instructions in the user's program, interprets each instruction and causes the circuits and the rest of the components – disk drives, monitor, etc. – to be activated to execute the functions specified;

ii the **arithmetic logic unit** (ALU), which performs mathematical calculations (+, –, etc.) and logical operations (and, or, etc.);

iii the **registers**, which are high-speed units of memory used to store and control information. One of these registers is the program counter (PC) which keeps track of the next instruction to be performed in the main memory. Another is the instruction register (IR) which holds the instruction that is currently being executed (see Fig. 1).

One area where microprocessors differ is in the amount of data – the number of bits – they can

15

20

25

work with at a time. There are 16, 32 and 64-bit processors. The computer's internal architecture is evolving so quickly that the new 64-bit processors are able to address 4 billion times more information than a 32-bit system.

The programs and data which pass through the central processor must be loaded into the **main memory** (also called the **internal memory**) in order to be processed. Thus, when the user runs an application, the microprocessor looks for it on secondary storage devices (disks) and transfers a copy of the application into the RAM area. RAM (random access memory) is temporary, i.e. its information is lost when the computer is turned off. However, the ROM section (read only memory) is permanent and contains instructions needed by the processor.

Most of today's computers have internal **expansion slots** that allow users to install adapters or expansion boards. Popular adapters include high-resolution graphics boards, memory expansion boards, and internal modems.

The power and performance of a computer is partly determined by the speed of its microprocessor. A **clock** provides pulses at fixed intervals to measure and synchronize circuits and units. The clock speed is measured in MHz (megahertz) or GHz (gigahertz) and refers to the frequency at which pulses are emitted. For example, a CPU running at 1,600 MHz (1,600 million cycles per second) will enable the computer to handle the most demanding applications.

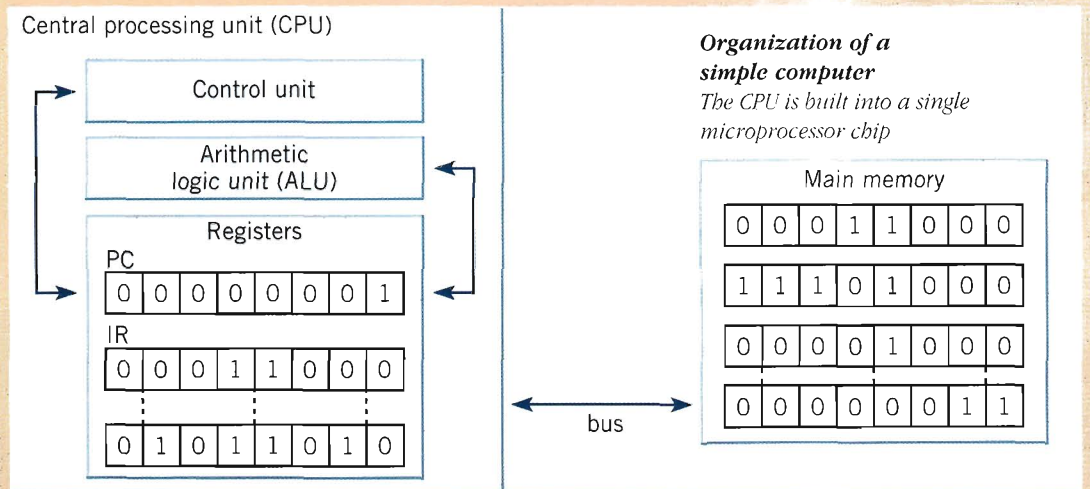
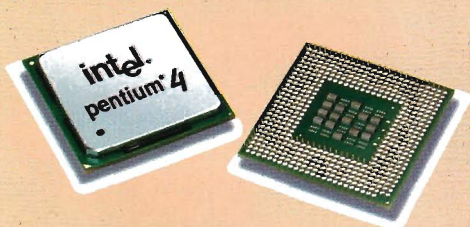

Figure 1



**Microprocessor chip**

Popular chips:

- Intel's Pentium (as shown)
- AMD's Athlon
- Apple and IBM's PowerPC
- Sun's UltraSPARC

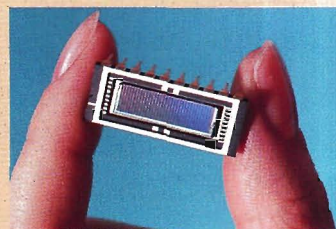

**A RAM chip**

The RAM capacity can sometimes be expanded by adding extra chips. These are usually contained in small circuit boards called single in-line memory modules (SIMMs). Modern Pentium processors also accept dual in-line memory modules (DIMMs), which allow for a wider data path.

- 1 The CPU directs and coordinates the activities taking place within the computer system.
- 2 The arithmetic logic unit performs calculations on the data.
- 3 32-bit processors can handle more information than 64-bit processors.
- 4 A chip is an electronic device composed of silicon elements containing a set of integrated circuits.
- 5 RAM, ROM and secondary storage are the components of the main memory.
- 6 Information cannot be processed by the microprocessor if it is not loaded into the main memory.
- 7 'Permanent' storage of information is provided by RAM (random access memory).
- 8 The speed of the microprocessor is measured in gigahertz or megahertz. One GHz is equivalent to one thousand MHz. One MHz is equivalent to one million cycles per second.

## Contextual reference

### B What do the words in bold print refer to?

- 1 ... **which** executes program instructions and supervises ... (line 4)
- 2 ... the instruction **that** is currently being executed. (line 23)
- 3 ... the amount of data – the number of bits – **they** can work with at a time. (line 26)
- 4 ... the microprocessor looks for **it** on ... (line 36)
- 5 ... **its** information is lost when the computer is turned off. (line 40)
- 6 ... expansion slots **that** allow users to install adapters or expansion boards. (line 45)

## 3 Language work: Relative clauses

Look at the **HELP** box and then complete the sentences below with suitable relative pronouns. Give alternative options if possible.

### HELP box

#### Relative clauses

We can define people or things with a restrictive (defining) clause.

- *The teacher **who** is responsible for the computer centre has just arrived.*  
We use the relative pronoun 'who' because it refers to a person. We could also use 'that'.
- *The microprocessor is a chip **which** processes the information provided by the software.*  
We use the relative pronoun 'which' because it refers to a thing, not a person. We could also use 'that'.
- *The computer we saw at the exhibition runs at 2.5 GHz.*  
Relative pronouns can be left out when they are not the subject of the relative clause.

- 1 That's the CPU ..... I'd like to buy.
- 2 A co-processor is an extra processor chip ..... does calculations at high speed.
- 3 The microprocessor coordinates the activities ..... take place in the computer system.

- 4 Last night I met someone ..... works for GM as a computer programmer.
- 5 A palmtop is a computer ..... is small enough to be held in the palm of one hand.
- 6 A megahertz is a unit of frequency ..... is used to measure processor speed.
- 7 Here's the DVD ..... you lent me!

## 4 Listening

**A** Label this diagram with the correct terms.

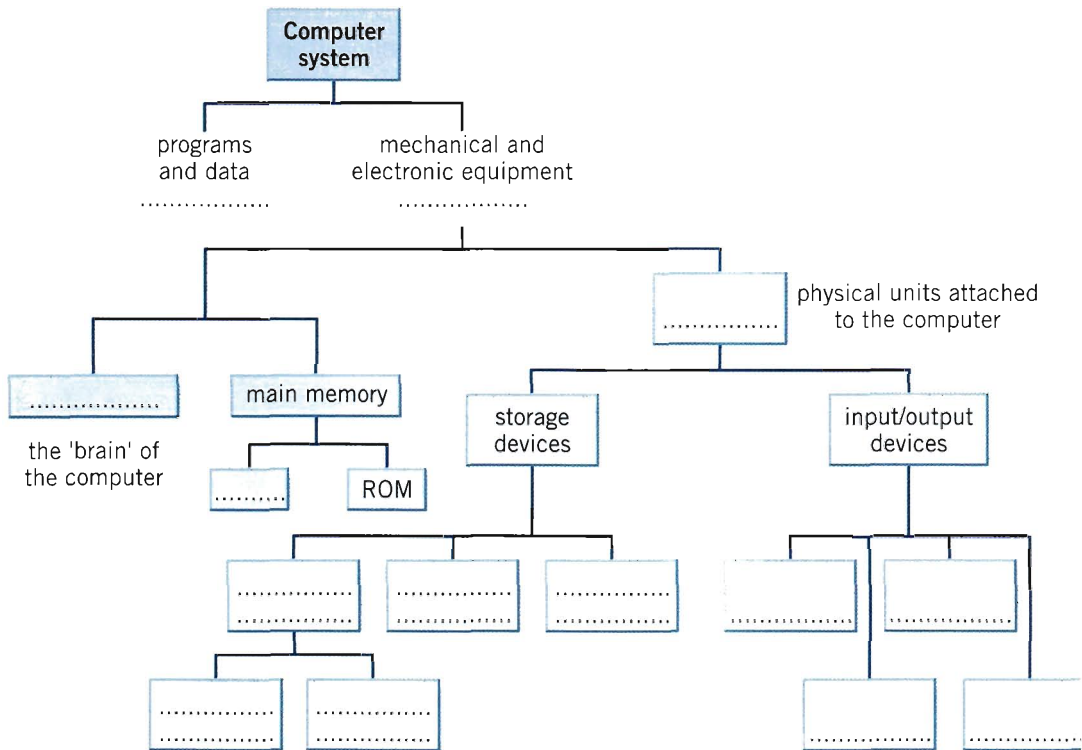

**B** Compare your answers with a partner.

**C**  Listen and check your answers.

## 5 Vocabulary quiz

In groups of three, write answers to these questions. The winners are the group that answers the most questions correctly in four minutes.

- 1 What are the main parts of the CPU?
- 2 What is RAM?
- 3 What memory section is permanent and contains instructions needed by the CPU?
- 4 What information is lost when the computer is switched off?
- 5 What is the typical unit used to measure RAM memory and storage memory?
- 6 What is the meaning of the acronym SIMM?
- 7 What is a megahertz?
- 8 What is the ALU? What does it do?
- 9 What is the abbreviation for 'binary digit'?
- 10 How can we store data and programs permanently?

## 6 Your ideal computer system

**A** Make notes about the features of the computer that you would like to have.

CPU: ..... Speed: ..... Optical disk drives: .....  
 Minimum/maximum RAM: ..... Monitor: .....  
 Hard disk: ..... Software: .....

**B** Now describe it to your partner.

### Useful expressions

*It has got ...*  
*It's very fast. It runs at ...*  
*The standard RAM memory ... and it is expandable ...*  
*The hard disk can hold ...*  
*I need a SuperVGA monitor because ...*  
*As for the Internet ...*



Enter the Infotech website at [www.cambridge.org/elt/infotech](http://www.cambridge.org/elt/infotech)

Then go to the Web links section and do the activity Acronym Finder

# Unit 4 *Bits and bytes*

## 1 Reading

**A** With a partner, try to answer these questions.

- 1 How many digits does a binary system use? What is a 'bit'?
- 2 What is the difference between binary notation and the decimal system? Give some examples.
- 3 What is a collection of eight bits called?
- 4 One kilobyte (1K) equals 1,024 bytes.

Can you work out the value of these units?      (*kilo-*: one thousand)  
1 megabyte = ..... bytes/1,024 kilobytes      (*mega-*: one million)  
1 gigabyte = ..... bytes/1,024 megabytes      (*giga-*: one thousand million)

- 5 What does the acronym 'ASCII' stand for? What is the purpose of this code?



**B** Now read the text to check your answers or to find the correct answer.

### *Units of memory*

#### **Bits – basic units of memory**

Information is processed and stored in computers as electrical signals. A computer contains thousands of electronic circuits connected by switches that can only be in one of two possible states: ON (the current is flowing through the wire) or OFF (the current is not flowing through the wire). To represent these two conditions we use **binary notation** in which 1 means ON and 0 means OFF. This is the only way a computer can 'understand' anything. Everything about computers is based upon this binary process. Each 1 or 0 is called a **binary digit** or **bit**.

#### **Bytes and characters**

1s and 0s are grouped into eight-digit codes that typically represent characters (letters, numbers and symbols). Eight bits together are called a **byte**. Thus, each character in a keyboard has its own arrangement of eight bits. For example, 01000001 for the letter A, 01000010 for B and 01000011 for C.

#### **The ASCII code**

The majority of computers use a standard system for the binary representation of

characters. This is the American Standard Code for Information Interchange, known popularly as 'ASCII' (pronounced 'ask-key'). There are 256 different ways of combining 0 and 1 bits in a byte. So they can give us 256 different signals. However, the ASCII code only uses 128 bytes to represent characters. The rest of the bytes are used for other purposes.

The first 32 codes are reserved for characters such as the Return key, Tab, Escape, etc. Each letter of the alphabet, and many symbols (such as punctuation marks), as well as the ten numbers, have ASCII representations. What makes this system powerful is that these codes are standard.

#### **Kilobytes, megabytes and gigabytes**

In order to avoid astronomical figures and sums in the calculation of bytes, we use units such as kilobytes, megabytes and gigabytes. One kilobyte is 1,024 bytes ( $2^{10}$ ) and it is represented as KB, or more informally as K. One megabyte is equivalent to 1,024 KB, and one gigabyte is 1,024 MB.

We use these units (KB, MB, GB) to describe the RAM memory, the storage capacity of disks and the size of any application or document.

**C** Look at the illustrations and the captions below. Then fill in the blanks with the correct unit of memory.

English

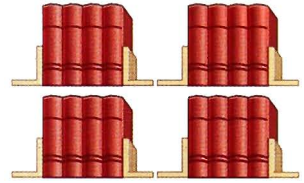

- 1 One ..... represents one character.
- 2 One ..... represents 1,024 characters (about a small page of text).
- 3 One ..... represents 1,000,000 characters (about the text of this book).
- 4 One ..... represents 1,000,000,000 characters (about 1,000 books in a library).

## 2 Word building

**A** The table gives some prefixes commonly used in computer science. Knowing the meaning of these prefixes will help you understand new words.

Prefix	Meaning	Examples
deci-	ten	<i>decimal, decimalize, decibel</i>
hexadeci-	sixteen	<i>hexadecimal</i>
kilo-	one thousand (1,000) (1,024 in binary: $2^{10}$ )	<i>kilocycle, kilogram(me), kilowatt</i>
mega-	large; one million	<i>megabertz, megalith, megaton</i>
giga-	very large; one thousand million	<i>gigantic, gigabyte, gigabertz</i>
mini-	small	<i>minibus, minimum, minimize</i>
micro-	very small	<i>microfilm, microphone, microwave</i>
bi-	two	<i>bidirectional, bidimensional, binary</i>
tri-	three	<i>tripartite, tricycle, trilingual</i>
multi-	many	<i>multi-racial, multi-user, multitasking</i>
mono-	one	<i>monologue, monosyllable, monolingual</i>

**B** Explain these expressions, taking into account the prefixes and root word.

**Example**

the binary system

*The binary system is a notation which uses two digits, 0 and 1.*

- 1 a minicomputer
- 2 a microcomputer
- 3 the decimal system
- 4 the hexadecimal system
- 5 a multi-user configuration
- 6 a bidimensional chessboard
- 7 a tricycle
- 8 a monochrome computer
- 9 a CPU with 256 MB of RAM
- 10 a document of 3 kilobytes

## 3 Bits for pictures

### A Read the questions and text and study the diagrams.

#### Did you know that ...

- 1 bits can also be used to code pictures?
- 2 the information displayed on the computer screen corresponds, dot by dot, with bits held in the main memory?
- 3 on colour systems, if you have 8 bits per primary colour, the palette of your computer can obtain 16.7 million colours?

Each tiny dot on the screen of a computer is called a picture element or **pixel**. Images and text are formed by combining a large number of pixels.

In a bit-mapped display, the dots displayed on the screen correspond, pixel by pixel, with bits in the main memory of the computer. The bits are held in an area of the memory called the 'refresh buffer' and are stored in groups that represent the horizontal and vertical position of the pixels on the screen and whether the pixels are on or off.

On monochrome systems, one bit in this 'map' represents one pixel on the screen and can be either 'on' or 'off' (black or white).

0	0	0	0	0	0	0	0	0	0
0	1	1	1	1	1	1	1	0	0
0	1	0	0	0	0	0	0	1	0
0	1	0	0	0	0	0	0	1	0
0	1	0	0	0	0	0	0	1	0
0	1	0	0	0	0	0	0	1	0
0	1	0	0	0	0	0	0	1	0
0	1	0	0	0	0	0	0	1	0
0	1	1	1	1	1	1	1	1	0
0	0	0	0	0	0	0	0	0	0

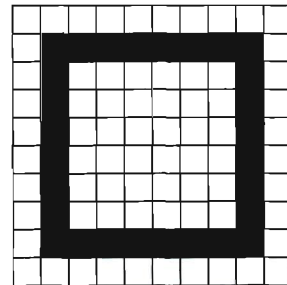

*Refresh buffer (memory)*

*Display*

On colour systems, each pixel is a certain combination of the three primary colours: red, green and blue. The total number of colours which can be shown on the screen is called the colour palette. The size of this palette depends on the graphics adaptor, a separate video card that converts the bits into visual signals. A graphics adaptor with 1 bit per primary colour can generate up to 8, or  $2^3$ , colours, as you can see from the table on page 19. A graphics adaptor with 8 bits per primary colour can generate 16.7 million or  $(2^3)^8$  colours.

<i>Colour</i>	<i>Red</i>	<i>Green</i>	<i>Blue</i>
black	0	0	0
blue	0	0	1
green	0	1	0
cyan	0	1	1
red	1	0	0
magenta	1	0	1
yellow	1	1	0
white	1	1	1

*One bit per primary colour*

**B** Using the information in the passage and the illustrations, match the terms in the box with the appropriate explanation or definition.

a pixel    b bit    c bit-mapped display  
d primary colours    e palette

- The menu of colours available on a graphics system; its size depends on the hardware.
- Red, green and blue (RGB) in computers.
- The smallest element of a display surface.
- A display on the screen which corresponds, pixel by pixel, with bits stored in memory cells.
- The acronym for 'binary digit'; one of the digits (0 and 1) used in binary notation.

**C** Translate the last paragraph (starting from 'On colour systems, ...') into your language.

Do you understand the calculations made to obtain a palette of 16.7 million colours? (If you don't, ask a partner to explain them to you.)



Enter the Infotech website at [www.cambridge.org/elt/infotech](http://www.cambridge.org/elt/infotech)

Then go to the Web links section and do the activity Online Computer dictionaries

# Unit 5 *Buying a computer*

## 1 Before you listen

Name eight different items you can buy in a computer shop.



## 2 Listening

**A** You are going to hear two people making enquiries in a Macintosh computer shop. The shop assistant is telling them about the two models below. Listen and fill in the missing information.



**iMac**  
 Processor speed 1 GHz  
 RAM standard .....  
 Hard disk capacity .....  
 Price .....  
 DVD and Mac .....  
 OS included? .....

**iBook**  
 Processor speed .....  
 RAM standard .....  
 Hard disk capacity .....  
 Price £1,207  
 DVD and Mac .....  
 OS included? .....



**B** Now listen again and fill in the gaps below.

- Assistant: Do you need any help?  
 Paul: Um yes, we're looking for a personal computer. Have you got any fairly basic ones?  
 Assistant: Yes, sure. If you'd like to come over here ...  
 Paul: What different (1) ..... are there?  
 Assistant: At the moment we've got these two models: The iMac, which is a desktop computer with a (2) ..... operating at 1 gigahertz, and the portable iBook, which has a processor (3) ..... at 700 megahertz.

- Sue: So the iMac is the (4) ..... one. And which one has the most memory? I mean – which has the most RAM?
- Assistant: Well, the iMac has 256 megabytes of (5) ....., which can be (6) ..... up to 1 gigabyte, and the iBook has 128 megabytes which can be expanded up to (7) ..... It all depends on your needs. The iMac is suitable for home users and small offices. The iBook is ideal for students and for people who travel.

### 3 Role play

**Work with a partner. One of you wants to buy a computer, the other is the sales assistant. Ask and answer questions, using the information and instructions below to help you.**

<i>Products available</i>	<i>Processor Speed</i>	<i>Minimum/Maximum RAM</i>	<i>Hard disk</i>	<i>Disk drives</i>	<i>Monitor</i>	<i>Price</i>
Explora 700 Net PC	Mips R4700 900 MHz	128 MB expandable to 512	20 GB	Optional 3.5" drive	Super VGA compatible	£799
Toshiba portable	Pentium 4 1.5 Ghz	256 MB expandable to 512	40 GB	3.5" drive DVD/ CD-RW	colour LCD	£2,309
IBM	Pentium 4 1.8 GHz	256 MB expandable to 512	70 GB	DVD CD-RW	XGA	£2,149
Dell	AMD Athlon 1.6 GHz	512 Mb expandable to 2 GB	80 GB	3.5" drive DVD/ CD-RW	SuperVGA	£2,700
Dell	Pentium 4 2 GHz	256 MB expandable to 1 GB	60 GB	DVD/ CD-RW	XGA	£2,710

#### Shop assistant

Greet the customer and offer help.

Show the customer some models.

Describe the speed in megahertz and the main memory.

Give explanations (GB storage capacity, etc.).

Give the required information.

Give the price and explain different ways of paying.

#### Customer

Ask to see some computers.

Ask for details: processor, RAM, etc.

Ask about the hard disk.

Ask about the monitor and other features.

Ask the price.

Decide to buy one/to think about it.

Thank the shop assistant and leave the shop.

## 4 Read and talk

**A** Read the descriptions of the four people and the four computers below and on page 23. With a partner, choose the most suitable computer for each person. Give reasons for your choices.

- 1 Daniel is a history student. He needs a computer to write essays, assignments and letters. He likes surfing the web.
- 2 Sarah is the manager of an advertising company. She needs a powerful system which will work with optical disks and multimedia applications, integrating text and pictures with animation and voice annotations. Digitized images and sound occupy a lot of disk space.
- 3 Andy is a CAD engineer. His job involves computer-aided design, simulations and three-dimensional modelling. These applications require a lot of memory and a large drive.
- 4 Tanya is a sales representative. She needs a lightweight machine with which she can process orders and communicate with head office while she is on the road.

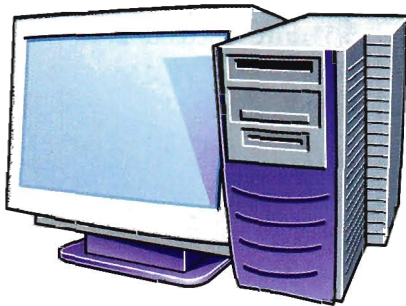

### Sun workstation

- 900 MHz UltraSPARC processor
- Multiprocessor machine (expandable to two CPUs)
- 8-GB RAM capacity
- 72-GB internal hard drive
- DVD-ROM
- Supports several graphics formats
- Lets you attach any peripherals and link up to any network
- Allows you to handle your toughest technical, scientific, and business-critical applications
- Requires Solaris Operating system
- £5,049



### Compaq Presario PC

- 500 MHz Pentium III processor
- 128 MB of RAM expandable to 384 MB
- 19 GB Quantum Bigfoot hard disk
- Built-in Zip drive
- DVD-ROM drive
- JBC speakers, Dolby Digital Surround Sound
- Integrated digital modem
- Windows
- £700



### Compaq Evo Notebook N200

- Intel's 700 MHz Low Voltage Mobile Pentium III processor
- 192 MB RAM
- 20 GB hard drive
- Optional 1.44 MB diskette drive
- CD-RW, DVD-ROM
- 10.4" colour TFT display, with 1024 x 768 pixel resolution (16 million colours)
- Integrated keyboard, touch pad as pointing device
- Integrated mini-PCI modem
- Lithium-ion battery, with enough battery life for a workday
- Weight: 2.5 pounds
- Dimensions: 25.15 x 19.8 x 2.11 cm
- Windows comes pre-installed
- £1,190



### Power Mac G4

- PowerPC processor at 933 MHz
- 256 MB of RAM expandable to 1.5 GB
- 2 MB of in-line cache on the processor card
- Graphics card with 64 MB of SDRAM
- 80 GB hard disk
- DVD-R and CD-RW Superdrive
- Comes with Apple monitor, sound board, built-in microphone, and stereo speakers
- Mac OS with QuickTime (an extension that lets you play video and animation on the computer), digital video editing and DVD authoring software
- £ 4,149

**B** Look back at the notes you made for Task 6 in Unit 3 (page 15) about your ideal computer system. What did you want?

Read the descriptions of these computers again and choose the one that is closest to your ideal. Explain the reason for your choice.

## 5 Vocabulary tree

Designing vocabulary trees or networks can help you build up your own mental 'maps' of vocabulary areas. Look at the list of terms in the box and put each one in an appropriate place on the vocabulary tree below. The first one has been done for you.

*processor*  
*megahertz*  
*RAM*  
*DVD*  
*mouse*  
*megabyte*

*kilobyte*  
*SIMMs*  
*computer brain*  
*clock speed*  
*gigahertz*  
*floppy disk*

*expandable memory*  
*hard disk*  
*byte*  
*keyboard*  
*CD-ROM*  
*registers*

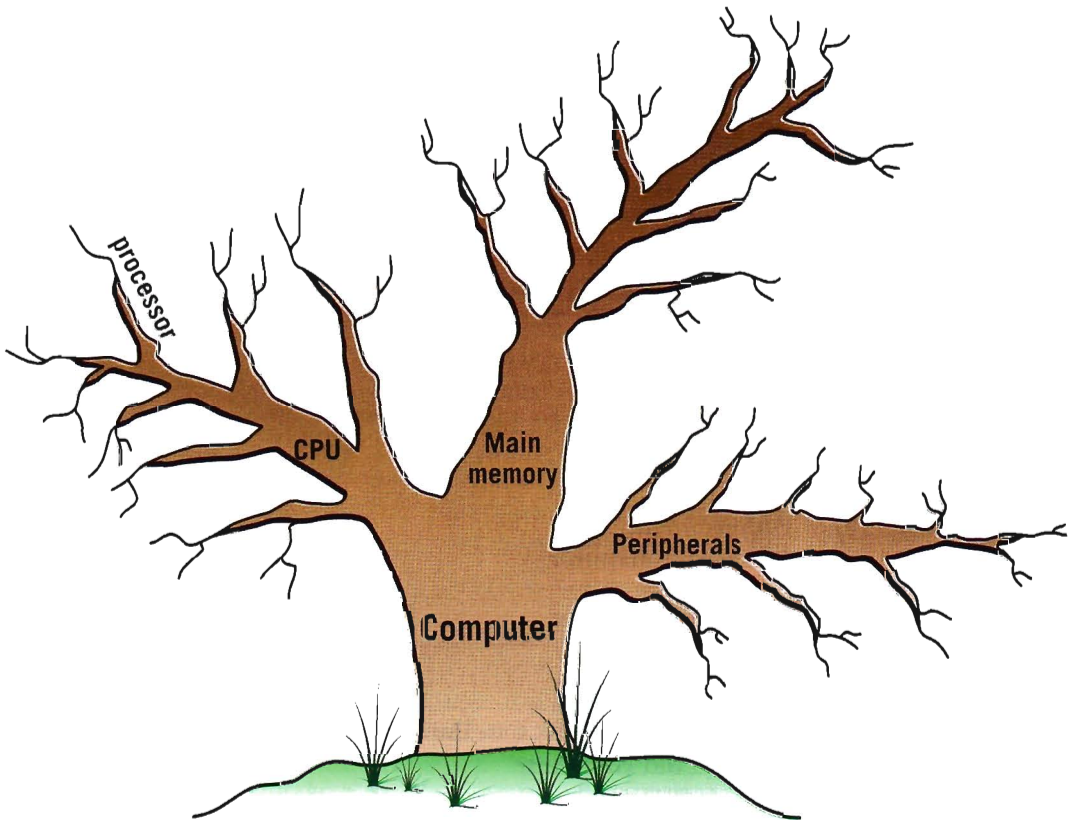

## 6 Writing

A friend has written to you asking you to recommend a computer that suits their needs. Write a letter in reply, describing its technical features and saying why you recommend it.

# Input/output devices

Unit	page
6 <i>Type, click and talk!</i>	26
7 <i>Capture your favourite image</i>	31
8 <i>Viewing the output</i>	35
9 <i>Choosing a printer</i>	39
10 <i>I/O devices for the disabled</i>	44

## Learning objectives

**In this section you will learn how to:**

- describe input and output devices
- identify important keys on a keyboard and explain their functions
- distinguish between facts and opinions in advertisements about peripherals (e.g. scanners)
- understand technical specifications given about digital cameras and monitors
- use different grammatical forms to give instructions, advice or warnings
- compare different types of printers, and choose one for yourself
- understand what sort of input/output devices are used by disabled people.

# Unit 6 *Type, click and talk!*

## 1 Interacting with your computer

**Input devices** are the pieces of hardware which allow us to enter information into the computer. The most common are the keyboard and the mouse. We can also interact with a computer by using one of these: a lightpen, a scanner, a trackball, a graphics tablet, a joystick or a voice recognition device.

Look at the illustrations and see if you can name them.

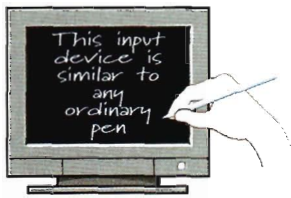

1 .....



2 .....

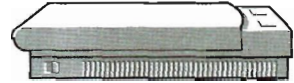

3 .....



4 .....



5 .....

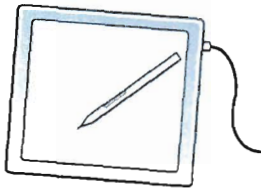

6 .....



7 .....

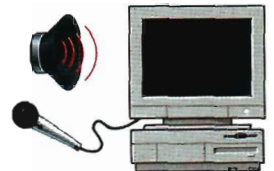

8 .....

## 2 Listening

A  Listen to these descriptions of three input devices. What are they?

1 ..... 2 ..... 3 .....

B Check your answers with a partner.

### 3 Language work

Look at the HELP box and then use the notes below to write a similar description of a joystick.

#### HELP box

##### Describing function

In Task 2, the mouse was described like this:

*This is a device for controlling the cursor and selecting items on the screen.*

*for controlling* describes what the mouse does (*for + -ing*)

There are several ways of describing function:

- *for + -ing (for controlling)*
- *relative pronoun + verb (which controls)*
- *relative pronoun + is used + to + infinitive (which/that is used to control)*
- *used + to + infinitive (used to control)*

Input device

Use: play games

The user takes hold of a lever to control/move the cursor around the screen.

### 4 Speaking

Work in pairs. Student A: turn to page 143 and Student B: turn to page 147.

### 5 About the keyboard

**A** Look at the picture of a PC-compatible keyboard and identify these groups of keys.

- 1 **Alphanumeric keys:** arranged in the same order as a typewriter.
- 2 **Function keys:** used by various programs to instruct the PC to perform specific tasks, such as Save, Copy, Cut, Paste, Help, etc.
- 3 **Numeric keypad:** set of numeric or editing keys. The Num Lock key is used to switch from numbers to editing functions.
- 4 **Editing keys:** cursor and other keys usually used within word processors to page up and down in a long document or to edit text (using Insert or Delete keys).
- 5 **Special keys:** used to issue commands or to produce alternative characters in *key combinations, for example, the Alt key.*

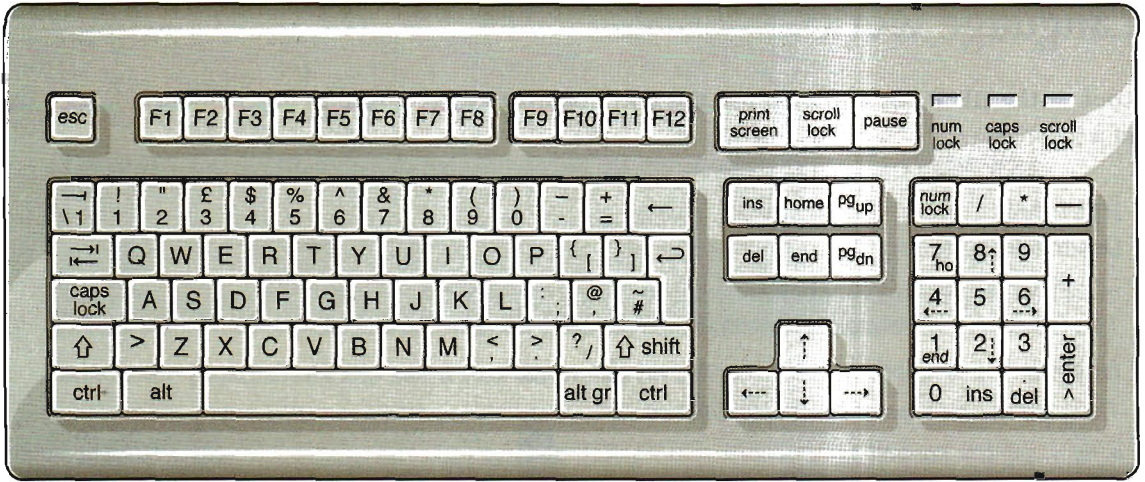

A PC-compatible keyboard

**B Match these descriptions with the names of keys on the right. Then find them on the keyboard.**

- 1 A long key at the bottom of the keyboard. Each time it is pressed, it produces a blank space. (= .....
- 2 It moves the cursor to the beginning of a new line. It is also used to confirm commands. (= .....
- 3 It stops a program without losing the information from the main memory. Sometimes its use depends on the applications. (= .....
- 4 It works in combination with other keys to produce special characters or specific actions. (= .....
- 5 It removes the character on the left of the cursor or any selected text. (= .....
- 6 It produces UPPER-CASE characters (or the upper-case character of the key). (= .....
- 7 It produces upper-case letters, but it does not affect numbers and symbols. (= .....
- 8 It moves the cursor horizontally to the right for a fixed number of spaces (in tabulations and data fields). (= .....
- 9 They are used to move the cursor, as an alternative to the mouse. (= .....

arrow keys

return

caps lock

shift

tab

escape

space bar

backspace

alt

## 6 Mouse actions

Read this passage about a computer mouse. Fill in the gaps with verbs from the list.

click    double-click    drag    grab    select    move    control

A mouse allows you to (1) ..... the cursor and move around the screen very quickly. Making the same movements with the arrow keys on the keyboard would take much longer. As you (2) ..... the mouse on your desk, the pointer on the screen moves in the same direction. The pointer usually looks like an I-bar, an arrow or a pointing hand, depending on what you are doing.

A mouse has one or more buttons to communicate with the computer. For example, if you want to place the insertion point or choose a menu option, you just (3) ..... (press and release) on the mouse button, and the option is chosen.

The mouse is used to (4) ..... text and items on the screen. You can highlight text to be deleted, or you can select an item from a check-box or questionnaire.

The mouse is widely used in graphics and design. When you want to move an image, you position the pointer on the object you want to move, press the mouse button, and (5) ..... the image to a new location on the screen. Similarly, the mouse is used to change the shape of a graphic object. For example, if you want to convert a square into a rectangle, you (6) ..... one corner of the square and stretch it into a rectangle.

The mouse is also used to start a program or open a document: you put the pointer on the file name and (7) ..... on the name – that is, you rapidly press and release the mouse button twice.

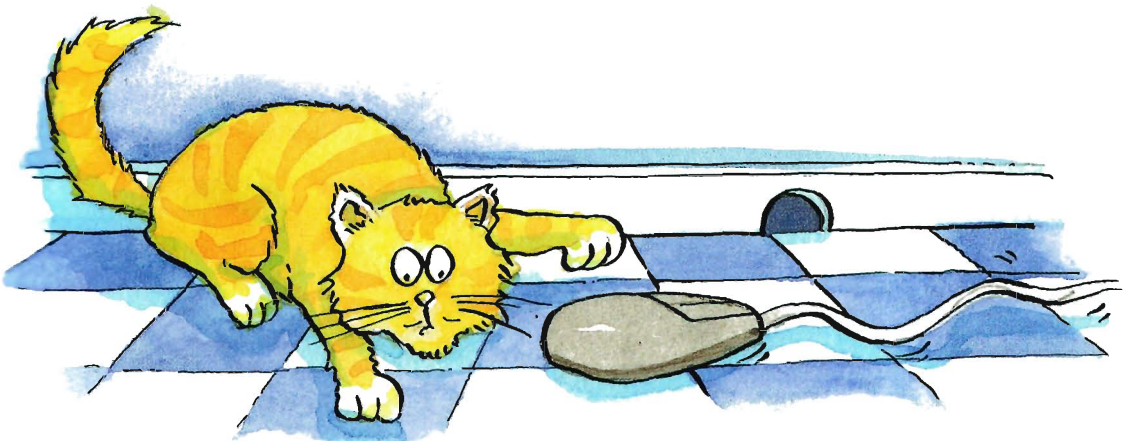

## 7 Listening

A  Listen to an interview with Anne, an expert in voice-input technologies. Tick (✓) the features that she mentions.

- need a good sound card and a microphone
- take dictation with accuracy
- create and compile a computer program
- surf the Web by speaking
- execute programs and navigate around menus by voice commands
- design graphics

B  Listen again and fill in the gaps in these sentences. Use the correct modal verb from the list.

can (ability)      must (necessity)      should (advice)  
could (possibility)      will (prediction)

- 1 If you intend to do a lot of dictation, you ..... get a high-quality headset microphone.
- 2 You ..... dictate text directly onto your word processor or e-mail program.
- 3 With many voice-recognition programs, the user ..... first train the software to recognise individual pronunciations.
- 4 Speech-recognition software ..... help children with special educational needs.
- 5 In a few years' time, a lot of people ..... use their voices to interact with computers.



Enter the Infotech website at [www.cambridge.org/elt/infotech](http://www.cambridge.org/elt/infotech)

Then go to the Web links section and do the activity Talk to your computer

# Unit 7 *Capture your favourite image*

## 1 The eyes of your computer

You can capture your favourite pictures using three different input devices: a scanner, a digital camera, or a camcorder.

Use the information below to answer these questions.

- 1 Which device is used to input text and graphic images from a printed page?
- 2 How does a colour scanner work?
- 3 Do digital cameras use film? How do they store photographs?
- 4 Which device would you use to take digital video?
- 5 What kind of software is used to manipulate video clips on the computer?
- 6 What do you think are the benefits of using scanners and cameras at home and in business?

### *What does a scanner do?*

A scanner 'sees' images and converts the printed text or pictures into electronic codes that can be understood by the computer.

With a flatbed scanner, the paper with the image is placed face down on a glass screen similar to a photocopier. Beneath the glass are the lighting and measurement devices. Once the scanner is activated, it reads the image as a series of dots and then generates the digitized image that is sent to the computer and stored as a file.

A colour scanner operates by using three rotating lamps, each of which has a different coloured filter: red, green and blue. The resulting three separate images are combined into one by appropriate software.

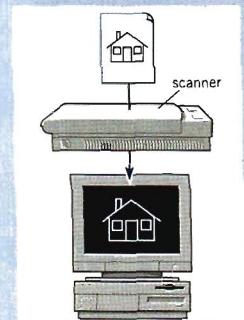

### *What does a digital camera do?*

A digital camera takes photos electronically and converts them into digital data (binary codes made up of 1s and 0s). It doesn't use the film found in a normal camera; instead it has a special light-sensitive silicon chip. Photographs are stored in the camera's memory before being sent to the computer. Some cameras can be also connected to a printer or a TV set, to make viewing images easier.



### *What does a camcorder do?*

A camcorder, or digital video camera, records moving pictures and converts them into digital data that can be stored and edited by a computer with special video editing software.

Digital video cameras are used by home users to create their own movies, or by professionals in computer art and video conferencing.

They are also used to send live video images via the Internet. Then they are called Web cameras or webcams.



## 2 Listening

 Listen to the conversation between Vicky Cameron, an Information Technology (IT) lecturer, and one of her students, and complete these notes.

- 1 The technology used in scanners is similar to that used in .....
- 2 A laser beam reads the image in .....
- 3 The image is then .....
- 4 Text is scanned with .....
- 5 Flatbed scanners can scan .....
- 6 Slide scanners are used to scan .....
- 7 Hand-held scanners are used for capturing .....

## 3 Facts and opinions

**A** Read the advertisements below and underline what you think are facts and circle the opinions. Then write them in the table on page 33.

*Facts* are 'real' objective information.

*Opinions* usually include emotive words, positive/negative phrases and subjective (persuasive) statements.

### HELP box

- **dpi:** dots per inch
- **JPEG:** – a standard format in image compression.

1

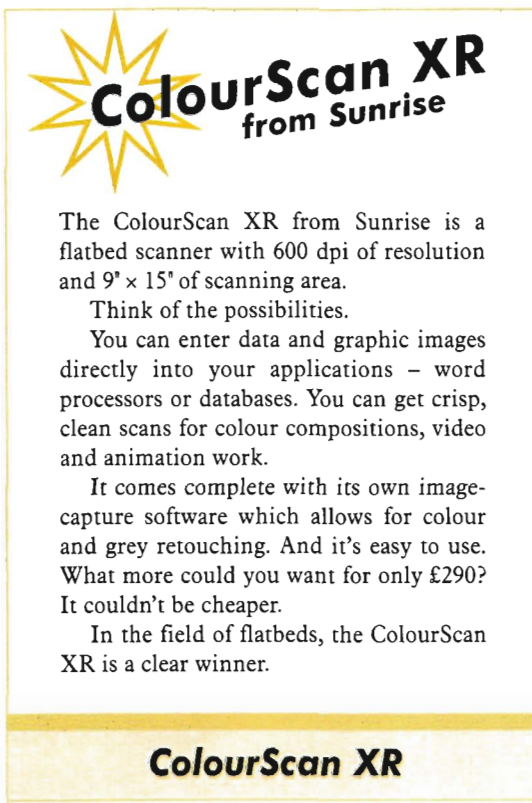

**ColourScan XR**  
from Sunrise

The ColourScan XR from Sunrise is a flatbed scanner with 600 dpi of resolution and 9" × 15" of scanning area.

Think of the possibilities.

You can enter data and graphic images directly into your applications – word processors or databases. You can get crisp, clean scans for colour compositions, video and animation work.

It comes complete with its own image-capture software which allows for colour and grey retouching. And it's easy to use. What more could you want for only £290? It couldn't be cheaper.

In the field of flatbeds, the ColourScan XR is a clear winner.

**ColourScan XR**

2



**ScanPress 800**

The ScanPress 800 is a self-calibrating, flatbed scanner with 800 dpi of resolution. You can scan from black and white to 24-bit colour. The package includes a hardware accelerator for JPEG compression and decompression. JPEG technology saves disk space by compressing images up to 50 to 1.

In creating ScanPress 800, the manufacturers have chosen the highest technology to give you the best scans with the least effort. It produces images with high colour definition and sharpness. And it comes with OCR software and Adobe Photoshop, so you can manipulate all the images you capture.

This is a fantastic machine you will love working with. And at only £510 it is an excellent investment.

	<i>ColourScan XR</i>	<i>ScanPress 800</i>
<b>Facts</b>	Flatbed scanner 600 dpi of resolution	Self-calibrating, flatbed scanner
<b>Opinions</b>	You can get crisp, clean scans	The highest technology

**B** In small groups, compare your answers and decide:

- 1 which text has got more persuasive language?
- 2 which text is more factual or objective?

## 4 Language work: Comparatives and superlatives

Apart from catchy slogans and other persuasive techniques, advertisements often use the comparatives and superlatives of adjectives and adverbs. Read the following examples from advertisements. What can you say from these examples about how comparatives and superlatives are formed?

- 1 ... only ten times faster.
- 2 It couldn't be cheaper.
- 3 The manufacturers have chosen the highest technology ...
- 4 The cleverest personal scanner ...
- 5 The most revolutionary computer peripheral ...
- 6 The best scans with the least effort ...
- 7 Flatbed scanners are more accurate than ...
- 8 Now you can edit your documents more easily than ever, and they'll look better than ever too with ...

## 5 Word building

The class of a word can often be changed by adding a suffix. For example, if *-er* is added to the verb *scan* (and the 'n' is doubled) we get the noun *scanner*.

Common adjectival suffixes are: *-ing*, *-y*, *-able*, *-ible*, *-ive*, *-al*, *-ed*, *-ful*

Common noun suffixes are: *-er*, *-or*, *-ion*, *-tion*, *-ation*, *-ment*, *-ness*, *-ity*, *-ant*, *-logy*

Put the words in the box into the correct column below.

computer self-calibrating easy resolution sharpness information  
printed personal capable compression technology calculator  
useful assistant expensive possibility reducible investment

Adjectives

Nouns

.....  
.....  
.....  
.....  
.....  
.....  
.....  
.....  
.....

.....  
.....  
.....  
.....  
.....  
.....  
.....  
.....  
.....

## 6 Advertisement: A digital camera

Some words have been left out of this persuasive advertisement. Read it and complete it with words from the box.

vivid easy-to-use faster fashionable wide shots

If you want great pictures from an (1) ..... digital camera, you want the Kodak DC215. Now you can capture life's memories in style with this sleek and (2) ..... digital camera.

The camera's 2X (29 mm–58 mm) optical zoom lens lets you get close up and personal without sacrificing image detail or quality while the (3) ..... angle lens design helps you capture more in each shot.

With one million (1152 × 864) pixels, you'll have enough detail to generate crisp, (4) ..... realistic photos up to 5" × 7".

The 1.8" colour LCD lets you preview and review your pictures so you get only the (5) ..... you want, and lets you delete those you don't.

With the included USB COMPACTFLASH Card Reader, you can download pictures up to ten times (6) ..... than with serial connections for faster image sharing.

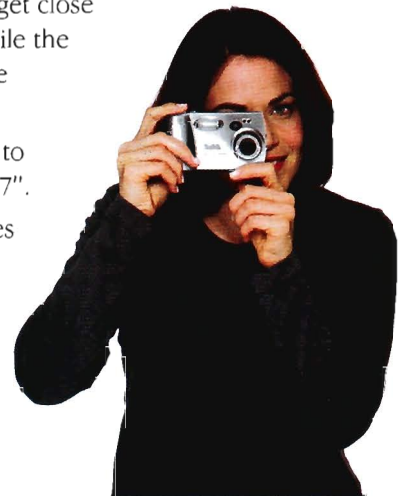

# Unit 8 *Viewing the output*

## 1 Warm-up

After the information has been processed by the CPU, we can see the results on the screen. This is also called a monitor or visual display unit (VDU).

**Describe the monitor of your computer to another student. Use these questions to help you.**

- Is it a monochrome or a colour monitor?
- What size is the screen?
- Does it have a cathode ray tube or a flat LCD screen?
- How can you change the picture using the controls?
- Does it produce a high quality image?



## 2 Reading

**A Read the text and try to guess the meaning of any new words in the box below. Refer to the Glossary if necessary.**

dot pixel display resolution cathode ray tube electron beam  
scan (verb) hertz refresh rate flicker bit-mapped visualize

### *The monitor*

The characters and pictures that we see on the screen are made up of dots, also called picture elements (pixels). The total number of pixels in which the display is divided both horizontally and vertically is known as the **resolution**. If

the number of pixels is very large, we obtain a high resolution display and therefore a sharp image. If the number of pixels is small, a low resolution is produced.

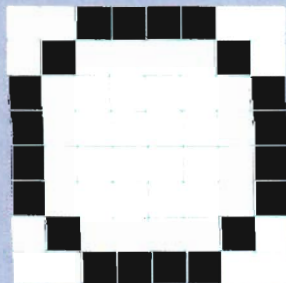

*Low resolution display*

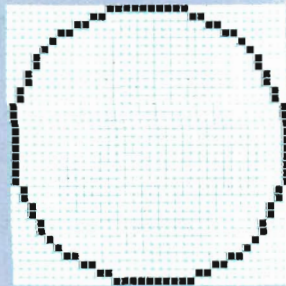

*High resolution display*

10 Typical resolutions are  $640 \times 480$  or  $1,024 \times 768$  pixels. The diagrams on page 35 show how pixel density affects the image: a larger number of pixels gives a much clearer image.

15 The **cathode ray tube** of the monitor is very similar to that of a TV set. Inside the tube there is an electron beam which scans the screen and turns on or off the pixels that make up the image. The beam begins in the top left corner, and scans the screen from left to right in a continuous sequence, similar to the movement of our eyes when we read, but much faster.  
20 This sequence is repeated 50, 70 or 85 times per second, depending on the system. If the rate of this repetition is low, we can perceive a flickering, unsteady screen, which can cause eye fatigue. However, a fast-moving 75 Hz 'refresh rate' eliminates this annoying flicker.

25 What we see on the screen is created and stored in an area of RAM, so that there is a memory cell allocated to each pixel. This type of display is called **bit-mapped**. On monochrome monitors, bits 0 are visualized as white dots, and bits 1 as black dots.

35 On colour displays, there are three electron guns at the back of the monitor's tube. Each gun shoots out a beam of electrons for each of the primary colours: red, green and blue. These electrons strike the inside of the screen which is coated with substances called phosphors that glow when struck by electrons.  
40

Three different phosphor materials are used – one each for red, green and blue. To create different colours, the intensity of each of the three electron beams is varied.

The monitor is controlled by a separate circuit board, known as the display adaptor, which plugs into the motherboard of the computer. Different boards drive different types of displays. For example, the **VGA** (video graphics array) card has become a standard for colour monitors.

Now flat-screen monitors are fashionable. They are inherently flat, and therefore require less space. In addition, they give crisp, clear images and eliminate screen flicker.

Portable computers use a flat **liquid-crystal display** (LCD) instead of a picture tube. An LCD uses a grid of crystals and polarizing filters to show the image. The crystals block the light in different amounts to generate the dots in the image.

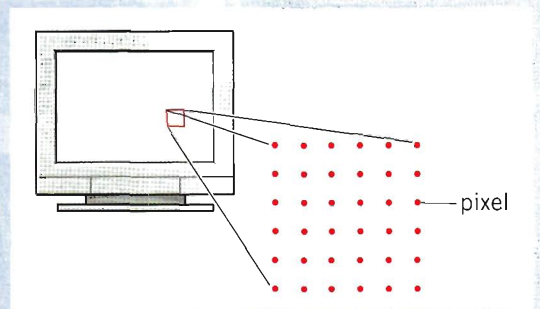

*Each dot on the screen is a pixel*

## B Read the text again and answer these questions.

- 1 According to the writer, what is the importance of 'pixel resolution'?
- 2 Which unit of frequency is used to measure the refresh rate of a monitor?
- 3 In the writer's opinion, why can a low refresh rate produce eye fatigue?
- 4 What substance is hit by electrons in a monitor?
- 5 What is the standard display system for many PCs?
- 6 What does 'LCD' stand for? What type of computers use LCD displays?

### 3 Writing

**A** Tables often include abbreviations and technical words that are not easy to understand. Look at this table and the explanation of Monitor A's specifications.

	Type	Size	Pixel res.	Visual display	Refresh rate	Tilt-and-swivel	Other features
<b>Monitor A</b> Compaq TFT 8020	Flat-panel LCD	18.1"	1024 × 768	16.7 million colours	75 Hz flicker-free	✓	energy saver mode
<b>Monitor B</b> Paintview	CRT monitor	19"	1280 × 1024	16.7 million colours	85 Hz flicker-free	✓	anti-glare filter

The specifications of Superview (Monitor A) may be explained like this:

- 1 This is a flat-panel Liquid Crystal Display.
- 2 The screen size is 18.1 inches (diagonal viewable image size).
- 3 You get a resolution of 1024 by 768 pixels.
- 4 It offers support for 16.7 million saturated colours.
- 5 This digital display has a 75 hertz refresh rate. It never flickers (the images are bright, sharp, and distortion-free).
- 6 You can change the orientation of the display, adjusting your viewing angle back and forth.
- 7 It has a built-in power feature that saves a lot of energy consumption.

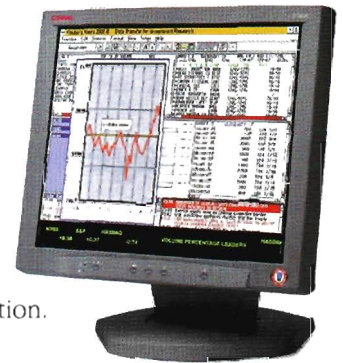

**B** Use the example above to help you describe Monitor B.

### 4 Listening

 Tony Clark, a lecturer in computer ergonomics, is talking to some students about health and safety in a computer classroom. Listen and complete the sentences below. Then decide where they should go in the pictures on page 38. Write the number of each in the correct place.

- 1 You should get a good chair, one that .....
- 2 Position the keyboard .....
- 3 Position the monitor ..... eye level, or just .....
- 4 A tilt-and-swivel display lets you .....
- 5 You should stay an arm's length away from .....
- 6 If you work in a room with a lot of computers, sit .....

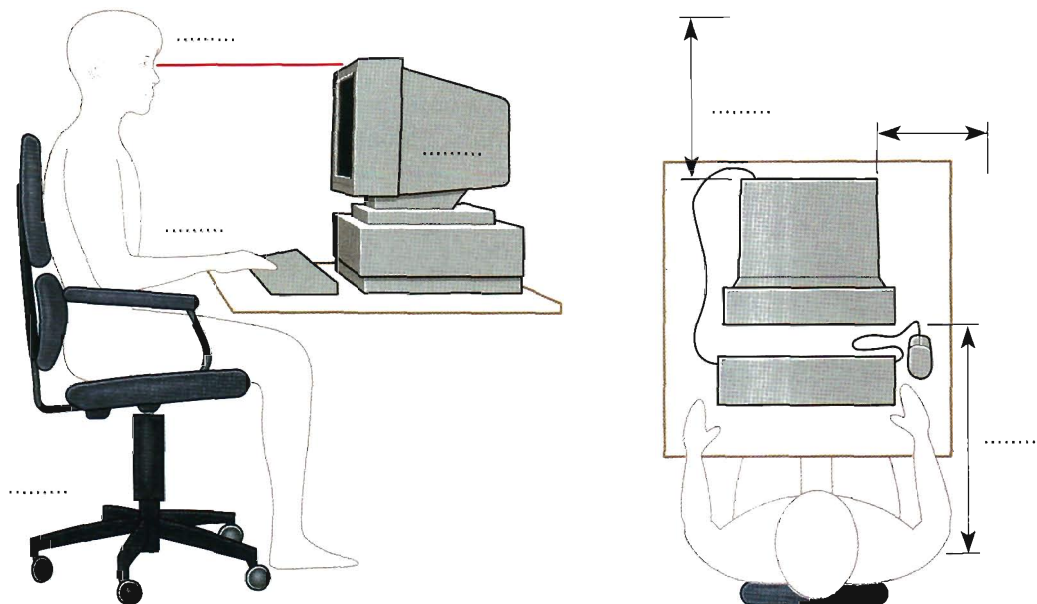

## 5 Language work: Instructions and advice

Look at the HELP box and then rewrite the sentences below about what you should do to protect your eyes. Use modal auxiliary verbs in your sentences.

### HELP box Instructions and advice

Imperatives

**Position** your keyboard at the same height as your elbows.

**Don't use** a monitor that is fuzzy or distorts the image.

Should/ought to

You **should** position your keyboard at the same height as your elbows. = You **ought to** ...

You **shouldn't** use a monitor that is fuzzy or distorts the image. = You **ought not (oughtn't)** to use ...

- 1 Do not stare at the screen for long periods of time.
- 2 Avoid placing the monitor so that it reflects a source of bright light, such as a window.
- 3 Keep the screen clean to prevent distorting shadows.
- 4 If you work in an office with a large number of computers, don't sit too close to the sides or backs of the monitors.
- 5 Buy a protective filter that cuts down the ELF (extremely low frequency) emissions.



Enter the Infotech website at [www.cambridge.org/elt/infotech](http://www.cambridge.org/elt/infotech)

Then go to the Study online section, click on Flat screens and do the activities

# Unit 9 *Choosing a printer*

## 1 Reading

A How many kinds of printers can you think of? Make a list.

B Read the text below and label these types of printers.

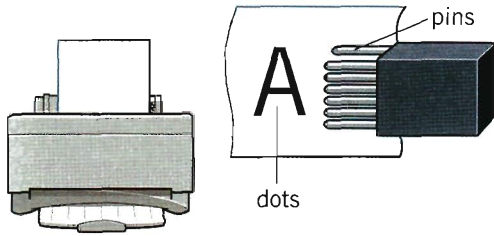

The resolution depends on the number of pins (9, 24 or 48)

1 .....

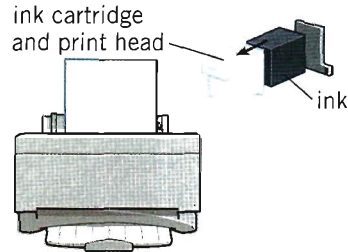

The quality (resolution) of the images ranges from 300 to 1,200 dots per inch (dpi)

2 .....

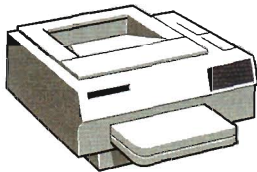

Provides high quality output – a resolution of 600/2,400 (dpi)

3 .....

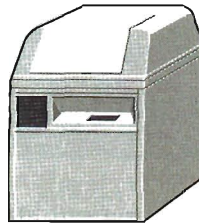

Provides the highest resolution – more than 3,000 dpi

4 .....

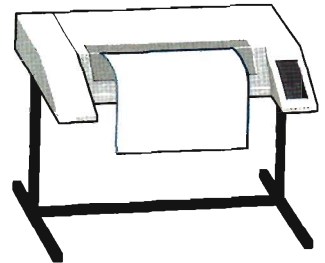

Provides high quality for linework (like lines and curves)

5 .....

### *Types of printers*

Printing is the final stage in creating a document. That is the purpose of the printers joined to your computing equipment. *Since* the results you can obtain with different types of printers will vary substantially, here is a guide to help you decide which one is most suitable for your needs.

*To begin with*, it must be taken into account that printers vary in cost, speed, print quality and other factors such as noise or compatibility. In fact, printing technology is evolving so quickly that there is always a printer for every application or personal requirement.

15 **Dot-matrix** printers use pins to print the dots required to shape a character. They print text and graphics and nowadays some of them can print up to 500 characters per second (cps); *however*, they produce relatively low resolution output – 72 or 144 dots per inch. This level of quality, *while* suitable for preliminary drafts, is not recommended for reports or books that have a wide audience. They are slower than laser printers *but* much cheaper.

One common type of non-impact printer is an **ink-jet** printer. It operates by projecting small ink droplets onto paper to form the required image. This type of printer is quite fast, silent *and* not so expensive as a laser printer. *Nevertheless*, you can expect high quality results *because* there are some ink-jet printers on the market with a resolution of 720 dpi. **Bubble-jet** printers work the same way.

35 **Laser** printers produce output at great speed and with a very high resolution of 600/2,400 dpi. They scan the image with a laser beam and transfer it to paper with a special ink powder. They are constantly being improved. In terms of speed and image quality they are preferred

by experts for different reasons: they have a wider range of scalable fonts, they can emulate different language systems, they can produce graphics, and they have many other advantages. It goes without saying that they are still expensive for home users.

We must not forget to mention **thermal** printers. They use heat, a special kind of paper and electrosensitive methods. They are silent and considered to be inexpensive. However, some colour models that emulate HP (Hewlett Packard) plotters cost too much to be included in the same category.

**Imagesetters** can be regarded as an attractive alternative. They produce very high-resolution output (up to 3,540 dpi) on paper or microfilm. *In addition*, they are extremely fast. They are used in desktop publishing. *Although* they produce the highest quality output, they have one important drawback: they are too expensive for homes or small offices.

*Finally*, **plotters** are a special kind of printer. Plotters use ink and fine pens held in a carriage to draw very detailed designs on paper. They are used for construction plans, engineering drawings and other technical illustrations.

**C** Read the text again and complete this table with the most relevant information. Then compare your notes with a partner.

<i>Type of printer</i>	<i>Technical specifications and other features</i>
Dot-matrix	.....
Ink-jet	.....
Laser	.....
Thermal	.....
Imagesetter	.....
Plotter	.....

## 2 Discourse cohesion

### Reference signals

**A** Read the text and say what the **boxed** words refer to.

Printing is the final stage in creating a document. **That** is the purpose of the printers joined to your computing equipment. Since the results you can obtain with different types of printers will vary substantially, here is a guide to help you decide which **one** is most suitable for your needs.

5 To begin with, it must be taken into account that printers vary in cost, speed, print quality and other factors **such** as noise or compatibility. In fact, printing technology is evolving so quickly that there is always a printer for every application or personal requirement.

10 **They** print text and graphics and nowadays some of **them** can print up to 500 characters per second (cps).

## Linking devices

**B** In pairs, look at the text in Task 1 again and put the words in *italics* into one of the columns in the table below.

<i>Indicating addition</i>	<i>Contrasting</i>	<i>Sequencing</i>	<i>Reason/cause</i>

**C** Write a short text about the pros and cons of a printer or printers you use. Use some linking devices from the list above. Write about these aspects: type, cost, speed, noise, output quality, resident fonts.

## 3 Listening

**A**  Listen to the radio interview and tick (✓) the statements about ink-jet printers that are true.

- 1 Ink-jet printers are quieter than dot-matrix printers.
- 2 Ink-jet printers are cheaper than dot-matrix printers.
- 3 Ink-jet printers are not real competition for laser printers.
- 4 Ink-jet printers can easily print on envelopes, labels and transparencies.
- 5 Ink-jet colour printers use four inks: magenta, yellow, cyan and black.
- 6 Ink-jets are ideal for workgroups and large businesses.

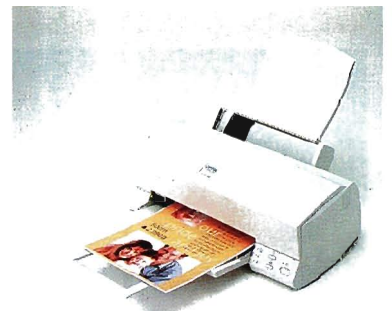

*An ink-jet printer*

**B**  Listen again and, with the help of a partner, correct the statements that are not true.

## 4 Scan reading: Quiz

Read the advertisements for printers below, and then, with your partner, answer the questions. See who in your group/class can finish first.

- 1 How many laser printers are advertised here?
- 2 Is there a printer that operates by spraying ink droplets onto paper?
- 3 Which laser printer offers the highest resolution, or output quality?
- 4 Which printer is the most expensive?
- 5 Which one would you recommend to a friend who does not have much money?
- 6 Which one has more internal fonts?
- 7 A printer language is software that tells printers how to print a document. Can you find two types of laser printer languages?
- 8 What connectivity features are offered by the Turbo Laser Writer QR?
- 9 A very common feature in advertisements is the use of abbreviations. Find the abbreviations for these expressions: *dots per inch*, *characters per second*, *pages per minute*, *small computer system interface* and *liquid-crystal display*.

### Turbo Laser Writer QR

Workgroup laser printer. 15 pages per minute. 1,200 dpi for graphics. 36 MB of RAM. Includes Adobe PostScript and Hewlett Packard PCL printer languages. 75 resident fonts. Connectivity: one bi-directional parallel port, one LocalTalk port, and one Ethernet port for networks. 12 month warranty.

£1,150

### Stylus Dot-matrix Printer

Dot-matrix printer with 24 pins. Prints text and graphics. 450 cps. Compatible special interface. Free unlimited hotline support for our customers. One year on-site maintenance.

£179

### COLOUR POSTSCRIPT PRINTER

Colour printer. 40 Adobe Postscript fonts. 36 MB RAM with a SCSI Interface for an optional 20 MB hard disk. Parallel, serial and AppleTalk interfaces. HP plotter emulation. Thermal printing system. 30-day money-back guarantee and 1 year's on-site parts and labour.

£2,249

### Crystal Laser Printer II

14 pages per minute. 20 MB RAM  
Two 200 sheet selectable input trays.  
LCD display. 80 internal scalable fonts.  
A resolution of 2,400 dpi.  
Comes with PostScript language and PCL (printer control language).  
Telephone hotline support.

£999

### COLOUR INK-JET

Stunning Plug & Play colour printer. Brilliant photo quality (up to 720 dpi) and fast-drying ink. Produces 8 pages per minute in plain text and 4 ppm in colour. 150 page paper tray. Fast, friendly service.

£210

### Micro Laser XT

Personal laser printer. 5 pages per minute. 4 MB RAM expandable to 64 MB. Parallel interface. 200 sheet input tray. 35 resident fonts. One-year on-site maintenance. Prints on a wide range of materials and sizes.

£649

# Unit 10 *I/O devices for the disabled*

## 1 Adaptive technology

Working in pairs or small groups, look at the pictures and discuss these questions. Use the phrases in the box to help you.

- 1 What sort of difficulties do you think are experienced by computer users with limitations of vision or mobility?
- 2 What types of devices could be helpful to blind users?
- 3 How can a person with mobility limitations communicate with a computer? Think of possible tools or solutions.

### Key words

blind person	adapted keyboard
magnification software	on-screen keyboard
Braille printer	voice recognition system
adaptive switch	screen-pointing device
optical head pointer	speech synthesis system
motor-impaired person	pneumatic tube (sip and puff)



## 2 Reading

### A Read the text below and find:

- 1 the name of the law that ensures equal opportunity for persons with disabilities in the US.
- 2 the type of software which is recommended for someone with low or partial vision.
- 3 the type of software that reads printed material, recognizes the text and then sends it to the PC.
- 4 the switch that can be used by someone with quadriplegia.
- 5 the function of voice recognition devices.
- 6 the device used by the disabled person at the Center for the Handicapped in Seattle.
- 7 how the blind student (in the photo) interacts with the machine.
- 8 how Bob Love enters information into the computer.

### *Computers for the disabled*

Computers have taken a dominant role in our society, so most new jobs require access to computers and the Internet. But what happens if a person is blind, deaf or motor-disabled? They needn't worry. The latest assistive technology is designed to help them use computers and do their jobs in the office, learn at school, or interact with their families at home. In addition, new laws oblige employers to adapt the workplace to accommodate disabled people. For example, companies in the USA are subject to the Americans with Disabilities Act or ADA. This makes it illegal for employers to discriminate against people with disabilities.

The first task in adding assistive technology to a computer is to determine the specific needs of the disabled worker in question. To work effectively, most **blind users** need to have their computers adapted with technologies such as Braille, magnification, speech synthesis and Optical Character Recognition (OCR).

*A disabled person using a voice command-activated computer at the Center for the Handicapped in Seattle. He operates the system with a headset microphone, muscle switches and a joystick control.*

Modern Braille keyboards have Braille lettering on keyboard overlays, allowing the blind user to easily identify each key. For Braille output, there are printers that can emboss Braille on both sides of a page at high speed.

For someone with limited but usable vision, a screen magnification program may be appropriate. Magnification programs can enlarge text appearing on the screen by up to 16 times. In addition, they are now being developed with various levels of speech output capabilities, and work with all applications, including the Internet.



35 A speech-synthesis system is used to read aloud the work on the computer. It has a  
speech-synthesizer, which produces the audio output, and a screen reader, the program  
40 which reads aloud text and menus from word processors, databases, and even the Web.



*A blind student using an adapted keyboard, in the presence of his tutor. The headphones and a screen reading program allow him to hear the text from the screen.*

OCR uses a flatbed scanner and specialized OCR software to read printed material and send the text to the computer. Then the PC can produce a copy of the text in Braille, a magnified copy, or a version that can be read aloud by a speech-synthesis system.

45 **Deaf computer users** can overcome many communication difficulties with the aid of visual alerts and electronic note takers.

50 Visual alerts are indicators that alert the deaf user when there is an error. So instead of hearing a sound, the user is alerted by a menu bar blinking or by a message on the screen. Electronic note-takers are devices which print out what is spoken in meetings or business presentations, where lip-reading is not possible.

**Motor-impaired workers** unable to type on a standard keyboard can employ expanded or ergonomic keyboards, on-screen keyboards, adaptive switches and voice recognition systems.

On-screen keyboards are software images of a keyboard that appear on the screen and may be activated with a trackball, touch screen, screen-pointing device, or eye movements. In an eye-gaze system, the keys on the virtual keyboard are activated by the user's eyes when they pause on a key for 2 or 3 seconds.

Switches come in many shapes and sizes. They are operated by muscle movements or breath control. For example, a pneumatic switch – known as 'sip and puff' – allows someone with quadriplegia to control the PC by puffing and sipping air through a pneumatic tube.

Voice-recognition allows the computer to interpret human speech, transforming the words into digitized text or instructions.



*Bob Love was born with no arms. He uses an overlay keyboard with his feet and the computer and monitor on the floor. The key overlays give a much larger surface for each key.*

**B Match the terms in the box with the explanations below.**

a Braille    b speech synthesizer    c electronic note-taker  
d on-screen keyboard    e eye-gaze system

- 1 a keyboard displayed within the computer screen
- 2 a system of writing and reading (using raised dots) for blind people, to enable them to read by touch
- 3 a hardware device used in conjunction with a screen reader program to convert screen contents into spoken words
- 4 a system activated by the movement of the user's eyes
- 5 a device used by deaf users to record and print out what is spoken in a meeting

### 3 Language work: Noun phrases

**A Look at the HELP box and then the noun phrases 1 to 7. Decide what type of modifier(s) is/are placed before the 'head' in each case.****Types of modifiers**

- a adjective
  - b participle
  - c 's genitive
  - d noun
- 1 disabled worker
  - 2 rehabilitation engineer
  - 3 employee's abilities
  - 4 external adaptive switch
  - 5 Windows-based applications
  - 6 pointing device
  - 7 speech synthesizer

**B Explain the following noun phrases.****Examples**

memory chips    *chips of memory*  
disk controller    *a device which controls the disk drive*

- 1 screen reader
- 2 printing devices
- 3 company's database
- 4 adapted keyboards
- 5 magnification program
- 6 eye movements

**HELP box**  
**Noun phrases**

In describing a noun phrase, we can distinguish two components:

- the head
- the modifier – notably adjectives and nouns. Thus:
 

– <i>compatible</i>	<i>computer</i>
modifier	head
– <i>machine</i>	<i>code</i>
modifier	head

We have the following range of modifiers:

- adjectives  
*I like this portable computer.*  
– a computer which is portable
- participles  
*I like this drawing and painting program.*  
– a program that draws and paints  
*I like this pocket-sized computer.*  
– a computer that fits into your pocket
- 's genitive  
*I like the director's computer.*  
– the computer which belongs to the director
- nouns  
*I like this colour scanner.*  
– a scanner which works in colour

## 4 Listening

**A**  **Mike Hartley is a director of the Adaptive Technology Project for the Blind in Washington, DC. Listen to this interview with him in which he discusses the needs of blind computer users and make notes.**

- Work he's involved in: .....
- Minimum configuration required to meet the needs of these workers:  
Processor: .....
- RAM: .....
- Expansion slots: .....
- Specific technologies (input/output devices): .....
- Companies that are developing adaptive equipment: .....

**B Compare your notes in pairs.**

**C**  **Listen again and complete your notes.**

## 5 Writing

**Write a letter to Mike Hartley asking for information about computers for the disabled. Make sure you include the following points.**

- Begin by saying why you're writing:  
*I am writing to ...*
- Ask for information about specific I/O equipment for deaf, blind and motor-disabled workers:  
*I would like to know ...*  
Ask for a free handbook about how to add adaptive technology to personal computers:  
*I would be very grateful if ...*
- End the letter appropriately:  
*I look forward to hearing from you soon.*  
*Yours sincerely ...*



Enter the Infotech website at [www.cambridge.org/elt/infotech](http://www.cambridge.org/elt/infotech).

Then go to the Web links section and do the activity Assistive Technology.

# Storage devices

<b>Unit</b>	<b>page</b>
<b>11</b> <i>Magnetic drives</i>	<b>50</b>
<b>12</b> <i>Optical breakthrough</i>	<b>54</b>

## Learning objectives

*In this section you will learn how to:*

- ask and answer questions about diskettes, hard disks and removable drives
- describe different types of storage devices
- locate specific information in texts about optical disks (CD-ROMs, DVDs)
- use technical vocabulary connected with disks and drives
- give advice and make recommendations about disks and drives.

# Unit 11 *Magnetic drives*

## 1 Types of drives

Look at the illustrations and find out:

- 1 the size of a floppy disk
- 2 the storage capacity of a high density diskette
- 3 the name of a hard drive on a PC platform
- 4 the storage capacity of a SyQuest cartridge
- 5 the system that can hold 10 GB tapes
- 6 a type of drive used by digital cameras and music players.

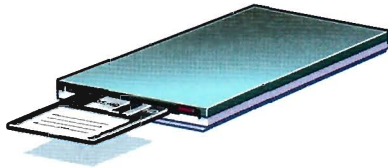

### 3.5-inch diskette

A high-density (HD) floppy disk can store 1.44 MB of information. A floppy drive uses 3.5-inch disks and it's called drive A.

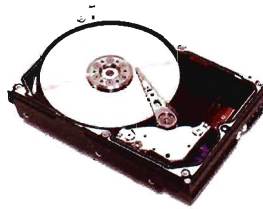

### Hard disk

Most PCs have one hard drive, called drive C. It's used to keep software and files organized in a convenient way. A hard disk can hold several gigabytes of data.



### Removable hard drive

Popular drives are the Zip and Jaz systems from Iomega. A Syquest cartridge can hold 1.5 GB.

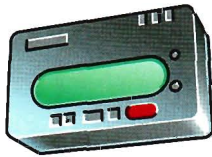

### Tape drive

A tape drive stores data on tape cartridges. It's used for backup purposes. A Digital Audio Tape drive can hold up to 10 GB of data.



### Pocket-sized drive

Ultra portable drives are used with mobile computers. They hold 40 MB disks. The Peerless system can hold 20 GB disks, which allows you to store thousands of MP3s and video games.

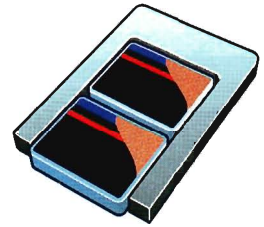

### Microdrive

A Microdrive is the smallest hard drive for digital cameras, laptops, and audio players. It comes in 340 MB and 1 GB capacities. It uses a PC Card adapter.

## 2 Listening

 Sue is in a shop. Listen to the conversation and answer these questions.

- 1 What type of drive does Sue want to buy?
- 2 What's the storage capacity of a Zip disk?
- 3 How much information can be stored on a Jaz disk?
- 4 What type of disk is a good substitute for diskettes?
- 5 How much is a Jaz drive?
- 6 Which system is ideal to store MP3 music and videos – the Jaz or the Peerless?

## 3 Protect your data

### A Match the instructions to the pictures.

- 1 Protect your floppies against high temperatures.
- 2 Check for viruses before opening files you receive from the Web or via e-mail.
- 3 Keep back-ups (spare copies) of your data.
- 4 Magnetic fields can damage the information stored on disks. Don't leave them near the telephone.
- 5 Keep disks away from water and humidity.
- 6 When handling CDs or DVDs, hold the disks around the edge.

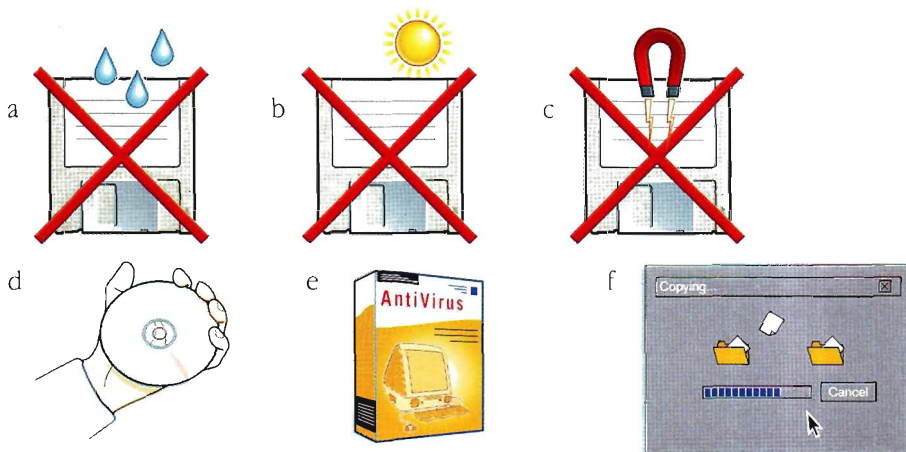

### B In pairs, tell each other what you must or mustn't do to protect your data.

**Example** *You mustn't stack disks on top of each other.*

- 1 disks in a protective case
- 2 into the disk drive very carefully
- 3 near magnets; they can damage the information stored on them
- 4 update your anti-virus program regularly since new viruses are created everyday
- 5 passwords and security devices to protect confidential information

## 4 Reading

### A Read the text and match the terms on the left with the explanations on the right.

- |                      |                                                                         |
|----------------------|-------------------------------------------------------------------------|
| 1 backing store      | a) a catalogue of where each piece of data is stored and how to find it |
| 2 floppies           | b) recording heads                                                      |
| 3 disk drive         | c) secondary memory                                                     |
| 4 formatting         | d) diskettes                                                            |
| 5 directory          | e) initializing; setting tracks and sectors on magnetic disks           |
| 6 read / write heads | f) a device which spins disks and contains a read/write head            |

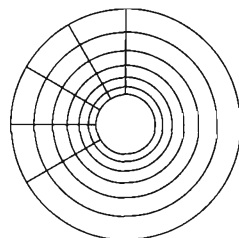

### B Look at the illustration. Identify some tracks and sectors.

## Technical details

**Floppy disks** are so called because they consist of flexible plastic material which has a magnetizable surface.

The surface of a disk is divided into concentric circles or 'tracks', which are then divided into 'sectors'. When you insert a blank disk into a disk drive, it must be 'initialized', or formatted, before information can be recorded onto it. This means that magnetic areas are created for each track and sector, along with a catalogue or 'directory' which will record the specific location of files.

When you save a file, the operating system moves the read/write heads of the disk drive towards empty sectors, records the data and writes an entry for the directory. Later on, when you open that file, the OS looks for its entry in the directory, moves the read/write heads to the correct sectors, and reads the file into the RAM area.

**Hard disks** work in the same way as floppies. But they have important advantages: they can hold much more data and spin at higher speed, so you can store and retrieve information much faster than with floppies. The speed at which a hard drive finds data is called 'access

time' – or seek time. The average access time is measured in milliseconds (ms). Most hard drives have an access time of 8 to 14 ms.

You have to distinguish between access time (e.g. 9 ms) and 'data transfer rate' (the average speed required to transmit data from a disk system to the RAM, e.g. at 10 megabits per second). Remember that the transfer rate depends also on the power of your PC.

If you only use word-processing programs, you will need less storage capacity than if you use CAD, sound and animation programs. If you need an extra hard drive, you should consider the type of mechanism. There are 'internal' and 'external' drives which are both rigid disks sealed into the drive unit, either within or attached to the computer.

Another type of hard drive, known as 'removable', allows you to record data on 'cartridges', which can be removed and stored off-line for security purposes. Some systems allow you to back up your entire PC on one disk.

Laptops use pocket-sized drives. Digital cameras and music players use microdrives with special cards.

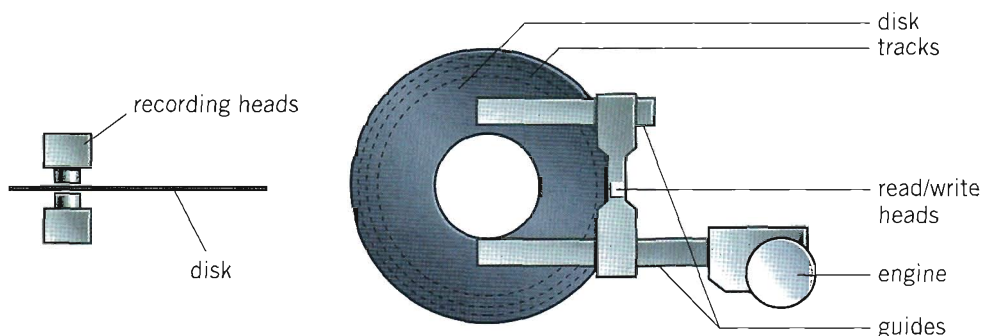

*A floppy disk drive spins at 360 revolutions per minute. A hard disk drive spins at 7,200 rpm and stores data on a stack of metal rotating disks, called platters.*

**C Now read these sentences and decide if they are true (T) or false (F).**

- 1 Hard drives are faster than floppy drives.
- 2 'Access time' refers to the average time required for the recording heads to move and access data.
- 3 'Access time' and 'data transfer rate' mean the same.
- 4 Hard disks use rigid rotating disks.
- 5 A hard drive is about 20 times faster than a floppy disk drive.
- 6 If you use multimedia applications you need the same storage capacity as required for word processors.
- 7 Removable cartridges are not transportable.

## 5 Word building

**Look at the groups of words and decide what class each word belongs to: noun, verb, adjective or adverb.**

**Complete the sentences.**

magnet    magnetic    magnetically  
magnetism    magnetize    magnetized

- 1 ..... is the science of magnetic phenomena and properties.
- 2 Floppy and hard disks are considered as ..... storage devices.
- 3 Data is recorded on a disk in the form of ..... spots called bits.

record /rɪ'kɔ:d/    recorder    recording    recorded

- 4 All disks must be initialized before information can be ..... onto them.
- 5 The ..... heads follow the tracks and magnetize the coating along each track.
- 6 A disk drive works very much like a tape ..... that can both play and record.

fragment    fragmentation    defragmenter  
fragmented

- 7 After you create, delete and modify a lot of files, the hard disk becomes ....., with bits and pieces spread all over the disk.
- 8 ..... slows down the speed at which data is accessed because the disk drive has to work harder to find the parts of a file stored in many different locations.
- 9 To reorganize your hard disk, you can use a disk optimizer or .....; this will reorder your files into contiguous clusters.

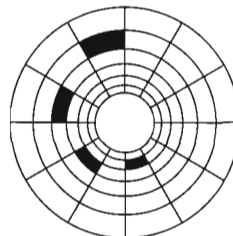

*In a fragmented disk, a file is stored in non-contiguous sectors*

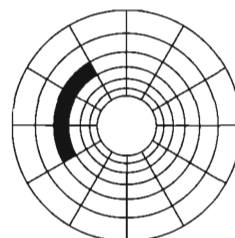

*In a defragmented disk, a file is stored in neighbouring sectors*

# Unit 12 *Optical breakthrough*

## 1 Warm-up

Before listening try to answer these questions.

- 1 What does 'CD-ROM' stand for?
- 2 What kind of technology is used by CD-ROM disks and drives?
- 3 How do you say these expressions in your language?  
compact disk      CD-ROM disk drive  
laser technology      erasable optical disk



## 2 Listening

 Paul (see Unit 5) is now interested in CD-ROMs. He has gone back to his local computer shop to ask for some information.

Read the sentences below, and as you listen put a cross (X) next to those which contain a technical mistake. Then listen again and correct these sentences.

- 1 A CD-ROM disk is very different from a compact music disk.
- 2 You need a hard disk drive to read CD-ROM disks.
- 3 The data on a CD-ROM is read with a laser beam.
- 4 A typical CD-ROM disk can hold 100 MB.
- 5 The data on a CD-ROM can be changed or 'written' to.
- 6 A CD-ROM is a good way of storing large amounts of information (images, sounds, applications, etc.).
- 7 CD-ROM drives cannot play audio CDs.



A CD-ROM

## 3 Reading

**A** What are the advantages and disadvantages of optical disks? Read the text to check your answer.

### *Optical disks and drives*

Optical disks can store information at much higher densities than magnetic disks. Thus, they are ideal for multimedia applications where images, animation and sound occupy a lot of disk space. Besides, they are not affected

by magnetic fields. This means that they are secure and stable, e.g. they can be transported through airport metal detectors without damaging the data. However, optical drives are slower than hard drives. While there are hard

drives with an average access time of 8 ms, most CD-ROM drives have an access time of 150 to 200 ms.

There are various types of optical drives:

- 15 ● **CD-ROM** systems offer everything, from shareware programs to dictionaries and encyclopedias, from multimedia databases to 3-D games. A lot of institutions have discovered that CD-ROM is the most economical way of sharing information. In fact, one CD-ROM disk (650 MB) can replace 20 300,000 pages of text (about 500 floppies), which represents a lot of savings in distributing materials and corporate databases. In addition, CD-ROM drives can play music CDs while you work. Yet CD-ROM technology has one disadvantage: you cannot write anything onto a CD-ROM disk. You can only 'read' it, like a book.
- 25 ● CD-Recorders come in two different forms: **CD-R** and **CD-RW**. CD-R machines record on CD-R (write-once) disks, allowing you to create and duplicate CDs. They are used to back up hard disks or to distribute and archive information. In fact, these systems are the modern version of old WORM (write once, read many) disks. CD-RW (rewritable) disks can be erased and re-used, just as you would do with a hard disk.
- 35

- 40 ● The future of optical storage is called **DVD** (digital versatile disk). A DVD-ROM can hold 17 GB, about 25 times an ordinary CD-ROM. For this reason, it can store a large amount of multimedia software and complete Hollywood movies in different languages. 45 They can also play music CDs and CD-ROMs. However, DVD-ROMs are 'read-only' devices. To avoid this limitation, companies also produce DVD-R and DVD rewritable disks.
- 50 ● **Magneto-optical (MO) drives** use both a laser and an electromagnet to record information. Consequently, MO disks are rewritable, i.e. they can be written to, erased, and then written again. They usually come in two formats: (i) 5.25" cartridges can hold 55 more than 5.2 GB; (ii) 3.5" floptical disks have a capacity of 230 MB to 1.3 GB. They are ideal for back-up and portable mass storage.



A DVD drive

**B Read the text again and summarize in the table the most relevant information.**

	<i>Technical specifications</i>	<i>Use</i>
<b>CD-ROM</b>		
<b>CD-Recorder</b>		
<b>DVD</b>		
<b>Magneto-optical</b>		

## 4 Discourse cohesion

### Reference signals

**A** Read these sentences and clauses and look back at the text in Task 3 to find out what the words in **bold** refer to.

- 1 ... **they** are secure and stable ... (line 6)
- 2 ... **which** represents a lot of savings in distributing materials ... (line 23)
- 3 ... **you** cannot write anything onto a CD-ROM disk. (line 27)
- 4 You can only 'read' **it** ... (line 29)
- 5 Magneto-optical (MO) drives use **both** a laser and an electromagnet to ... (line 50)

### Connectors and modifiers

**B** Look at the expressions in *italics* in these sentences and clauses.

- 1 *Thus*, they are ideal for multimedia applications ...
- 2 *Besides*, they are not affected by magnetic fields.
- 3 *However*, optical drives are slower than hard drives.
- 4 *In addition*, CD-ROM drives can play music CDs while you work.
- 5 *Yet* CD-ROM technology has one disadvantage: ...
- 6 *For this reason*, it can store a large amount of multimedia software ...

Put each expression (1 to 6) into the right category: a, b or c.

- a to show contrast
- b to explain causes and results
- c to add new ideas

## 5 Speaking

Which of the products in the box on page 57 would be most suitable for the purposes below? Discuss the pros and cons with a partner.

- 1 To store data and programs at home.
- 2 To hold large amounts of information in a big company.
- 3 To store an illustrated encyclopedia for children.
- 4 To hold historical records in the National Library.
- 5 To store high-quality audio and video, and hold several movies in different languages.

### Useful expressions

*For personal use, I would recommend ... because ...*     *I agree/disagree with you. CD-ROMs ...*  
*In a big company, it would be a good idea to ...*     *Besides, ...*  
*However, ... is good for an encyclopedia because ...*     *Well, that depends on ...*

## **Products available**

### **Hard disk drive**

Superfast 8 ms hard drive. Capacity ranges from 6 to 80 GB.

### **Imomega's removable drives**

The Zip series uses 100 MB and 250 MB disks. In the near future it could replace the floppy disk as the portable storage medium.

The Jaz series can hold 2 GB cartridges. Ideal to back up hard disks.

### **CD-ROM drive**

Each CD disk holds 650 MB.

### **CD-Recordable drive**

Makes it possible to write data to CDs as well as read it.

### **Magneto-optical (MO) disk systems**

Erasable optical-magnetic 5.25" cartridges with 5.2 GB of storage capacity. Can be erased and written on like a hard disk.

Rewritable 3.5" floptical disks with a storage capacity of 1.3 GB.

### **DAT Data tape drive**

Digital audio tape drives to store computer data. Used for back-up purposes. Slow access. Huge amounts of information (about 10 GB).

### **Digital Video Disk-ROM drive**

Each DVD-ROM disk has a capacity of up to 17 GB, and can hold various full-screen movies. The drive can also read your CD-ROMs.

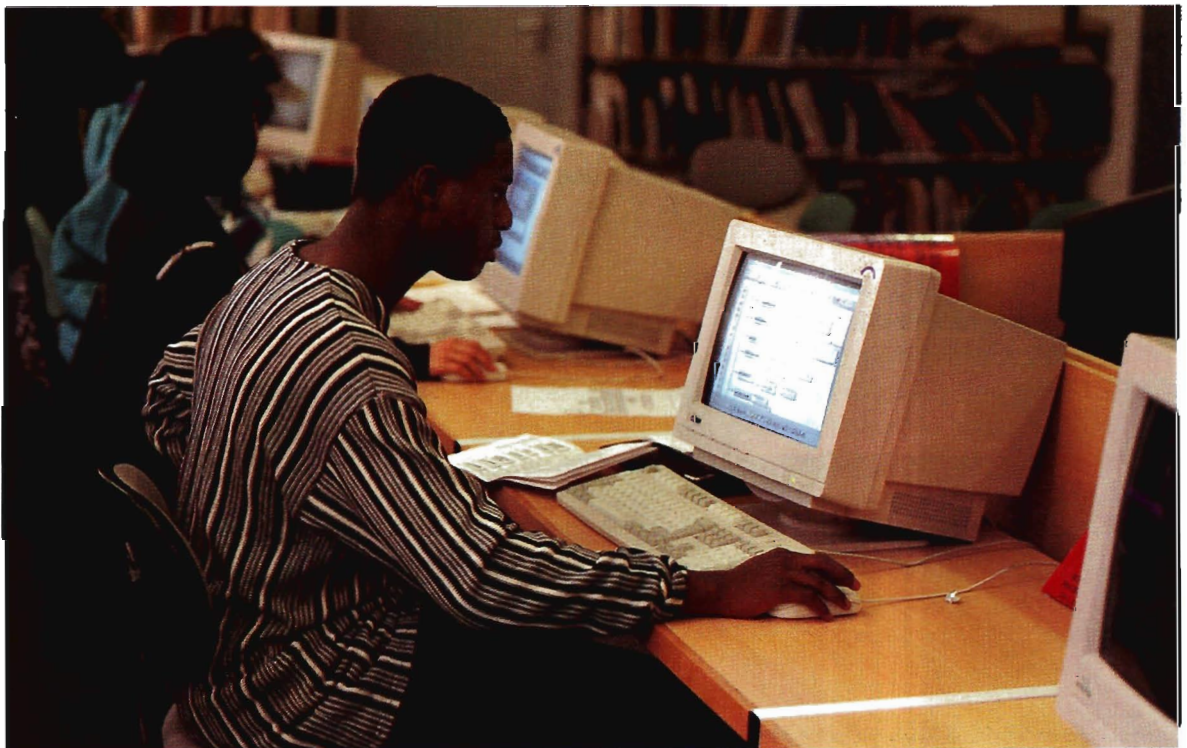

*Students using CD-ROMs*

## 6 Crossword

Read the clues and complete the crossword.

### Across

- 1 Acronym for 'light amplification by stimulated emission of radiation'. (5)
- 4 A microcomputer. (2)
- 6 To write information on a disk, magnetic tape or film. (6)
- 8 To record and keep for future use. (5)
- 12 Abbreviation of 'binary digit'. (3)
- 14 Thousandth of a second. (11)
- 15 The type of computer with a 286 processor introduced by IBM in 1984. (2)
- 17 Concentric ring marked on the surface of a disk when the disk is formatted. (5)
- 18 Prefix meaning 'very large' or 'one thousand million'. (4)
- 20 Read only memory. (3)
- 22 The physical mechanism that accepts, reads and writes data on a disk. (5)

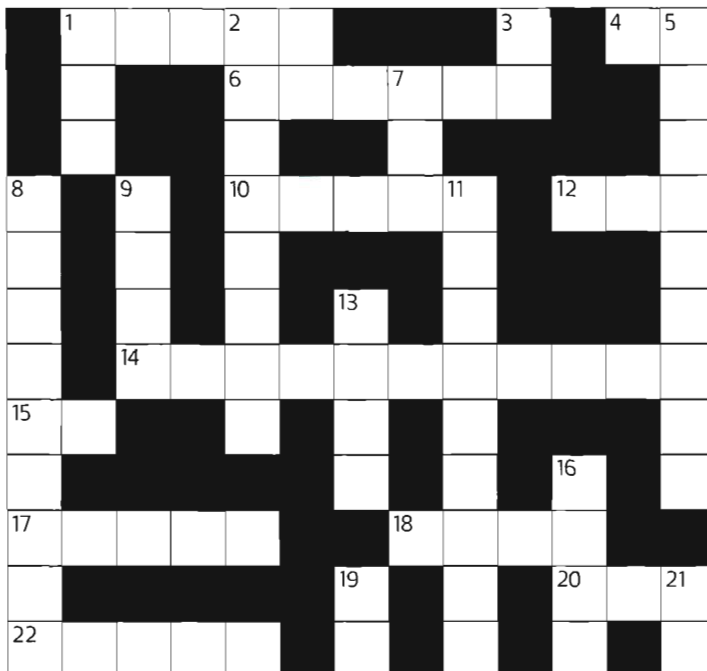

### Down

- 1 Acronym for 'local area network'. (3)
- 2 Opposite of 'indelible'. (8)
- 3 Abbreviation of 'high density' or 'hard disk'. (2)
- 5 Way of storing a lot of information in a removable form. (9)
- 7 Abbreviation of 'optical character recognition'. (3)
- 8 All disks must be 'initialized' or ..... when used for the first time. (9)
- 9 Indelible optical storage device: 'write once, read many'. (4)
- 11 Not cheap. (9)
- 13 A flat, circular surface used to hold computer data. (4)
- 16 Opposite of 'soft'. (4)
- 19 Disk that holds music. (2)
- 21 A thousand kilobytes. (2)



Enter the Infotech website at [www.cambridge.org/elt/infotech](http://www.cambridge.org/elt/infotech)

Then go to the **Web links** section and do the activity **DVD technologies**

# Basic software

Unit	page
13 <i>Operating systems</i>	60
14 <i>The graphical user interface</i>	64
15 <i>A walk through word processing</i>	68
16 <i>Spreadsheets</i>	74
17 <i>Databases</i>	77
18 <i>Faces of the Internet</i>	82

## Learning objectives

***In this section you will learn how to:***

- extract relevant information from texts about system software
- recognize the characteristics of a typical graphical user interface or GUI
- make a summary of a written text
- talk about word processors
- identify the function of different word-processing capabilities: search and replace, cut and paste, spell checkers, etc.
- understand the basic features of spreadsheets and databases
- acquire specific vocabulary related to Internet utilities.

# Unit 13 *Operating systems*

## 1 Warm-up

**A** Look at the diagram. What is the function of the operating system?

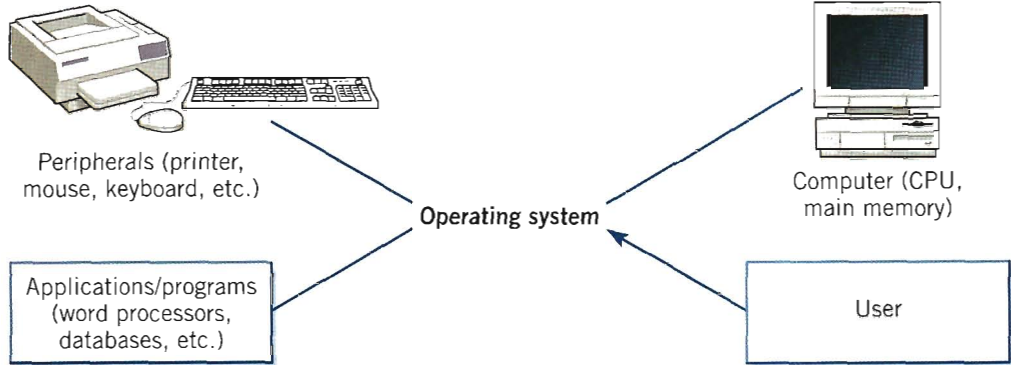

**B** Read the text below and complete it with the phrases in the box.

applications software    operating system    software    system software

Information provided by programs and data is known as (1) .....  
Programs are sets of instructions that make the computer execute operations and tasks. There are two main types of software:

- The (2) ..... refers to all the programs which control the basic functions of a computer. They include operating systems, system utilities (e.g. an anti-virus program, a back-up utility) and language translators (e.g. a compiler – the software that translates instructions into machine code).
- The (3) ..... refers to all those applications – such as word processors and spreadsheets – which are used for specific purposes. Applications are usually stored on disks loaded into the RAM memory when activated by the user.

The (4) ..... is the most important type of system software. It is usually supplied by the manufacturers and comprises a set of programs and files that control the hardware and software resources of a computer system. It controls all the elements that the user sees, and it communicates directly with the computer. In most configurations, the OS is automatically loaded into the RAM section when the computer is started up.

## 2 Reading

### Read the text and find:

- 1 the text-based operating system used in older PCs
- 2 the most secure and reliable version of the Windows family
- 3 the OS designed for handheld computers
- 4 the function of the Finder in Macintosh computers
- 5 the meaning of 'multi-tasking'
- 6 the OS written in C language and used on minicomputers and workstations
- 7 the OS that is freely redistributable under the GNU general public licence
- 8 the OS originally developed to run on SPARC workstations.

### Operating systems

#### MS-DOS

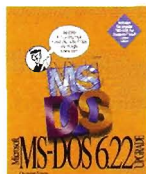

This operating system was developed by Microsoft in 1981 for all IBM PC compatibles. Today it's only used in old PCs. In this text-based OS, you communicate with the computer by typing commands that exist within its library. For example, some basic DOS commands include: DIR (shows a list of all the files in a directory), COPY (makes a duplicate of a file), DEL (deletes files).



Most home PCs use Windows. Here are the most recent versions:

- With **Windows 98**, Internet access becomes part of the user interface. Its active desktop lets you find information easily with the same view of content on your PC, network or the Web. The system includes Outlook Express for e-mail, NetMeeting conferencing software, a chat program and a Web-page editor. It offers advancements such as USB and multimedia extensions.
- **Windows 2000** is built upon the Windows NT architecture and designed for business uses.
- **Windows Millennium** is designed for home use. It includes new system safeguards and support for DVD, music players and mobile computers.
- **Windows XP** is an update to all Windows versions, with a new visual design. It's more secure and reliable. It offers support for the latest technologies.

#### Pocket PC (Microsoft)



This OS is developed for handheld computers (or palmtops) that use a stylus or a small keyboard for input.

#### Mac OS

The Mac OS combines the elegance of Macintosh and the power of UNIX. Large parts of the Mac OS are inside the System file and the Finder, kept in the System folder. The content of the System file is loaded automatically at start-up, and contains information which modifies the routines of the OS in the ROM chips. The Finder displays the Macintosh's desktop and enables the user to work with disks, programs and files. With the new Mac OS, you can create CDs and record DVDs. It also offers Internet capabilities, support for Java, and AirPort technology for wireless connections.

<p><b>OS/2 Warp</b> (IBM)</p> 	<p>This is the PC world's most technically sophisticated operating system. It provides true multi-tasking, allowing a program to be divided into 'threads', many of which can run at the same time. Thus, not only can numerous programs run simultaneously, but one program can perform numerous tasks at the same time.</p> <p>The IBM OS/2 Warp includes easy access to networks via modem, support for Java applications, and voice recognition technology.</p>
<p><b>UNIX</b></p>	<p>This OS, designed by Bell Laboratories for minicomputers and workstations, has been widely adopted by many corporate installations. From the very first, it was designed to be a multi-tasking system. It is written in C language.</p> <p>It has become an operating environment for software development, available for any type of machine, from IBM PCs to Macs to Cray supercomputers. Unix is the most commonly used system for advanced CAD programs.</p>
<p><b>Linux</b> (Linus Torvalds)</p>	<p>Protected under the GNU general public licence, Linux is the open source, cooperatively-developed POSIX-based, multi-tasking operating system. Linux is used as a high value, fully-functional UNIX workstation for applications ranging from Internet Servers to reliable work group computing. Linux is available for Intel, Alpha and Sun SPARC platforms.</p>
<p><b>Solaris</b></p>	<p>This is a Unix-based operating system developed by Sun Microsystems. Originally designed to run on SPARC workstations, today Solaris also runs on many Pentium servers. It supports multi-processing – many CPUs and processes on a single system. It includes Java technology, which allows Web pages to display animation, play music and interact with information.</p>

### 3 Language work

- A Here are some common nouns in computing. Divide them into countable and uncountable nouns. Look at the HELP box and use a dictionary if necessary.**

- |           |            |               |
|-----------|------------|---------------|
| 1 window  | 2 robotics | 3 hardware    |
| 4 program | 5 hacker   | 6 hacking     |
| 7 system  | 8 software | 9 workstation |

- B These sentences contain typical errors. Correct them.**

- We are having a terrivel weather.
- Can you give me an advice?
- I need some informations.
- The news were very depressing.
- I like the furnitures.
- Much people use the Web today.

#### HELP box

##### Countable and uncountable nouns

- **Countable** nouns are people or things that we can count. They have a singular and a plural form. They must have a determiner (*a, one, my, this, ...*) in the singular, though this is not necessary in the plural.  
e.g. *computer, website, bookmark*
  - **Uncountable** (mass) nouns are things that we can't count. They have no plural form.  
e.g. *information, pirating, storage*
  - They are partly distinguished by the determiners they take.  
*Many, few, a few* go with countable nouns.  
*We didn't take many pictures.*  
*I have a few jobs to do.*
- Much, little, a little, a great deal* only go with uncountable nouns.  
*We didn't do much shopping.*  
*I have little work to do.*

**C Complete this text with a, an, the (or nothing at all) as necessary.**

At school we have (1) ..... computer in every classroom. We use (2) ..... computer to do (3)..... projects and to study (4)..... music and languages. The teachers use PCs to print articles, songs, or activities for use in class. This year, they are preparing (5)..... exchange with a college in Norfolk. We all use it to get (6)..... information from (7)..... Internet.

At home I use my computer to send and receive (8)..... e-mail and to play (9)..... computer games. I have (10)..... ink-jet printer.

*Some, any, no, enough* can go with both countable and uncountable nouns.

*We listened to some music.*

*Did you buy any CDs?*

*I don't have enough money.*

- Some words are countable in most languages, but uncountable in English and are used with a singular verb:

*advice, damage, equipment, furniture, research, luggage, news, progress, homework, weather*

## 4 Listening

**A  Read the information in the box and then listen to four advertisements from a radio programme about computers.**

**System utilities** are small programs which improve a system's performance and help users take advantage of the computer's capabilities. They are often desk accessories that can be called up while you're working in another application. They can also be INITs, i.e. system extensions which are activated

when you turn on the computer, control devices which you adjust in the control panel, or even stand-alone programs that run when you need them. Utilities are available for back-up, file search, virus protection, disaster recovery, and so on.

**Number these system utilities in the order in which you hear them.**

- screen saver
- virus detector
- crashed disk rescuer and data recovery
- multimedia player

**B  Listen again. Which utility would you use for each of these requirements?**

- 1 To play and organize multimedia on your PC. ....
- 2 To diagnose and repair damaged disks. ....
- 3 To automatically blank out the screen after a specific interval of inactive time (so that the image does not burn into the screen). ....
- 4 To protect your system against computer viruses. ....



Enter the Infotech website at [www.cambridge.org/elt/infotech](http://www.cambridge.org/elt/infotech)

Then go to the **Web links** section and do the activity **Computer viruses**

## 1 A user-friendly interface

The picture below illustrates a user interface based on graphics.

Read the definitions in the HELP box and then find the following interface elements in the picture:

- 1 window
- 2 scroll bars
- 3 menu bar
- 4 pull-down menu
- 5 pointer
- 6 toolbar buttons
- 7 disk icons
- 8 folders
- 9 program icons
- 10 document icons
- 11 printer icon
- 12 dock icons

### HELP box

- **window:** a viewing area less than or equal to the screen size. By using different windows you can work on several documents or applications simultaneously
- **pull-down menu:** a menu that the user 'pulls down' from a name in the menu bar at the top of the screen by selecting the name with the mouse
- **the pointer:** an arrow, controlled by the mouse, that allows you to move around the screen
- **toolbar buttons:** found at the top of a window, they take you to the Home folder and others.
- **icons:** graphic images (or intuitive symbols) used to represent an object or task
- **folders:** containers for documents and applications
- **dock:** set of icons at the bottom of the screen that give you instant access to the things you use most



The interface elements of the Macintosh

## 2 Reading

**A** Read the article below and decide which of the expressions in the box best describe a graphical user interface (GUI).

user-friendly    slow    attractive    text-based    complex    graphics-based

### GUIs

The term **user interface** refers to the standard procedures the user follows to interact with a particular computer. A few years ago, the way in which users had access to a computer system was quite complex. They had to memorize and type a lot of commands just to see the content of a disk, to copy files or to respond to a single prompt. In fact, only experts used computers, so there was no need for a user-friendly interface. Now, however, computers are used by all kinds of people and as a result there is a growing emphasis on the user interface.

A good user interface is important because when you buy a program you want to use it easily. Moreover, a graphical user interface saves a lot of time: you don't need to memorize commands in order to execute an application; you only have to point and click so that its content appears on the screen.

Macintosh computers – with a user interface based on graphics and intuitive tools – were designed with a single clear aim: to facilitate interaction with the computer. Their interface is called **WIMP: Window, Icon, Menu (or Mouse) and Pointer** (see p. 64) and software products for the Macintosh have been designed to take full advantage of its features

using this interface. In addition, the ROM chips of a Macintosh contain libraries that provide program developers with routines for generating windows, dialog boxes, icons and pop-up menus. This ensures the creation of applications with a high level of consistency.

Today, the most innovative GUIs are the Macintosh, Microsoft Windows and IBM OS/2 Warp. These three platforms include similar features: a desktop with icons, windows and folders, a printer selector, a file finder, a control panel and various desk accessories. Double-clicking a folder opens a window which contains programs, documents or further nested folders. At any time within a folder, you can launch the desired program or document by double-clicking the icon, or you can drag it to another location.

The three platforms differ in other areas such as device installation, network connectivity or compatibility with application programs.

These interfaces have been so successful because they are extremely easy to use. It is well known that computers running under an attractive interface stimulate users to be more creative and produce high quality results, which has a major impact on the general public.

**B** Look at the text again and guess the meaning of these words in your own language.

- 1 user interface (line 1)    2 commands (line 6)    3 tools (line 21)  
 4 program developer (line 30)    5 platform (line 36)  
 6 desktop (line 37)    7 file finder (line 38)    8 nested folders (line 42)

**C Find answers to these questions.**

- 1 What does the abbreviation 'GUI' stand for?
- 2 What is the contribution of Macintosh computers to the development of graphic environments?
- 3 What does the acronym 'WIMP' mean?
- 4 What computing environments based on graphics are mentioned in the text?
- 5 How do you run a program on a computer with a graphical interface?
- 6 Can you give two reasons for the importance of user-friendly interfaces?

### 3 Listening

 Listen to this radio interview with Bill Thompson, a program developer. He is talking about Microsoft Windows. Complete this fact file.

<i>Why it's so popular</i>	<i>Windows versions</i>	<i>Other features</i>	<i>Internet connections</i>	<i>Windows programs</i>
(1) ....., because everything is presented in graphic images. (2) ..... with thousands of programs and allows multi-tasking.	Older versions like Windows 98 and Windows 2000 have been replaced by the new Windows XP. (3) ..... is ideal for home users. (4) ..... is aimed at business users.	Offers support for the latest technologies. Includes Windows (5) ....., a program that lets you play music CDs and videos.	Internet Explorer is more reliable and secure. A connection Firewall protects your PC from (6) .....	The most popular is (7) ....., a suite that includes a word processor, an e-mail program, a spreadsheet, and a presentation graphics program.

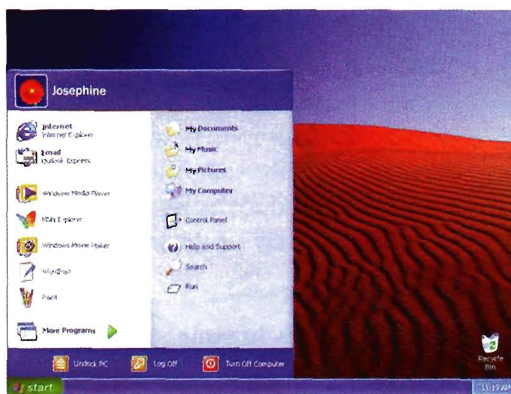

A sample screen from Windows XP

## 4 Writing

Summarize the text in Task 2 in 70–75 words. You may like to follow these steps.

- 1 Read through the whole text again and think of a suitable title for it.
- 2 Make sure you understand all the main points. Go through the text and **underline** the relevant information in each paragraph.
- 3 **Make notes** about the main points:
  - omit repetitions and unnecessary phrases
  - leave out details, such as examples.
 E.g. notes on the first paragraph: *In the past only experts used computers. But now, emphasis on user-friendly interfaces.*
- 4 **Make sentences** from the notes and connect the sentences by using **linking** words (*and, but, also, because, that's why, in fact, therefore*, etc.). Write your **first draft**.
- 5 Improve your first draft by **reducing sentences** (see HELP box below).
- 6 Check grammar, spelling and punctuation. Write the **final version** of your summary.

### HELP box

#### Ways of reducing sentences

- Transform a relative clause into an *-ing* participle clause  
e.g. *Icons are graphic images that represent tasks ...*  
= *Icons are graphic images **representing** tasks.*
- Take out relative pronouns where possible  
e.g. *The software (that) we bought last year ...*
- Omit qualifying words (adjectives or modifying adverbs)  
e.g. *(quite) complex/(very) similar*
- Take out *that* in reported speech or thought  
e.g. *It is well known (that) computers ...*  
*I think (that) there's something wrong with this program.*
- Cut out unnecessary phrases  
e.g. *Macintosh computers were designed with a clear aim: to facilitate the user's interaction with the computer.*  
= *Macintosh machines were designed to facilitate the user's interaction with the computer.*



Enter the Infotech website at [www.cambridge.org/elt/infotech](http://www.cambridge.org/elt/infotech)

Then go to the Study online section, and do the activity A Virtual Interface

## 1 Before you read

Try to answer these questions.

- 1 What is a word processor?
- 2 What makes word processors superior to traditional typewriters?
- 3 Make a list of the most important features offered by word processors.

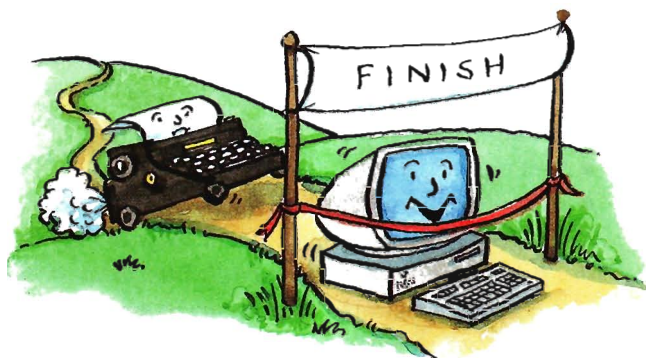

## 2 Reading

- A** Read the text on page 69 and underline any word-processing capabilities that you did not list in Task 1.

File Edit View Insert Format Font Tools Table Window Work Help 3:58 PM

Normal Times 12 B I U

Landscape Estimate

**THE TERRA FIRM**

*estimate*

Thank you for considering The Terra Firm for your landscaping redesign. It was a pleasure meeting you last week. Please see the chart below for a cost breakout of the project. The work plan entails terracing the front hill slope, replanting 60% of your vegetation (including shrubs, perennials, herbs, etc.), and laying a limestone walkway (we recommend a 12-inch, light-grained paver that styles and without grout or mortar).

Per your request, we are currently searching our inventory for a selection of perennial plants that will bloom in colorful all year long. In our region, these style of plants are best bedded in a medium-grade mulch or a sandy loam to avoid exposure to excess moisture. Many of the flowering plants we are considering can be viewed on The Terra Firm Web site at <http://www.theterrafirm.com>. We look forward to hearing from you and anticipate creating the garden you've always dreamed of.

PHASE 1	PHASE 2
Tree Grass Shrub Re	
Replacement of Vegetat	
Walkway	

Page 1 Sec 1 1/1 At 1 Ln 1 Col 1

A screen from Microsoft Word for the Macintosh Word for Windows works the same way WordPerfect, Lotus Word Pro and Nisus Writer also have multiple typefaces, windows, pull-down menus and other graphical tools

## Word-processing facilities

Writing letters, memos or reports are the ways most people use computers. They manipulate words and text on a screen – primarily to print at some later time and store for safe keeping. Computers alleviate much of the tedium associated with typing, proofing and manipulating words. Because computers can store and recall information so readily, documents need not be retyped from scratch just to make corrections or changes. The real strength of word processing lies in this ability to store, retrieve and change information. Typing is still necessary (at least, for now) to put the information into the computer initially, but once in, the need to retype only applies to new information.

Word processing is more than just typing, however. Features such as **Search** and **Replace** allow users to find a particular phrase or word no matter where it is in a body of text. This becomes more useful as the amount of text grows.

Word processors usually include different ways to view the text. Some include a view that displays the text with editor's marks that show hidden characters or commands (spaces, returns, paragraph endings, applied styles, etc.). Many word processors include the ability to show exactly how the text will appear on paper when printed. This is called WYSIWYG (What You See Is What You Get, pronounced 'wizy-wig'). WYSIWYG shows **bold**, *italic*, underline and other type style characteristics on the screen so that the user can clearly see what he or she is typing. Another feature is the correct display of different typefaces and **format** characteristics (margins, indents, super- and sub-scripted characters, etc.). This allows the user to plan the document more accurately and reduces the frustration of printing something that doesn't look right.

Many word processors now have so many features that they approach the capabilities of **layout applications** for desktop publishing. They can import graphics, format multiple columns of text, run text around graphics, etc.

Two important features offered by word processors are automatic **hyphenation** and **mail merging**. Automatic **hyphenation** is the splitting of a word between two lines so that the text will fit better on the page. The word processor constantly monitors words typed and when it reaches the end of a line, if a word is too long to fit, it checks that word in a hyphenation dictionary. This dictionary contains a list of words with the preferred places to split it. If one of these cases fits part of the word at the end of the line, the word processor splits the word, adds a hyphen at the end and places the rest on the next line. This happens extremely fast and gives text a more polished and professional look.

**Mail merge** applications are largely responsible for the explosion of 'personalized' mail. Form letters with designated spaces for names and addresses are stored as documents with links to lists of names and addresses of potential buyers or clients. By designating what information goes into which blank space, a computer can process a huge amount of correspondence substituting the 'personal' information into a form letter. The final document appears to be typed specifically to the person addressed.

Many word processors can also generate tables of numbers or figures, sophisticated indexes and comprehensive tables of contents.

(Adapted from *Understanding Computers*, N. Shedroff et al. Sybex)

**B Look at the words in the box and complete the following sentences with them. Use the information in the text or Glossary if necessary.**

type style    WYSIWYG    format    indent  
font menu    justification    mail merging

- 1 ..... stands for 'What you see is what you get'. It means that your printout will precisely match what you see on the screen.
- 2 ..... refers to the process by which the space between the words in a line is divided evenly to make the text flush with both left and right margins.
- 3 You can change font by selecting the font name and point size from the .....
- 4 ..... refers to a distinguishing visual characteristic of a typeface; 'italic', for example is a ..... that may be used with a number of typefaces.
- 5 The ..... menu of a word processor allows you to set margins, page numbers, spaces between columns and paragraph justifications.
- 6 ..... enables you to combine two files, one containing names and addresses and the other containing a standard letter.
- 7 An ..... is the distance between the beginning of a line and the left margin, or the end of a line and the right margin. Indented text is usually narrower than text without .....

**C Match the words and expressions on the left with their explanations on the right.**

- |                         |                                                                                                                |
|-------------------------|----------------------------------------------------------------------------------------------------------------|
| 1 retrieve              | a text printed in the top margin                                                                               |
| 2 typefaces             | b recover information from a computer system                                                                   |
| 3 header                | c letter, number or symbol that appears below the baseline of the row of type; commonly used in maths formulas |
| 4 footer                | d text printed in the bottom margin                                                                            |
| 5 subscripted character | e division of words into syllables by a short dash or hyphen                                                   |
| 6 hyphenation           | f styles for a set of characters; sometimes called 'fonts'                                                     |

### 3 Listening

Two friends are talking about how to move text by using the 'Cut and Paste' technique. Read the conversation and complete it with words from the box.

Finally    command    First    Edit  
now    mistake    Next    insertion

A: Do you know how I can move this paragraph? I want to put it at the end of this page.

B: Er ... I think so. (1) ..... you use the mouse to select the text that you want to move ... and then you choose the Cut (2) ..... from the Edit menu ...

A: Like this?

B: Yes. The selected text disappears and goes onto the Clipboard. And (3) ..... you find where you want the text to appear and you click to position the (4) ..... point in this place.

A: Mm ... is that OK?

B: Yes, if that's where you want it. (5) ..... choose Paste from the (6) ..... menu, or hold down Command and press V. (7) ..... check that the text has appeared in the right place.

A: What do I do if I make a (8) ..... ?

B: You can choose Undo from the Edit menu which will reverse your last editing command.

A: Brilliant! Thanks a lot.

B: That's OK.

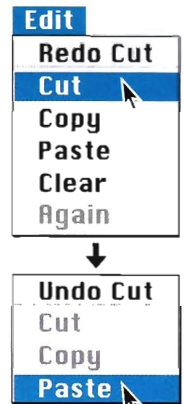

 Now listen to check your answers.

## 4 Writing

Moving text is a process of cutting and pasting, as if you were using scissors and glue. The picture below represents this process. Write a short description of it.

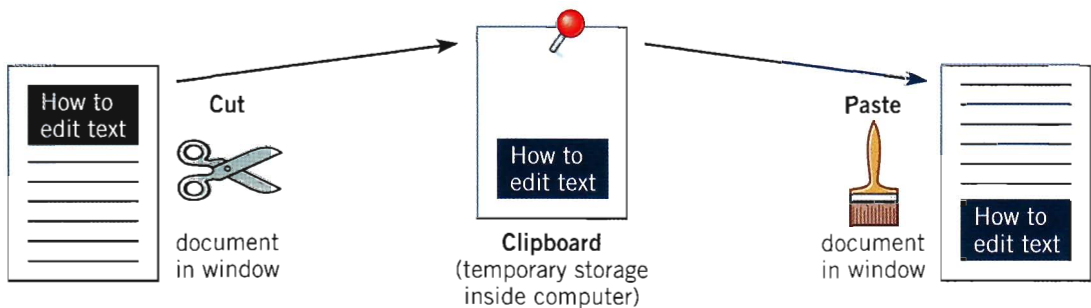

## 5 Writing tools

**A** Three major features that word processors offer are spell checkers, online thesauruses and grammar checkers. Read the descriptions of these features and match them with the windows or dialog boxes.

- 1 **Spell checkers** can be used to compare words in the program's dictionary to those used in the user's document. The spell checker points out any words it cannot match, notifies the user and allows them to make any changes; it sometimes even suggests possible correct spellings.

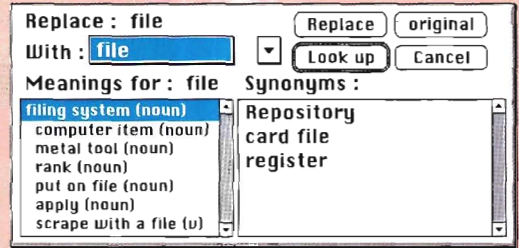

a

Like a conventional thesaurus, this database of words contains definitions and suggestions of words with similar and opposite meanings. A word may be spelled correctly but still be wrong (*too* instead of *two*, for instance). This is a good first step at proofing a document because it can find many common errors, but users will still need to proofread documents to ensure complete accuracy.

- 2 Many word processors include an **online thesaurus** with which users can look up different words to use in similar instances. Their power comes not from knowing every grammatical rule, but from questioning the writer about certain parts of the text. Some even include information about pronunciation and histories of evolving meaning.

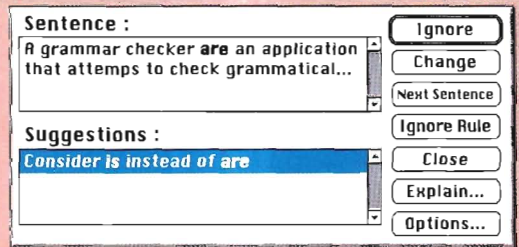

b

- 3 **Grammar checkers** are applications that attempt to check more than just spelling. They count words in sentences to flag possible run-on sentences. They look for words that show possible conflicts

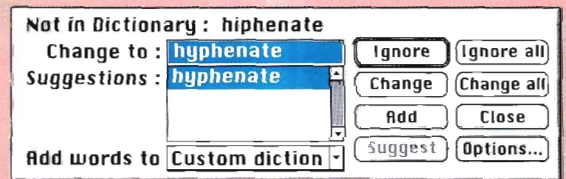

c

between verbs and subjects and they offer advice about corrections. Grammar checkers are a step beyond spell checkers, but they are still not a substitute for a human editor. However, this does not mean that all of the words in the document are spelled correctly. This gives the writer another chance to think about what he or she has written; the computer can alert writers to problems that wouldn't be obvious to them otherwise.

(Texts adapted from *Understanding Computers*, by N. Shedroff *et al.* Sybex, 1993)

- B** Read through the descriptions again. There are three sentences which have been printed in the wrong position. Decide which are the intruding sentences and where they should go.

## 6 Speaking

Work in pairs. Read the table below which summarizes the most relevant features of two word-processing programs. The characteristics of each program are marked with a tick (✓). Student A has *Printext* and Student B has *Publisher*. Explain to your partner why your program is better.

### Example

- A: With Printext I can ...  
 B: Yes, but you can't ...  
 A: However, it is possible to ... whereas with Publisher you can't ...  
 B: Yes, but don't forget that with Publisher you can ... Moreover, ...  
 A: OK. I understand what you mean, but what about ...?

<i>Characteristics</i>	<i>Student A Printext</i>	<i>Student B Publisher</i>
1 Instantaneous WYSIWYG and editing	✓	✓
2 Variety of font types, styles and size	✓	✓
3 Editing facilities: Copy, Cut, Paste, Undo, Select All	✓	✓
4 Centring and indenting paragraphs. Special column formats. Hyphenation and justification of text with optimum line-breaking	✓	✓
5 Spell checker, grammar checker and thesaurus	✓	✓
6 Can find and replace words even in unopened files	✓	
7 Automatic numbering of chapters and sections. Automatic generation of indexes and tables of contents. Cross-reference facilities		✓
8 Allows you to generate maths formulas, and diagrams		✓
9 Graphics tools: You can have the text wrap around the graphic or flow through it. You can scale and rotate graphics	✓	
10 Import and export facilities. You can transfer files to other IBM PCs and Macintosh applications	✓	
11 You can record voice annotations to insert comments into a document		✓
12 Includes Internet connection tools and allows you to create HTML pages for the Web		✓

# Unit 16 Spreadsheets

## 1 Looking at a spreadsheet



Look at this spreadsheet and try to answer the questions.

- 1 What is a spreadsheet?  
What is it used for?
- 2 In a spreadsheet, there are 'columns', 'rows' and 'cells'. Give an example of each from the sample spreadsheet.
- 3 What type of information can be keyed into a cell?
- 4 What will happen if you change the value of a cell?

	A	B	C	D	E
1		2001	2002		
2	Sales	\$890	\$982		
3	Stocks/Shares	487	760		
4	Interest	182	324		
5	Total Revenue	1559	2066		
6					
7	Payroll	894	904		
8	Publicity	399	451		
9	Services	438	372		
10	Total Expenses	1731	1727		
11					
12	TOTAL	-172	339		
13					
14					

*This sample spreadsheet shows the income and expenses of a company. Amounts are given in \$millions*

## 2 Listening

- A**  Listen to Lucy Boyd, a software developer, talking about spreadsheet programs and the spreadsheet above and check your answers to Task 1.
- B**  Listen again and decide whether these sentences are Right (✓) or Wrong (X).
- 1 A spreadsheet program displays information in the form of a table, with a lot of columns and rows.
  - 2 In a spreadsheet you can only enter numbers and formulas.
  - 3 In a spreadsheet you cannot change the width of the columns.
  - 4 Spreadsheet programs can produce visual representations in the form of pie charts.
  - 5 Spreadsheets cannot be used as databases.



*Microsoft Excel is a typical spreadsheet program*

**C** Look at the spreadsheet in Task 1 again and mark the boxes with a ✓ or an X. Then check your answers with another student.

- 6 The value of the cell C12 is the result of applying the formula 'C5 - C10'.
- 7 The cell B5 is the result of adding the values in cells B2 and B3.
- 8 If you type the value '800' in C3, the values in cells C5 and C12 will be recalculated.

### 3 Vocabulary

Match the terms in the box with the explanations below.

a formula    b cell    c sales    d payroll    e share(s)    f revenue  
g interest    h expenses

- 1 A sum of money that is charged or paid as a percentage of a larger sum of money which has been borrowed or invested, e.g. *High ~ rates./7 per cent ~ on a loan.*
- 2 The intersection of a column and a row in a spreadsheet, e.g. *the ~ B2.*
- 3 The quantity sold, e.g. *The ~ of PCs rose by 10 per cent last year.*
- 4 The income – or money – received by a company or organization, e.g. *The annual ~ of this multinational company is ...*
- 5 A ~ in a company is one of the equal parts into which the capital of the company is divided, entitling the holder of the ~ to a proportion of the benefits, e.g. *£10 ~s are now worth £11.*
- 6 Financial costs; amounts of money spent, e.g. *Travelling ~.*
- 7 A function or operation that produces a new value as the result of adding, subtracting, multiplying or dividing existing values, e.g. *If we enter the ~ B5-B10, the program calculates ...*
- 8 **1** A list of people to be paid and the amount due to each. **2** Wages or salaries paid to employees, e.g. *He was on the company's ~.*

### 4 Graphic representation

- A** Look at the graph on page 76 and, with the help of a partner, check that it is an exact visual representation of the spreadsheet in Task 1.
- B** Can you calculate the net profits of this firm during the period 2001–2?
- C** What type of image is this: a pie chart, a bar chart, an area graph or a line graph?

**D** What is the advantage, if any, of displaying information as a graph, rather than as a spreadsheet?

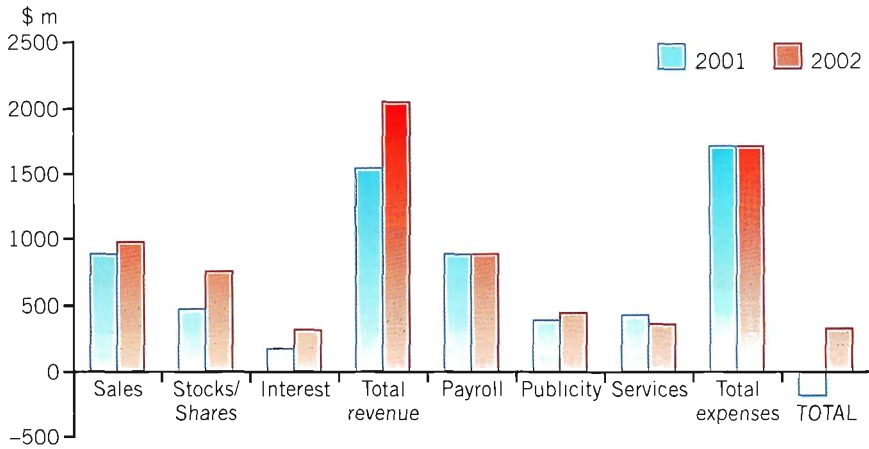

## 5 Extension

**A** Spreadsheet programs are also used to make out invoices. Look at the invoice below and fill in the blanks with the right words from the box.

Quantity	Description	Price	VAT (Value Added Tax)
Reference	TOTAL	Address	Company

<b>Name:</b> Redwood Comprehensive School		<b>Invoice</b>	
Springbank Road, Easthill		<b>Date:</b> 12 March 2003	
<b>Telephone:</b> 436171			
			<b>Total</b>
Ulysses Classic	256 MB of RAM, 60 GB HD	12	£ 12,600
XGA Monitor	Colour 16"	9	2,025
Video Card	Millions of colours	5	1,580
Portable Ulysses	128 MB RAM, 40 GB HD	3	3,570
Laser SAT	PostScript	1	825
Scanner JUP	Flatbed. Includes OCR	2	1,350
		Subtotal	£ 21,950
		17.5%	3,841
<b>Ulysses Computers, Inc.</b>			£ 25,791

**B** Have you got a spreadsheet program at work or school? If so, try to produce a similar invoice.

# Unit 17 Databases

## 1 Warm-up

Companies often use databases to store information about customers, suppliers and their own personnel. Study the illustrations and then try to answer these questions.

- 1 What is a database?
- 2 Which tasks can be performed by using a database? Make a list of possible applications.
- 3 What do the terms mean in your language: **file**, **record**, **field**?

	<b>Name</b> James Powell <b>Address</b> 12, Back St. <b>Marital status</b> Single
<b>Identification</b> 0994989	<b>Home phone</b> 456367
<b>Job</b> ENGINEER	<b>Department</b> Data processing
<b>SALARY</b> £18,750	<b>Commission</b> £2,785

*Record from an Employee file in a database. This record holds ten fields (the illustration is one)*



**Record 1** Dept:  Commission:

Name:   
Address:   
  
Home phone:

Identification:   
Occupation:  Salary:

*A database file stores information in fields grouped on records*

## 2 Reading

- A** Here is part of an article about databases. First, read all the way through and underline the basic features of a database.

### *Basic features of database programs*

With a **database** you can store, organize and retrieve a large collection of related information on computer. If you like, it is the electronic equivalent of an indexed filing cabinet. Let us look at some features and applications.

● Information is entered on a database via **fields**. Each field holds a separate piece of information, and the fields are collected together into **records**. For example, a record about an employee might consist of several fields which give their name, address, telephone number, age, salary and length of employment with the company. Records are grouped together into **files** which hold large amounts of information. Files can easily be updated: you can always change fields, add new records or delete old ones. With the right database software, you are able to keep track of stock, sales, market trends, orders, invoices and many more details that can make your company successful.

● Another feature of database programs is that you can automatically look up and find records containing particular information. You can also search on more than one field at a time. For example, if a managing director

wanted to know all the customers that spend more than £7,000 per month, the program would search on the name field and the money field simultaneously.

A computer database is much faster to consult and update than a card index system. It occupies a lot less space, and records can be automatically sorted into numerical or alphabetical order using any field.

The best packages also include networking facilities, which add a new dimension of productivity to businesses. For example, managers of different departments can have direct access to a common database, which represents an enormous advantage. Thanks to security devices, you can share part of your files on a network and control who sees the information. Most aspects of the program can be protected by user-defined passwords. For example, if you wanted to share an employee's personal details, but not their commission, you could protect the commission field.

In short, a database manager helps you control the data you have at home, in the library or in your business.

- B** Now make a list of the words you don't understand. Can you guess their meaning? Compare your ideas with other students.

- C** Using the information in the text, complete these statements.

- 1 A database is used to .....
- 2 Information is entered on a database via .....
- 3 Each field holds .....
- 4 'Updating' a file means .....
- 5 The advantages of a database program over a manual filing system are .....
- 6 Access to a common database can be protected by using .....

### 3 Puzzle

Complete the sentences by using a term from the list. Then write the words in the crossword to find the hidden message.

database   field   layout   merging   record   sorted   updated

- In order to personalize a standard letter you can use 'mail .....' (a technique which consists of combining a database with a document made with a word processor).
- Records can be automatically ..... into any order.
- You can decide how many fields you want to have on a .....
- Files can easily be ..... by adding new information or deleting the old one.
- A ..... program can be used to store, organize and retrieve information of any kind.
- The ..... of the records can be designed by the user.
- Each piece of information is given in a separate .....

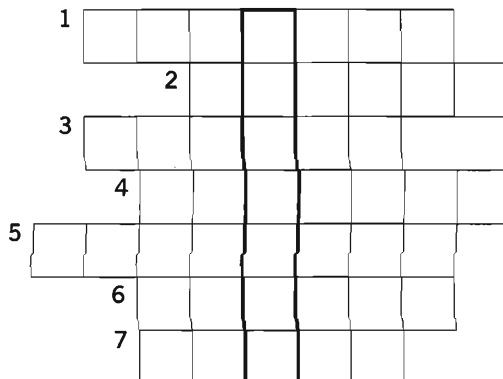

#### HELP box Plurals

- In most cases, the plural in English is written with an 's'.  
*record* → *records*
  - The plural is written with 'es' after 's', 'sh', 'x' or 'ch'.  
*address* → *addresses*   *box* → *boxes*
  - With nouns which end in a consonant + 'y', the 'y' becomes 'i' and 'es' is added.  
*technology* → *technologies*
  - But if the 'y' follows a vowel, only 's' is added.  
*day* → *days*
- Special plural forms
  - man* → *men*
  - child* → *children*
  - analysis* → *analyses*
  - formula* → *formulae/formulas*
- Pronunciation of the 's'.
  - /s/ after one of the sounds /p/, /t/, /k/, /f/ or /θ/  
*chips*, *amounts*
  - /z/ after one of the sounds /s/, /z/, /ʃ/, /tʃ/ or /dʒ/  
*processes*, *cartridges*
  - /z/ in most other cases  
*drives*, *customers*, *files*

### 4 Language work: Plurals

**A** Look at the HELP box and then write the plural of these words:

- |               |          |
|---------------|----------|
| 1 slot        | 5 fax    |
| 2 key         | 6 mouse  |
| 3 directory   | 7 floppy |
| 4 businessman | 8 virus  |

**B** Look at the text again and find five plurals pronounced /ɪz/.

- C**  Put these plurals in the correct pronunciation column. Then listen and check your answers.

passwords	laptops	budgets	images	fields	taxes
graphics	expenses	folders	interfaces	disks	pixels

/s/	/ɪz/	/z/

## 5 Listening

- A**  Listen to Helena Davies, an IT trainer, explaining how to use mail merging to some employees. Number these steps in the order that you hear them.

- Activate the Mail Merge command (Print Merge in some programs). This combines the main document and the data document.
- Click 'Print' and the program generates a single letter for each record in the data document.
- Create the data document with a database program or with the right spreadsheet software. This document contains rows with names, addresses and other information that will be merged with the standard letter.
- Create the main document with a word processor. Type the standard letter and insert the appropriate field names into it.

- B** Look at the illustration of mail merging and identify the three types of documents involved in this example of mail merging.

	A	B	C	D	E	F
1	Title	First name	Last name	Street	City	Postcode
2	Mr	Fred	Jones	15 The Calls	Leeds	LS2 6JU
3	Mrs	Diana	Read	18 Union Street	Glasgow	G1 3TA
4	Ms	Carol	Taylor	75 Windmill Street	London	W1P 1HH
5	Mr	Jack	Gordon	7 Piccadilly Street	York	YO1 1PN

*The data document contains the fields and the information that is different in each version of the letter*

«DATA Mailing»  
 «Title»«First name»«Last name»  
 «Street»  
 «City»«Postcode»

Dear «Title»«Last name»,

We are pleased to inform you that an updated version of Top Project is now available. To obtain your copy, simply call us and we'll send you, absolutely free, the new version of the program.

We also enclose a catalogue with the new range of SunRise machines and the latest software products. There are special offers for all our clients, including a book about budgeting and balancing. To order by phone, call 01332 8430477.

Yours sincerely,

Barry Stephens  
 Sales Manager  
 Sunrise Computers  
 19 Park Avenue  
 Derby

*The main document contains the standard letter*

Mr Fred Jones  
 15 The Calls  
 Leeds LS2 6JU

Dear Mr Jones,  
 We are pleased to in  
 an updated version of  
 now available. To obt  
 simply call us and w  
 absolutely free, the n  
 the program.

We also enclose a c  
 the new range of Sun  
 and the latest softw  
 There are special off  
 clients, including a  
 budgeting and balan  
 by phone, call 01332 :

Yours sincerely,

Barry Stephens  
 Sales Manager  
 Sunrise Computers  
 19 Park Avenue  
 Derby

Mrs Diana Read  
 18 Union Street  
 Glasgow G1 3TA

Dear Mrs Read,  
 We are pleased to infc  
 an updated version of 1  
 now available. To obtai  
 simply call us and we  
 absolutely free, the ne  
 the program.

We also enclose a cat  
 the new range of SunRi  
 and the latest softwa  
 There are special offer  
 clients, including a  
 budgeting and balanci  
 by phone, call 01332 84

Yours sincerely,

Barry Stephens  
 Sales Manager  
 Sunrise Computers  
 19 Park Avenue  
 Derby

Ms Carol Taylor  
 75 Windmill Street  
 London W1P 1HH

Dear Ms Taylor,  
 We are pleased to inform  
 an updated version of To  
 now available. To obtain  
 simply call us and we'll  
 absolutely free, the new  
 the program.

We also enclose a cata  
 the new range of SunRis  
 and the latest software  
 There are special offers  
 clients, including a b  
 budgeting and balanci  
 by phone, call 01332 843

Yours sincerely,

Barry Stephens  
 Sales Manager  
 Sunrise Computers  
 19 Park Avenue  
 Derby

Mr Jack Gordon  
 7 Piccadilly Street  
 York YO1 1PN

Dear Mr Gordon,  
 We are pleased to inform you that  
 an updated version of Top Project is  
 now available. To obtain your copy,  
 simply call us and we'll send you,  
 absolutely free, the new version of  
 the program.

We also enclose a catalogue with  
 the new range of SunRise machines  
 and the latest software products.  
 There are special offers for all our  
 clients, including a book about  
 budgeting and balancing. To order  
 by phone, call 01332 8430477.

Yours sincerely,

Barry Stephens  
 Sales Manager  
 Sunrise Computers  
 19 Park Avenue  
 Derby

*Merging the main document and the data document generates personalized versions of the letter*

## 6 Writing

Imagine that you are Barry Stephens, the sales manager of Sunrise Computers.  
**Write a standard letter to your clients about 'New software products on the market'  
 and offer them a free demonstration disk.**

# Unit 18 *Faces of the Internet*

## 1 Get ready for listening

Try to answer these questions.

- 1 What is the Internet?
- 2 What can you do on the Internet?  
Make a list of possible applications.

*A program like Microsoft Internet Explorer allows you to search, view and manage information over the Web.  
<http://www.microsoft.com/windows/te/>*

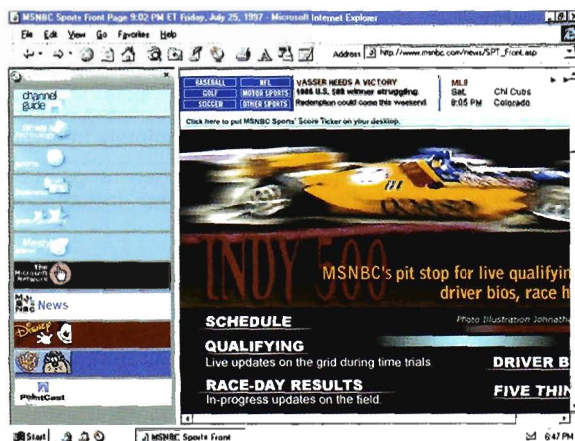

## 2 Listening

 Peter Morgan, the director of Text Link, is talking to a journalist about the Internet. Listen and complete the journalist's notes.

- To connect to the Internet you need:  
(1) ..... (2) ..... (3) .....
- One cable of the modem is connected to the (4) ..... of your computer and the other to the (5) .....
- To get your Internet identity you need to have an account with a (6) ....., a company that offers connection for an annual fee.
- Services offered by the Internet: (7) ..... (10) .....  
(8) ..... (11) .....  
(9) .....
- The Web is a huge collection of (12) ..... stored on computers all over the world.

## 3 Reading

**A** Which Internet utility (1 to 7) would you use to do each of these tasks (a to g)?  
Read the text on page 83 to check your answers.

- |                     |                                                                                        |
|---------------------|----------------------------------------------------------------------------------------|
| 1 e-mail            | a send a message to another person via the Internet                                    |
| 2 Web browser       | b transfer files from the Internet to your hard disk                                   |
| 3 Newsreader        | c have a live conversation (usually typed) on the Internet                             |
| 4 IRC/chat program  | d connect to a remote computer by entering certain instructions and run programs on it |
| 5 FTP software      | e take part in public discussion areas, called newsgroups                              |
| 6 Videoconferencing | f fetch and view Web pages on the Internet                                             |
| 7 Telnet            | g participate in live conversations, using text, audio and video                       |

## Internet software

### Getting connected

The language used for data transfer on the Internet is known as TCP/IP (transmission control protocol/Internet protocol). This is like the Internet operating system.

The first program you need is a PPP (point to point protocol) driver. This piece of software allows the TCP/IP system to work with your modem; it dials up your Internet service provider (ISP), transmits your password and log-in name and allows Internet programs to operate.

### E-mail

E-mail is your personal connection to the Internet. It allows you to exchange messages with people all over the world. It can include text, pictures, and even audio and animation.

When you set up an account with an ISP, you are given a unique address and anyone can send you e-mail. The mail you receive is stored on the server of your ISP until you next connect and download it to your hard disk.

### Web browsers

The Web is a hypertext-based system where you can find news, pictures, games, online shopping, virtual museums, electronic magazines – any topic you can imagine.

You navigate through the Web using a program called a 'browser', which allows you to search and print Web pages. You can also click on keywords or buttons that take you to other destinations on the net. This is possible because browsers understand hypertext markup language (HTML), a set of commands that indicate how a Web page is formatted and displayed.

### IRC, audio and video chatting

IRC – *Internet relay chat* – is a system for real-time (usually typed) conversation. It's easy to use. To start a chat session you run an IRC program, which connects you to an IRC server – a computer dedicated to IRC. Then you join a channel, which connects you to a single chat

area. Next you type a message and the other participants can see it.

Internet telephone and video chatting are based on IRC protocols. Videoconferencing programs enable users to talk to and see each other, and collaborate. They are used in intranets – company networks that use Internet software but make their Web site accessible only to employees and authorized users.



*A videoconferencing system combines data, voice and video.*

### FTP and Telnet

With **FTP** software you can copy programs, games, images and sounds from the hard disk of a remote computer to your hard disk. Today this utility is built into Web browsers.

A **Telnet** program is used to log directly into remote computer systems. This enables you to run programs kept on them and edit files directly.

### Newsgroups

Newsgroups are the public discussion areas which make up a system called 'Usenet'. The contents of the newsgroups are contributed by people who send articles (messages) or respond to articles. They are classified into categories: *comp* (computers), *misc* (miscellaneous), *news* (news), *rec* (recreation), *soc* (society), *sci* (science), *talk* and *alt* (alternative).

**B Read the text again and choose the right answer.**

- 1 An Internet service provider (ISP) is
  - a a program that connects you to the Internet.
  - b a company that gives you access to the Internet.
- 2 HTML is
  - a the software which allows you to fetch and see Web pages.
  - b the codes used to create hypertext documents for the Web.
- 3 An IRC channel is
  - a an IRC discussion area.
  - b a computer system dedicated to IRC.
- 4 Usenet is
  - a a big system of public discussion groups.
  - b a newsgroup.
- 5 An intranet is
  - a like a small version of the Internet inside a company.
  - b a commercial online service.

## 4 Speaking

**A Ask your partner these questions.**

- 1 What web site do you visit to chat with friends?
- 2 Which chat channels are you interested in?
- 3 Do you talk with strangers during web chats?
- 4 Do you use your real name or a nickname?
- 5 How long do you usually spend at the terminal?

**B Imagine you are taking part in an IRC session with a friend. Complete the dialogue. Then act out the conversation.**

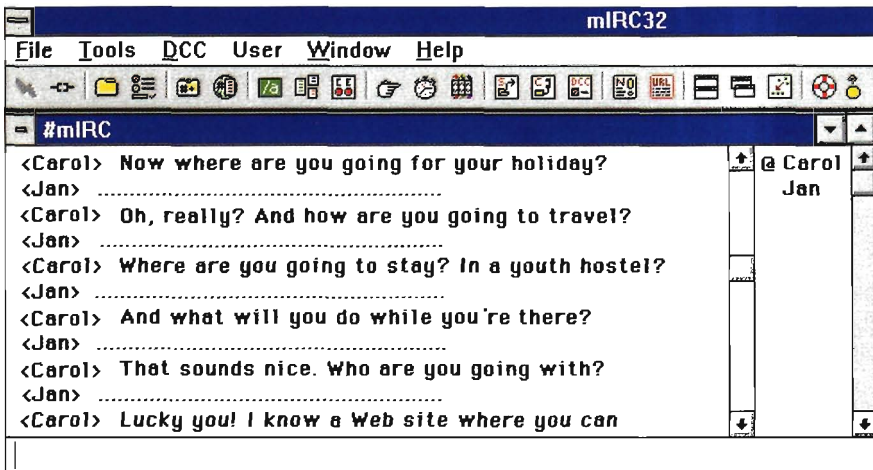

*mIRC for Windows is a typical Internet relay chat program.  
You can get it at <http://www.mirc.co.uk/>*

## 5 A typical web page

**A** The picture below illustrates a typical web page. Look at the **HELP box** and then find the following features in the picture:

- 1 URL address
- 2 Basic functions of the toolbar:
  - a go to the home page
  - b retrace your steps
  - c go forward one page
  - d interrupt the current transfer
  - e update a page
  - f find words within a page
  - g load and display the page's images
- 3 Clickable image link
- 4 Clickable hypertext link

### HELP box

- **URL:** uniform resource locator, the address of a file on the Internet. A URL looks like this:  
**http://www.netscape.com/**
  - 'http://' means hypertext transfer protocol and tells the program to look for a web page
  - 'www' means World Wide Web
  - 'netscape.com' is the domain name and tells people that it is a commercial enterprise
- **navigation buttons:** buttons on the toolbar which allow you to go back or forward to other web pages. You can also return to your start-up page or stop the transfer when the circuits are busy
- **links:** shortcuts (underlined text or images) that, when clicked, take you to other web pages
- **security on the Web:** just a few websites are secure. When the page is not encrypted, the security lock is open



*A sample screen from Netscape Communicator, a leading program for work on the Internet.  
<http://www.netscape.com/>*

**B** Have you ever surfed the Web? What are your favourite web sites? Tell your partner about it.

**C Look at these tasks and choose the most suitable Web site from the cyberlist.**

- 1 Read about environmental problems
- 2 Get news reports
- 3 Find out about specific hardware and software
- 4 Make flight reservations
- 5 Read about films and Hollywood awards
- 6 Search for web addresses

<http://www.yahoo.com/>  
<http://www.greenpeace.org/>  
<http://www.ibm.com/>  
<http://www.gofly.com/>  
<http://www.telegraph.co.uk/>  
<http://www.oscars.org/>

## 6 Writing

**A Study the format of the Internet address. Then read the header of the e-mail below and identify the sender, the recipient and the line that describes the content. Is there an attached file? How do you say 'attachment' in your language?**

**B Write a reply to the e-mail message.**

**The format of an e-mail address:**

**celia@mail.sendanet.es**

- User name or nickname
- The @ sign means 'at'
- The computer system where the user gets e-mail. 'Sendanet' is an Internet service provider.
- Tells people that the company is based in Spain. Other countries include .fr for France, .nl for Holland, .uk for United Kingdom, etc.

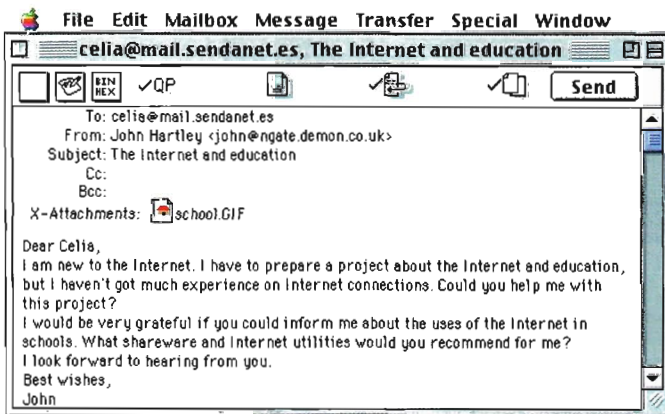

*A sample screen from Eudora, a popular e-mail program. Qualcomm's Eudora is available at <http://www.eudora.com/>*



Enter the Infotech website at [www.cambridge.org/elt/infotech](http://www.cambridge.org/elt/infotech)

Then go to the Web links section and do the activity History of the Internet

# Creative software

Unit		page
19	<i>Graphics and design</i>	88
20	<i>Desktop publishing</i>	93
21	<i>Web design</i>	97
22	<i>Multimedia</i>	101

## Learning objectives

***In this section you will learn how to:***

- identify the functions of different graphics tools
- understand specific aspects of desktop publishing, web design and multimedia applications
- write a letter to a newspaper asking for information about the hardware and page-layout software used for its production
- describe the process of making a movie on the computer
- use certain grammatical structures: *-ing* nouns, modal verbs, *if* clauses
- build up new words by using prefixes, suffixes and compounds
- acquire the basic vocabulary associated with graphical representations, desktop publishing and multimedia technology.

# Unit 19 *Graphics and design*

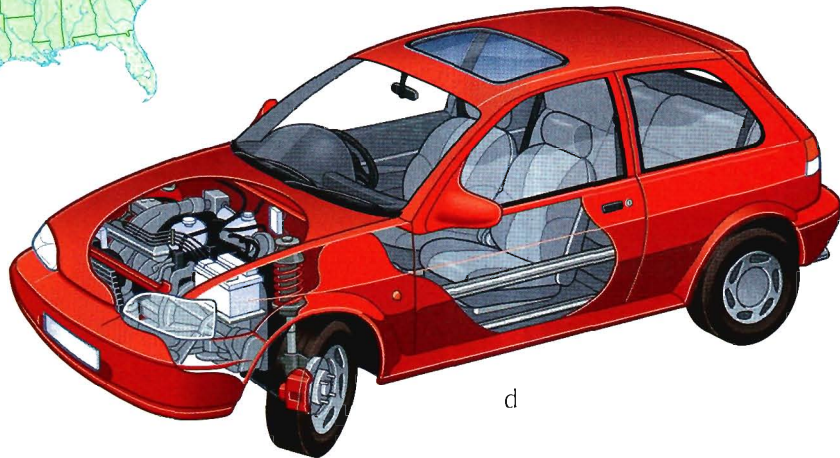
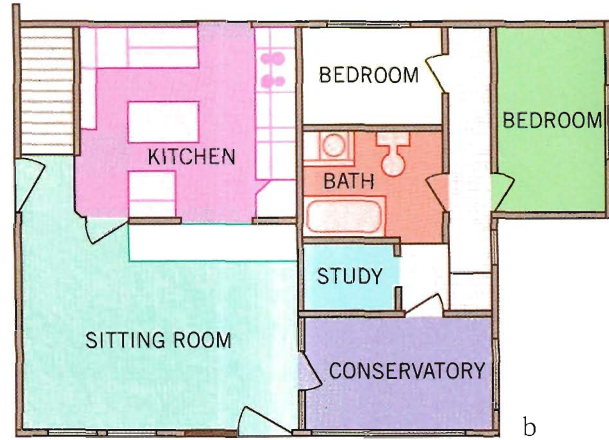
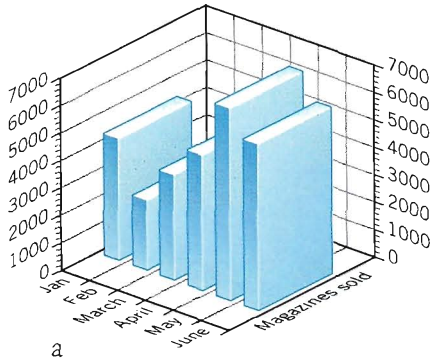

## 1 Warm-up

- 1 Look at the pictures above, which were all created on computer. Which ones are three-dimensional? What are the advantages of creating three-dimensional images?
- 2 From the pictures, can you suggest which people might use computer graphics professionally? What would they use them for?
- 3 Can you think of other professionals who use computer graphics? How do they use them?

## 2 Reading

Read through the text and find the answers to these questions.

- 1 What are 'computer graphics'?
- 2 What do the acronyms 'CAD', 'CAE' and 'CAM' stand for?
- 3 What are the benefits of using computer graphics in the car industry?
- 4 What are the benefits of using graphics in business?
- 5 What is 'computer animation'?

### Computer graphics

Computer graphics are pictures and drawings produced by computer. A graphics program interprets the input provided by the user and transforms it into images that can be displayed on the screen, printed on paper or transferred to microfilm. In the process the computer uses hundreds of mathematical formulas to convert the bits of data into precise shapes and colours. Graphics can be developed for a variety of uses including presentations, desktop publishing, illustrations, architectural designs and detailed engineering drawings.

Mechanical engineers use sophisticated programs for applications in computer-aided design and computer-aided manufacturing. Let us take, for example, the car industry. CAD software is used to develop, model and test car designs before the actual parts are made. This can save a lot of time and money.

Computers are also used to present data in a

more understandable form: electrical engineers use computer graphics to design circuits and people in business can present information visually to clients in graphs and diagrams. These are much more effective ways of communicating than lists of figures or long explanations.

Today, three-dimensional graphics, along with colour and animation, are essential for such applications as fine art, graphic design, Web-page design, computer-aided engineering and academic research. Computer animation is the process of creating objects and pictures which move across the screen; it is used by scientists and engineers to analyse problems. With the appropriate software they can study the structure of objects and how it is affected by particular changes.

Basically, computer graphics help users to understand complex information quickly by presenting it in a clear visual form.

## 3 Listening

A  Read the passage below and complete it. Then listen and check your answers.

### A basic tool palette

A graphics (1) p..... is the software that enables you to draw and manipulate objects on a computer. Each graphics package has its own facilities, plus a wide range of basic drawing and (2) p..... tools. The collection of tools in a package is known as a palette.

The basic shapes which are used to make (3) g..... objects are called 'primitives'. These are usually geometric, such as lines between two points, arcs, (4) c....., polygons, ellipses and even text. You can choose both the primitive you want and where it should go on the screen. Moreover, you can specify the (5) 'a.....' of each primitive, such as its colour, (6) l..... type, fill area, interior style and so on.

The various tools in a palette usually appear together as pop-up (7) i..... in a menu. To use one you activate it by (8) c..... on it. For example, if you want to draw a rectangle, you activate the rectangle tool and the pop-up options allow you to choose the origin of the rectangle (using the insertion point as its centre or corner) and the possibility of (9) d..... a rectangle with rounded corners.

**B Look at the functions represented by the icons in the tool palette on the left and match them with the definitions on the right.**

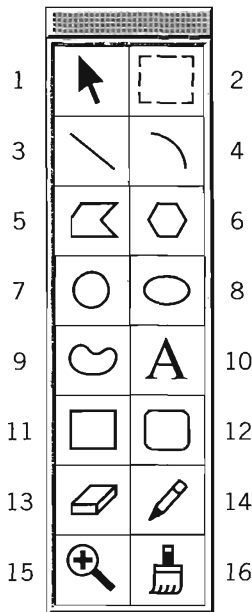

- a This is used to scale the view. Similar to the command 'Zoom in/out'.
- b This is used to delete the part of the picture you drag it over. It is known as 'Eraser'.
- c This is used to type text.
- d This draws a straight line between two points.
- e This is a paintbrush used to add colour and patterns. It often comes in different shapes.
- f This is used to draw polygons with irregular sides.
- g This is used to draw thin, free-form lines.
- h These are used to select text and images.
- i This draws an arc, or part of a circle.
- j This draws curved, free-form shapes.
- k This is used to draw a circle with two foci, known as an ellipse.
- l These two are used to draw all kinds of rectangles, even ones with rounded corners.
- m This is used to draw a circle.
- n This is used to draw polygons with equal sides.

## 4 More about graphics

**A Graphics programs have several options that work in conjunction with the tools menu to enable the user to manipulate and change pictures.**

Look at the facilities on the left and match them with the definitions on the right.

- 1 Patterns menu
  - 2 Scaling
  - 3 Rotating
  - 4 Inverting
  - 5 Zoom
  - 6 Slanting
  - 7 Black-and-white dithering
- a Turning an image round.
  - b A tool which lets you scale the 'view' of a picture and edit a small portion of it as if you were working under a magnifying glass. It is very useful for doing detailed work as you can edit the picture one dot at a time.
  - c Making the object larger or smaller in any of the horizontal, vertical or depth directions.
  - d A shading technique where two different colours are placed next to each other; the human eye blends the colours to form a third one. It is also used to show shading in black and white.
  - e A palette from which you choose a design to fill in shapes.
  - f Reversing the colour of the dots in the selected part of a picture, so that white dots become black and black dots become white.
  - g Inclining an object to an oblique position.

**B Look at the pictures and label them with the facility that has been used to change the original.**

Original

1.....

2.....

3.....

4.....

5.....

6.....

7.....

## 5 Language work: Gerunds (-ing nouns)

- A** Read the passage below, then look at the HELP box. Underline the gerunds and decide whether they function as the subject, the subject complement, the object of a verb, or the object of a preposition.

5 You cannot create a picture simply by specifying primitives. Instead, you must specify the primitives and their attributes, then transform them by specifying where and how you want them placed on the screen so they create your picture. Transformation means moving or otherwise manipulating the object by translating, rotating and scaling the object. Translation is moving an object along an axis to somewhere else in the viewing area. Rotation is turning the object around an axis. Scaling is making the object larger or smaller in any of the horizontal, vertical or depth directions (corresponding to the x, y and z axes). The term rendering describes the techniques used to make your object look real. Rendering includes hidden surface removal, shading, light sources and reflections.

(from *Introduction to Computer Graphics*, ©Hewlett-Packard Limited, 1989)

- B** Complete the sentences by using an appropriate gerund from those in the box.

creating    adding    clicking  
processing    printing    rendering

- 1 Graphic artists like ..... colour and depth to their drawings and designs.
- 2 A 32-bit painting program has a complete palette of tools for ..... images from scratch.
- 3 The speed of a microprocessor is important in ..... information.
- 4 Before ..... a document, the user should decide on the layout.
- 5 You can open the colour palette by ..... on the corresponding pop-up icon.
- 6 ..... refers to the techniques used to make realistic images.

*Rendering shows differences in light and shade*

### HELP box Gerunds

Gerunds are nouns formed by adding *-ing* to verbs. A gerund usually functions as:

- the subject of a verb, e.g. *Smoking is bad for your health.*
- the object of a verb, e.g. *She has never done any computing.*
- the object of a preposition, e.g. *CAD programs are very fast at performing drawing functions.*
- the complement of the subject, e.g. *His favourite pastime is playing computer games.*

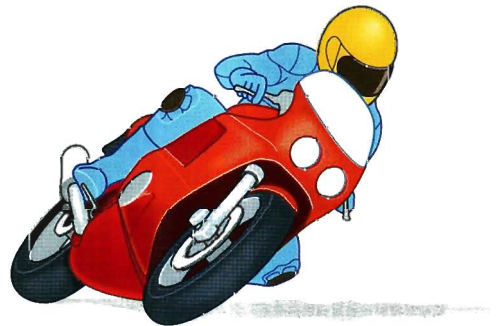

## 6 Speaking

Work in pairs. Student A: turn to page 143 and Student B: turn to page 147.

# Unit 20 *Desktop publishing*

## 1 Warm-up

Look at the illustration below and, with a partner, write down some answers to these questions.

- 1 What types of files are combined in desktop publishing?
- 2 What kinds of documents can be produced with desktop publishing software?

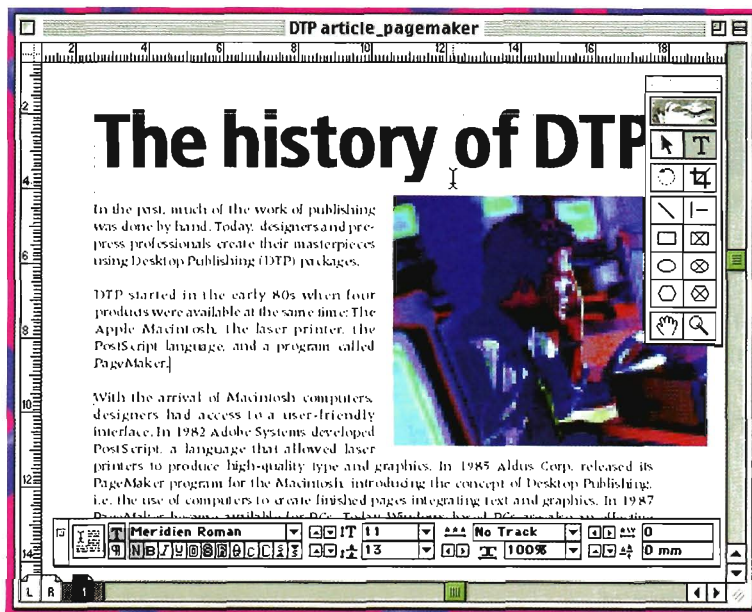

A screen from PageMaker, a leading DTP package. Another program often associated with DTP is QuarkXPress.

## 2 Reading

A Read the text and check your answers to Task 1.

### *What is 'desktop publishing'?*

'Desktop publishing' refers to the use of personal computers to design, implement and publish books, newsletters, magazines and other printed pieces. Desktop publishing is really a combination of a few different processes including word processors, graphic design, information design, output and pre-

press technologies, and sometimes image manipulation. There are also many applications that support these processes, including font creation applications (that allow users to design and create their own typefaces, called fonts) and type manipulation applications (that allow users to modify text in visually creative ways).

15 Desktop publishing centres around a **layout application**. A layout application is used to import text from word processing applications, graphics from paint and drawing applications and images from scanning or image manipulation applications, and to combine and arrange them all on a page. They typically can bring in or import many different types of files. It is this ability to manipulate so many different items and control how they are used that makes layout software so popular and useful. This software is usually the last stop before a document is printed. Once composed and

designed, these files can be printed onto film by high quality devices, called **imagesetters**, and printed on a traditional printing press.

Because imagesetters are expensive devices, most people cannot afford to buy their own. There are, however, companies called **service bureaux** that specialize in printing other people's files on imagesetters, just like copy stores make copiers available to others. Service bureaux can offer imageset output, laser printer output, colour laser printer output and even slide or film recorder output. In addition, some have colour scanning equipment.

(Adapted from *Understanding Computers*, N. Shedroff *et al.* Sybex, 1993)

**B Read the text again and complete these sentences.**

- 1 A page layout application can import and combine .....
- 2 Font creation software enables users to .....
- 3 Imagesetters are used to .....
- 4 Service bureaux offer services such as .....

### 3 Word building

Look at the HELP box which lists ways of forming new words in English. Then in pairs, look at these words and decide:

- which process of word formation has been applied
- what part of speech each word is
- where the stress falls in each word. Underline the stressed syllable(s).

- |                  |                 |
|------------------|-----------------|
| 1 upgrade        | 9 manipulation  |
| 2 imprint        | 10 publishing   |
| 3 printed        | 11 publisher    |
| 4 print-out      | 12 newsletter   |
| 5 interactive    | 13 visually     |
| 6 printing press | 14 typeface     |
| 7 pre-press      | 15 professional |
| 8 creative       | 16 imagesetter  |

**HELP box**  
**Word formation**

New words are formed in three main ways in English:

1 Affixation

- adding a prefix to the base:  
*print* → *reprint*
- adding a suffix to the base:  
*print* → *printer*

2 Conversion, i.e. assigning one class to another:

*print* v → *print* n

3 Compounding, i.e. adding one base to another:

*finger* + *print* → *fingerprint*

## 4 Listening

 Listen to this radio interview with Ros Jackson about the importance of fonts and typography in desktop publishing and choose the correct answer.

- 1 What does Ms Jackson do?
  - a She's an advertiser.
  - b She's a font software designer.
  - c She's a DTP professional.
- 2 Fonts refer to
  - a the style of a typeface.
  - b the size of a typeface.
  - c the style and size of a typeface, for example **Helvetica italic in 12 point.**
- 3 According to Ms Jackson, fonts and other type characteristics
  - a don't make any difference to a message.
  - b are important in order to communicate a message clearly and make it look attractive.
  - c help designers scale and rotate type and text.
- 4 Scalable fonts are stored as
  - a a whole image made up of dots, which cannot be changed.
  - b an outline which can be changed.
- 5 PostScript fonts were created by
  - a Apple and Microsoft.
  - b Adobe Systems.

Bookman at 12pt

Courier

Σψμβολ (Symbol)

❖❖❖❖❖❖❖❖ (Zapf Dingbats)

Palatino

Helvetica Italic

**Times Bold Italic**

Zapf Chancery

Chicago at 12pt

**Chicago by night**

**Blackoak**

Old Dreadful 10.7

Orbit-B

PIONEER

**SHOTGUN**

DIGITAL

# 5 Computers for newspapers

**A** The letter below is from a group of students asking for information about the hardware and publishing software used by the newspaper *El Independiente*.

Read it and note:

- the form and position of the addresses
- the polite forms of asking for cooperation:
  - *We would be very grateful if you could ...*
  - *Could you also ...*
- the ways in which the letter begins and ends.

**B** Work in pairs. Student A: turn to page 144 and Student B: turn to page 148.

**C** Write a letter to the *Morning News* asking for information about the hardware and page-layout software used in its production. Use the letter on the right to help you.

**Rhondda**  
**Comprehensive School**  
 31 Prospect Place, Treorchy, Wales

The Editor  
 El Independiente  
 c/ Moratin, 7  
 28006 Madrid  
 Spain

28th August 2002

Dear Sir/Madam

We are writing to ask if you can help us with our school project. We are doing a survey of the major newspapers in the European Union to find out which computer systems and desktop publishing programs they use.

We would be very grateful if you could tell us which hardware and software you use at *El Independiente*. Could you also tell us whether you have a Web edition published on the Internet? Thank you very much.

We look forward to hearing from you.

Yours faithfully,

Katherine Powell  
 Katherine Powell  
 Student representative

The Editor  
 Morning News  
 14 Pennington Street  
 London EC1 6XJ

Your address

.....  
 .....  
 .....

Date.....

# Unit 21 Web design

## 1 Warm-up

Look at the homepage of Yahoo and try to answer these questions

- 1 Why do people create and publish web pages?
- 2 What does a website consist of?
- 3 What is a homepage?
- 4 What is an Internet portal?



You can use a search engine like Yahoo to find information. It also acts as a web portal offering services such as e-mail, forums, on-line shopping and links to other sites. Specialist portals are related to particular subjects such as music, sports or news.

## 2 Reading

**A** Look at the text and illustrations on the next page and find the answers to these questions.

- 1 What are HTML codes called?
- 2 What's the function of HTML codes?
- 3 What type of program allows you to design a web page without writing HTML?
- 4 How can you view the source code of any web page?
- 5 How do you connect your home page with the other pages that you have created?

Can you recognize these basic HTML tags? Match them with the correct function.

- |                                      |                                                                                                         |
|--------------------------------------|---------------------------------------------------------------------------------------------------------|
| 1 <HTML> </HTML>                     | a) This creates a window with a black background.                                                       |
| 2 <BODY> </BODY>                     | b) These tell your web browser that the file contains information coded with HyperText Markup Language. |
| 3 <H1> </H1>                         | c) This is used to include an inline image.                                                             |
| 4 <HR>                               | d) This tag indicates a new paragraph.                                                                  |
| 5 <IMG SRC="Image filename">         | e) This part contains the content of your document.                                                     |
| 6 <I> </I>                           | f) This tag inserts a horizontal line or rule.                                                          |
| 7 <A HREF="filename">active text</A> | g) This is the most prominent level of headings.                                                        |
| 8 <BODY BGCOLOR="#000000">           | h) This indicates a numbered list (also called an ordered list).                                        |
| 9 <OL>                               | i) These enclose italic text.                                                                           |
| 10 <P>                               | j) This adds a link to another web page.                                                                |

## Creating web pages

You can create a basic web page using a text editor or a word processor, but you need to know a code called HTML, or Hypertext Mark-up Language. This consists of HTML commands, called tags, which are placed around pieces of text to tell the web browser how to display text or graphics. You can enter different commands to define text size and font, format paragraphs, add colour, etc. (See below "studentweb.htm")

All HTML files:

- start with `<HTML>`
- have heading text that begins with `<HEAD>`, which has a title enclosed between tags, and ends with `</HEAD>`
- have body text that starts with `<BODY>`, where you place the contents of the actual document (i.e. text, images, links, etc.), and ends with `</BODY>`
- end with `</HTML>`

You can also create links to other web pages by using the tag `<A HREF="filename">active text</A>`

If you are not familiar with HTML, you can use a Web editor like Microsoft FrontPage or Macromedia Dreamweaver to simplify the process. Web editors are user-friendly and WYSIWYG (What you see is what you get). Different buttons and menu items enable you to design a page without writing HTML, i.e. they automatically produce the tags for text, tables, image maps, frames, etc. You can view the source code for any page you like by clicking the option "Page source" in the browser's menu.

Websites with an effective use of graphics are more inviting and communicative than plain text. So you may like to insert different types of pictures: scanned photos, bars, icons, backgrounds, and moving images.

Once you have created a few pages, you should join them together with hyperlinks. A hyperlink is a piece of highlighted text or a picture that acts as a link to another page. You can place local links to help readers navigate through your pages. You may also like to insert external links to other people's websites.

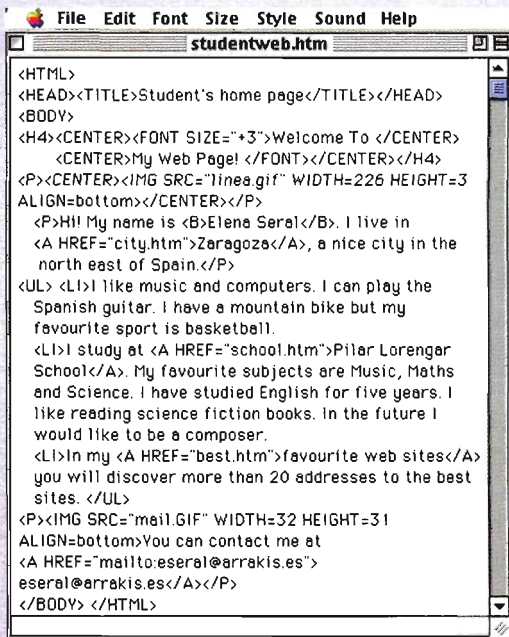

```

File Edit Font Size Style Sound Help
studentweb.htm
<HTML>
<HEAD><TITLE>Student's home page</TITLE></HEAD>
<BODY>
<H4><CENTER><FONT SIZE="+3">Welcome To </CENTER>
<CENTER>My Web Page! </FONT></CENTER></H4>
<P><CENTER><IMG SRC="linea.gif" WIDTH=226 HEIGHT=3
ALIGN=bottom</CENTER></P>
<P>Hi! My name is <B>Elena Seral</B>. I live in
<A HREF="city.htm">Zaragoza</A>, a nice city in the
north east of Spain.</P>
<UL> <LI>I like music and computers. I can play the
Spanish guitar. I have a mountain bike but my
favourite sport is basketball.
<LI>I study at <A HREF="school.htm">Pilar Lorengar
School</A>. My favourite subjects are Music, Maths
and Science. I have studied English for five years. I
like reading science fiction books. In the future I
would like to be a composer.
<LI>In my <A HREF="best.htm">favourite web sites</A>
you will discover more than 20 addresses to the best
sites. </UL>
<P><IMG SRC="mail.GIF" WIDTH=32 HEIGHT=31
ALIGN=bottom>You can contact me at
<A HREF="mailto:eseral@arrakis.es">
eseral@arrakis.es</A></P>
</BODY> </HTML>
  
```

HTML source code

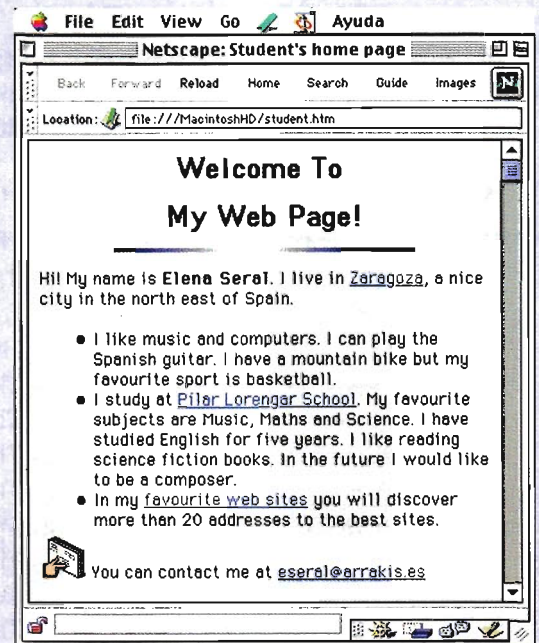

HTML file displayed as a Web page

## 3 Language work: Modal Verbs

**A** Look at the **HELP** box. Then go to the text in Task 2 and underline the modal verbs.

**B** Complete the sentences using *can, could, may, might, should, can't, must*.

- All HTML documents ..... start with <HTML> and end with </HTML>.
- If I knew the Java language, I ..... include some attractive banners on my web page.
- With a web page editor you ..... create a web document easily.
- That woman speaks with a New York accent, so she ..... from the USA.
- She ..... a top model. I know some of her friends.
- He ..... be a good web page designer because he doesn't know the HTML language.
- ..... I use your laptop? I need to print out this report.
- Before you start to make a website, you ..... decide how to organize the content.

### HELP box

**Modal verbs** are followed by infinitive without *to*. They add extra meaning to the main verb.

● **CAN**

Theoretical possibility: *You can add graphics to your web pages.*

Permission: *Can I use your mobile phone?*

Ability: *He can draw very well.*

● **COULD**

Possibility or ability in hypothetical situations: *We could buy a DVD, if you had more money.*

Permission: *Could I just interrupt a minute?*

● **MAY**

Factual possibility: *He may like to talk about e-commerce.*

Permission: *May I use the fax now?*

In this case MAY is more formal than CAN.

● **MIGHT**

Weak possibility: *The prices of CPUs might go down next month.*

● **MUST**

Obligation: *If you suspect an e-mail has a virus, you must delete it without opening.*

Prohibition: *You mustn't open e-mail attachments from strangers.*

Logical necessity: *This looks wrong – there must be a mistake.*

We use CAN'T to express a negative conclusion.

● **SHOULD**

Advice: *You should update your web site.*

## 4 Listening

**A** Think about your favourite websites.

- Do you like the way they are designed? Explain why.
- What elements do you think a good website should have? Make a list.

**B**  In this interview, Sarah Almy describes how to plan, design and publish a website. Listen and put these steps in the correct order.

- Write and format the text
- Decide the content and structure for the website
- Publish the website
- Insert computer graphics and sounds
- Keep website updated
- Weave together related pages with hyperlinks

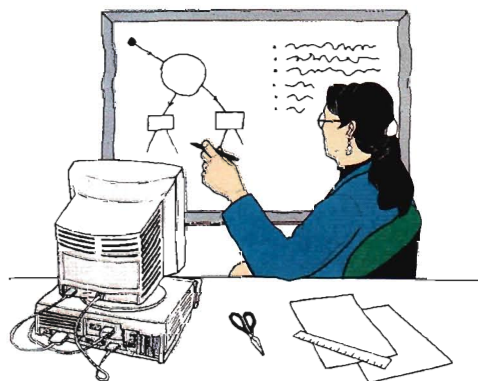

**C**  Listen again and decide whether these design tips (or guidelines) are Right or Wrong.

- |                                                                       |                          |                          |
|-----------------------------------------------------------------------|--------------------------|--------------------------|
|                                                                       | ✓                        | ✗                        |
| 1 Plan your website carefully.                                        | <input type="checkbox"/> | <input type="checkbox"/> |
| 2 Use a Web editor. It will make it easier to create your pages.      | <input type="checkbox"/> | <input type="checkbox"/> |
| 3 Insert photos or animations just to make the pages look attractive. | <input type="checkbox"/> | <input type="checkbox"/> |
| 4 Place a large number of graphics on your pages.                     | <input type="checkbox"/> | <input type="checkbox"/> |
| 5 Use very bright colours.                                            | <input type="checkbox"/> | <input type="checkbox"/> |
| 6 Put a lot of links on one page.                                     | <input type="checkbox"/> | <input type="checkbox"/> |
| 7 Check that all the links on your Web pages are correct.             | <input type="checkbox"/> | <input type="checkbox"/> |
| 8 Once they are published, update your pages regularly.               | <input type="checkbox"/> | <input type="checkbox"/> |

## 5 Speaking

Work through this questionnaire with a partner.

- 1 What do you use the Web for?
- 2 What is your favourite search engine? Why?
- 3 Music portals have become very popular on the Net. Which one do you like most? Why?
- 4 Would you be interested in accessing the Internet through your TV?
- 5 Do you know how to use the HTML language?
- 6 Have you ever used a web editor to create web pages?
- 7 What sort of web pages would you like to make?
- 8 Is there anything you'd like to have on the Internet that you can't have yet?

## 6 Creating basic web pages

**A** Create your own web page. You can use the page in Task 2 as a model.

**B** In small groups, collect information about your college or company and design a web homepage for it.

You can use the document on the right as a model.



Enter the Infotech website at [www.cambridge.org/elt/infotech](http://www.cambridge.org/elt/infotech)

Then go to the [Web links](#) section and do the activity [10 things you can do on the Net](#)

Hello!

Welcome to our web page.

We are 18 students in class.

Here is a picture of my classroom:



We have created a [virtual classroom](#) where each student has written his/her own web page. This is our timetable for this year:

Monday	Tuesday	Wednesday	Thursday	Friday
Computer science	English	French	Graphics & Design	DTP
English	Maths	Graphics & Design	DTP	French
Break time				
Graphics & Design	DTP	Maths	Laboratory	Technical E
French	Sports	Computer science	Technical E.	Tutorial
Break time				
Laboratory	Computer science	Technical E.	Maths	Laboratory

We love English. In class we talk and read texts. We have some friends abroad, so we write letters and e-mails to them. We sometimes go to the library and do [projects](#) on the Web.

 This year we are taking part in a student exchange with England. We are going to [Dereham College](#) in April. We are staying with host families and the English students are coming to our country in May. The program of activities includes excursions to Norwich, Cambridge and London. We are also visiting a printing press and a science museum. We'll have a great time!

# Unit 22 *Multimedia*

## 1 Multimedia is here!

Look at the cover for Encarta.  
What types of data are integrated  
in multimedia applications?

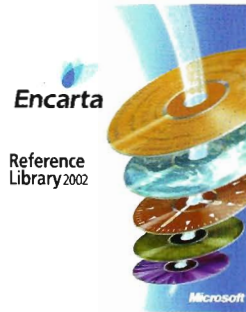

## 2 Listening

A A sales assistant is explaining the components of a multimedia system to a customer. Listen and complete this diagram.

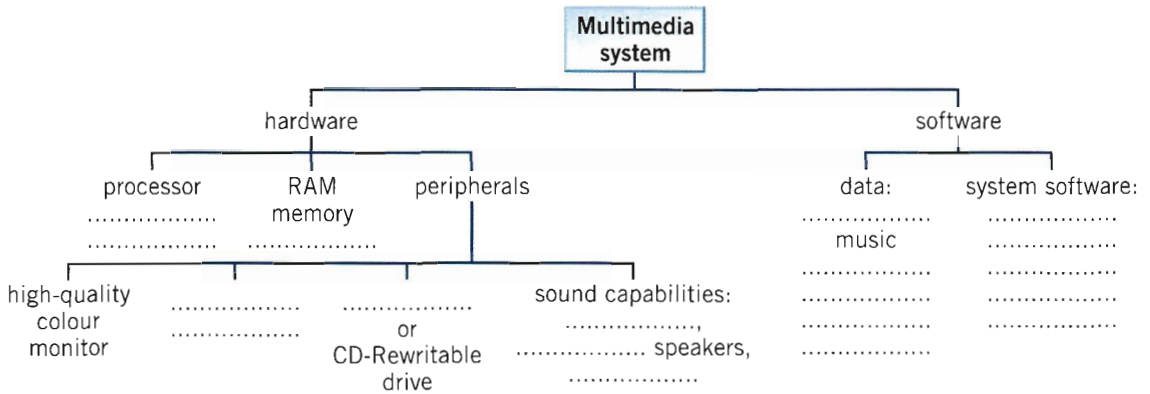

*Compare your answers with another student.*

B Now listen again and answer these questions.

- 1 What is multimedia?
- 2 What is the advantage of computer multimedia presentations over TV and video?
- 3 Which system software is designed by Apple for multimedia work?
  - a Windows with Multimedia control panels
  - b QuickTime

## 3 Reading

A Read the texts and match them with the headings in the box on the next page.

- Sound, Music, MIDI
- CDs and DVDs full of pictures, action and sound!
- Editing photos and making movies in a few minutes!
- The potential of using multimedia

## Multimedia magic!

1 .....

Multimedia applications are used in all sorts of fields. For example, some museums, banks and estate agents have information kiosks that use multimedia. Companies produce training programmes on optical disks, and marketing managers use presentation packages (e.g. *Microsoft PowerPoint*) to make business presentations. Teachers use multimedia programs to make video projects or to teach subjects such as music and languages. They have all found that moving images, sound and music involve viewers emotionally as well as inform them, and make their message more memorable.

The power of multimedia resides in hypertext and hypermedia. If you click on a hypertext word, you jump to another screen with more information about that subject. Hypermedia is similar, but also works with sound, graphics and video.

2 .....

To capture sounds in digital format and play them back, modern PCs contain a sound card. This is a type of expansion card which offers two important capabilities: (i) a built-in stereo synthesizer and (ii) a system called Musical Instrument Digital Interface, or MIDI. This allows electronic musical instruments to communicate with computers.



Musicians can compose, mix and edit music electronically by connecting a computer to special MIDI instruments

You can also listen to music on your PC. Many radio stations broadcast on the Web using a technique called 'streaming'. This lets you play an audio file in a continuous stream, while it's downloading, before the entire file is transmitted. Sometimes bands transmit concerts on the Web in a process called 'webcast'. To listen to online music you just need a plug-in like *RealPlayer*.

3 .....

There are two ways of storing photos on a computer. The first way is to use a digital camera. Photos are stored in a memory chip and then they're downloaded to the computer. The second way is to scan printed photos by using a scanner. With special software you can repair flaws, add effects and even save your photos on a CD.

Video is another important part of multimedia. Video computing refers to recording, manipulating and storing video in digital format. In fact, today you can make your own movies on your PC. This is what you have to do: First capture images with a digital video camera and then transfer the digital video to your computer. Next, with a video editing program (e.g. *iMovie*) cut your favourite segments, re-sequence the clips and add transitions and other effects. Finally, save your movie on a video CD, a DVD or a videotape. You can also place your work on the Internet.

4 .....

Multimedia software is usually interactive and comes on CD-ROMs or DVDs. For example, the *Compton's Encyclopedia* enables you to read about whales, look at photos of whales, listen to whale songs, and view animated sequences. Similarly, the *Grolier Encyclopedia* lets you read about birds, view pictures of birds, and listen to recordings of their songs.

Other CD-ROMs include games, guides, dictionaries and educational courses about history, science, the human body, cinema, literature and foreign languages.

**B Read the texts again and correct these statements. There is a technical mistake in each of them.**

- 1 Multimedia PCs cannot integrate text with graphics and video.
- 2 You don't need to have a sound board on your PC to hear speech and music.
- 3 Most multimedia software is distributed on magnetic disks.
- 4 Digital cameras store photos in a roll of film.
- 5 There are no language courses available on CD-ROM.

**C Match these terms in the box with the explanations.**

a hypertext    b MIDI interface    c Video editing  
d streaming    e webcast

- 1 The process of manipulating video images.
- 2 A code for the exchange of information between PCs and musical instruments.
- 3 Text with hyperlinks, which take you to other pages.
- 4 A concert or other event that is transmitted over the Web.
- 5 A technique for playing sound and video files as a continuous stream, while they're downloading.

## 4 Language work: *If*-clauses

**A Look at the HELP box and then read these sentences. Identify the tenses used in the *if*-clause and in the main clause.**

- 1 If you upgrade your PC, you'll be able to run multimedia applications.
- 2 If the marketing manager had a multimedia system, she could make more effective presentations.

**B Put the verbs in brackets into the correct form.**

- 1 If I (get) ..... a sound card, I'll be able to create my own music with a MIDI.
- 2 If the system (have) ..... a SuperVGA card, we would obtain a better resolution.
- 3 You won't be able to play CD-ROM disks if you (not have) ..... a CD-ROM drive.
- 4 If you (come) ..... to the annual computer exhibition, you could see the new Macs.
- 5 If I could afford it, I (buy) ..... a Multimedia PC.

### HELP box

#### Conditional clauses

When you want to talk about a possible situation and its consequences, you use a conditional sentence. Here we examine two types of conditionals:

- **First conditional (possible situation)**  
If A happens    B will happen.  
(present simple)    (*will* + verb)  
e.g. *If you **click** on the speaker icon, you'll **get** a piece of dialogue from the movie.*  
In the main clause we can also have a modal (*can*), an imperative, or a present tense verb.
- **Second conditional (unlikely situation)**  
If A happened    B would happen.  
(past simple)    (*would* + verb)  
e.g. *If I **had** the money, I **would** (I'd) **invest** in a multimedia upgrade kit.*  
Other modals (*could*, *should*, *might*) may appear in the main clause.

## 5 Multimedia on the Web

### Read the text and find:

- 1 the function of the extension that is usually added to a file name
- 2 the language used to create the majority of text files on the Web
- 3 the graphics interchange format created by CompuServe to compress images
- 4 the small program (plug-in) that lets you hear audio recordings on the Net
- 5 the most popular video formats
- 6 the format created by the Moving Picture Experts' Group to capture, store and play back movies
- 7 the extension for the files that can be decompressed with a program like *Winzip*.

### Recognizing file formats

Web pages can contain different multimedia elements: text, graphics, sounds, video and animation. To identify the format or type of file, an extension (a three-letter suffix) is usually added to the file name when it's saved on disk.

#### Text



The most common text extensions are **.txt**, **.pdf**, **.doc** and **.htm** (or **.html**). Most of the text files that you find on the Web have the extension **.htm**, created with the hypertext markup language.

#### Graphics



Graphics on the Web can include pictures, photos, paintings, image-maps and buttons. The most common formats are **.gif** (a standard image format developed by CompuServe) and **.jpg** or **.jpeg** (created by the Joint Photographic Experts' Group).

#### Sounds

The Internet is a great place to find and hear hit songs, movie soundtracks and recorded interviews. The most common formats are these:



- **.wav**: wave files can be played with Sound Recorder included with Windows
- **.ra** or **.ram**: RealAudio files can be heard with RealPlayer, a plug-in you can download from the Web.
- **.mp3**: compressed music files that can be played with an MP3 player.

#### Video and animation



You can see cartoons and movie clips on the Web, but you need the appropriate software. Video files are usually stored in: **.avi**, **.mov** and **.mpg** (or **.mpeg**) formats. To view MPEG videos you just need Video for Windows. However, to create high-quality movie clips you need a dedicated MPEG expansion card. You can also find animation and 3-D worlds. The two standard tools to manipulate animated worlds are VRML and Java. To view a virtual animation you need a program like QuickTime VR.

#### Compressed files



When you download files, they're probably compressed. Windows files have a **.zip** extension. Macintosh files usually have a **.sit** extension and are opened with *StuffIt*.

## 6 Writing

Making a movie on a PC refers to recording, manipulating and storing video in digital format. The pictures below represent this process. Write a description of it.

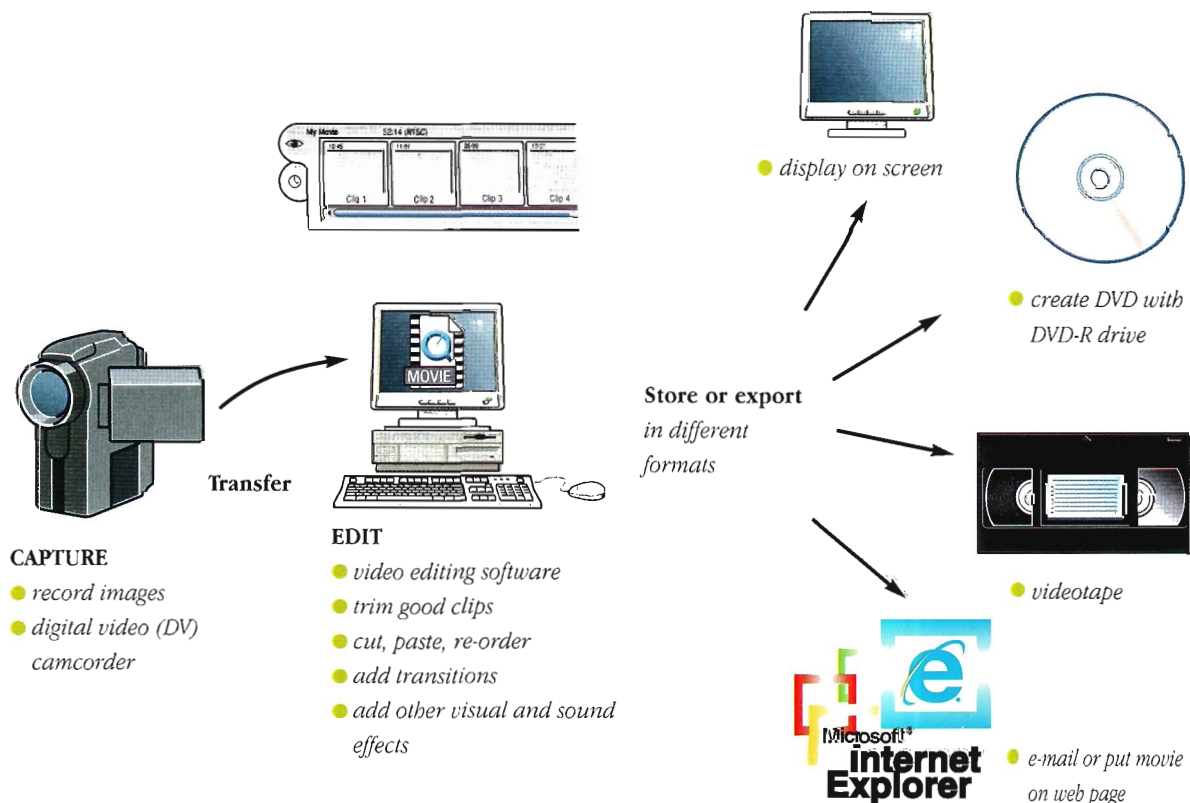

## 7 Listening: Revision of software

 Look at the list of software products and number the items in the order in which you hear them described.

- Graphics and design
- Multimedia application
- DTP
- Database program
- Web editor
- Educational software
- Musical software



Enter the Infotech website at [www.cambridge.org/elt/infotech](http://www.cambridge.org/elt/infotech)

Then go to the Study online section, click on MP3 music and do the activities.

# Programming

Unit	page
23 <i>Program design</i>	107
24 <i>Languages</i>	111
25 <i>The Java revolution</i>	114
26 <i>Jobs in computing</i>	118

## Learning objectives

***In this section you will learn how to:***

- understand basic concepts in programming, and acquire vocabulary connected with it
- recognize acronyms and abbreviations associated with programming
- ask and answer questions about computer languages (Visual BASIC, COBOL, Pascal, SQL, C, Java, VoiceXML)
- discuss the professional skills and personal qualities required for the jobs of senior programmer and DTP operator
- write a letter applying for a job.
- use certain grammatical structures: the passive, the infinitive, the past simple and the present perfect

## 1 Warm-up

**A** In pairs, try to think of an answer for the question:

**What is programming?**

Look at the definition in the Glossary. Is it similar to yours?

**B** Complete the following definitions with the words and phrases in the box.

the various parts of the program    may occur in programs    language  
binary numbers    a given problem

1 **algorithm**

The step-by-step specification of how to reach the solution to .....

2 **flowchart**

A diagram representing the logical sequence between .....

3 **coding**

The translation of the logical steps into a programming .....

4 **machine code**

The basic instructions understood by computers. The processor operates on codes which consist of .....

5 **debugging**

The techniques of detecting, diagnosing and correcting errors (or 'bugs') which .....

## 2 Listening

**A**  Listen to Lucy Boyd, a software developer, explaining how a program is produced. Number these steps in the order you hear them.

- Provide documentation of the program.
- Understand the problem and plan the solution.
- Test and correct the program.
- Make a flowchart of the program.
- Write the instructions in coded form and compile the program.

**B**  Listen again and take notes. Use your notes to explain what each step means.

## 3 Reading

Read the text and find answers to these questions.

- 1 Do computers understand human languages?
- 2 What are the differences between low-level and high-level languages?
- 3 What is an assembler?
- 4 What is the function of compilers?
- 5 What do you understand by the terms **source program** and **object program**?
- 6 In the future, could computers be programmed in Spanish, French or Japanese?

### Programming languages

Unfortunately, computers cannot understand ordinary spoken English or any other natural language. The only language they can understand directly is called **machine code**. This consists of the 1s and 0s (binary codes) that are processed by the CPU.

However, machine code as a means of communication is very difficult to write. For this reason, we use symbolic languages that are easier to understand. Then, by using a special program, these languages can be translated into machine code. For example, the so-called **assembly languages** use abbreviations such as ADD, SUB, MPY to represent instructions. These mnemonic codes are like labels easily associated with the items to which they refer.

Basic languages, where the program is similar to the machine code version, are known as **low-level languages**. In these languages, each instruction is equivalent to a single machine code instruction, and the program is converted into machine code by a special program called an **assembler**. These languages are still quite complex and restricted to particular machines.

To make the programs easier to write and to overcome the problem of intercommunication between different types of machines, higher-level languages were designed such as BASIC, COBOL, FORTRAN or Pascal. These are all problem-oriented rather than machine-oriented. Programs written in one of these languages

(known as **source programs**) are converted into a lower-level language by means of a **compiler** (generating the **object program**). On compilation, each statement in a **high-level language** is generally translated into many machine code instructions.

People communicate instructions to the computer in symbolic languages and the easier this communication can be made, the wider the application of computers will be. Scientists are already working on Artificial Intelligence and the next generation of computers may be able to understand human languages.

Instructions are written  
in a high-level language  
(e.g. Pascal, BASIC, COBOL, Ada, C, Lisp).  
This is known as the source program.

#### Compiler

Compilers translate the  
original code into a  
lower-level language or  
machine code so that the  
CPU can understand it.

Instructions are compiled and packaged  
into a program. The software is ready  
to run on the computer.

## 4 Word building

- A** Look at the groups of words and decide what part of speech each word is. Then complete the sentences with the correct word.

compile    compiler    compilation

- 1 Programs written in a high-level language require ....., or translation into machine code.
- 2 A ..... generates several low-level instructions for each source language statement.
- 3 Programmers usually ..... their programs to create an object program and diagnose possible errors.

program    programmers    programming    programmable

- 4 Most computer ..... make a plan of the program before they write it. This plan is called a flowchart.
- 5 A computer ..... is a set of instructions that tells the computer what to do.
- 6 Converting an algorithm into a sequence of instructions in a programming language is called .....

bug    debug    debugger    debugging

- 7 New programs need ..... to make them work properly.
- 8 Any error or malfunction of a computer program is known as a .....
- 9 The best compilers usually include an integrated ..... which detects syntax errors.

- B** In the word *debug* the prefix *de-* is used. This prefix means 'to reverse an action'. Here are a few more examples:

defrost    debrief    declassify    decode    decompose    decentralize

Write down the base form of each verb. What do the verbs mean in your language? And what do the verbs with *de-* mean?

Can you think of any more verbs with *de-* in English?

## 5 Language work: Infinitive constructions

### A Make sentences as in the example.

#### Example

not easy/write instructions in Pascal

*It is not easy to write instructions in Pascal.*

- 1 advisable/test the program under different conditions
- 2 expensive/set up a data-processing area
- 3 unusual for a program/work correctly the first time it is tested
- 4 difficult for students/learn FORTRAN
- 5 important/consider the capabilities of the programming language
- 6 quite easy/write instructions in BASIC

### B Read the information in the HELP box and then look again at the reading passage in Task 3. Underline the infinitive constructions after modal verbs.

#### Example

Unfortunately, computers cannot understand ordinary spoken English ...

### C Look at these pairs of examples and decide where there is an 'important' change in meaning.

- 1 a I remember shutting down the computer before I left the room.  
b Please remember to buy the new program.
- 2 a They stopped to look at the flowchart.  
b They stopped looking at the flowchart.
- 3 a I like studying C language.  
b I like to study C language in the evenings.
- 4 a It has started to rain.  
b It has started raining.
- 5 a He needs to work harder.  
b This hard disk needs repairing.

#### HELP box

#### Infinitive constructions

The infinitive is used:

- after adjectives  
– *It is **difficult to use** machine code.*
- after modal verbs with *to*: *ought to*, *used to*  
– *I **ought to make** a back-up copy.*  
– *Using a computer is much easier than it **used to be**.*
- after modal and auxiliary verbs without *to*: *can*, *could*, *may*, *might*, *shall*, *should*, *will*, *would*, *would rather*, *would sooner*  
– *Unfortunately, computers **can't understand** English.*  
– *I'd rather **buy** a game than a spreadsheet.*

## 1 Warm-up

- 1 Make a list of as many computer languages as you can think of.
- 2 Do you know any language used to interact with the Internet through voice-recognition?

## 2 The VoiceXML language

Study this table and answer the questions below.

<i>Language</i>	<i>Date</i>	<i>Characteristics</i>	<i>Uses</i>
VXML or VoiceXML (Voice Extensible Markup Language)  Created by a Working Group of four companies – AT & T, Lucent, Motorola and IBM	2000	Based on the XML language.  For input, VoiceXML uses voice recognition. For output, it uses pre-recorded audio content and speech synthesis (text-to-speech).  How do you access a voice web portal? First, you dial its phone number. Then the call is received by a telephone server and the VoiceXML pages are fetched via HTTP. Finally, you get the required information.  A typical VoiceXML page could be 'sports.vxml'.	Used to create voice-user interfaces. Makes Internet content accessible via voice and phone.  Instead of using a web browser on a PC, you use the telephone to access voice-equipped websites via a VoiceXML interpreter (a voice browser).  Applications: – Voice portals (telephone services where you can hear information about sports, news, traffic, etc.) – Voice-enabled intranets – Voice e-commerce – Home appliances controlled by voice.

- 1 What does VXML mean?
- 2 Who created VoiceXML?
- 3 When was it developed?
- 4 What technologies does it use for input and output?
- 5 What are the most suitable applications for VoiceXML?
- 6 What do you think are the benefits of having a voice Web?

### 3 Language work: The passive

**A** Look at the HELP box and then complete these sentences with a suitable verb form.

- 1 COBOL (use) ..... for business applications.
- 2 Original programs (write) ..... in a high-level language.
- 3 All computer languages (must translate) ..... into binary commands.
- 4 The ADA language (develop) ..... in 1979.
- 5 In the 1970s, new languages such as LISP and PROLOG (design) ..... for research into Artificial Intelligence.
- 6 A new version of TurboPascal (release) ..... just .....
- 7 In the next century, computers (program) ..... in natural languages like English or French.

**HELP box**  
**The passive**

The passive is formed with the verb *to be* in the correct tense and the past participle of the main verb.

*Instructions are processed by the CPU.  
The computer was invented by Charles Babbage.*

**B** How do you make the passive in your language?

### 4 Speaking

Work in pairs. Student A: turn to page 145 and Student B: turn to page 149.

### 5 A short description of Visual BASIC

Read the passage and complete it with the verbs in brackets in the correct form.

Visual BASIC is a programming language and an environment (1) (develop) ..... by Microsoft in 1990. It (2) (use) ..... to create applications for Windows operating systems.

The name 'BASIC' (3) (stand) ..... for Beginner's All-purpose Symbolic Instruction Code. The original BASIC language (4) (create) ..... in 1965 and adopted by many programmers and PC manufacturers because it was user-friendly and easy to learn.

The adjective 'Visual' refers to the technique used to create a graphical user interface. Instead of (5) (write) ..... a lot of instructions to describe interface elements, you just (6) (add) ..... pre-defined objects such as buttons and dialog boxes, which can (7) (choose) ..... from a toolbox.

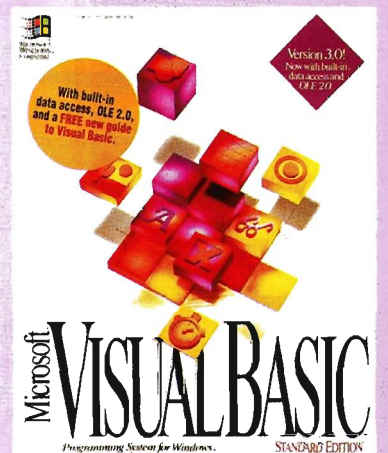

It (8) (take) ..... only a few minutes to create a Visual BASIC program. Using the mouse, you simply (9) (drag) ..... and drop controls (e.g. option buttons, text boxes, icons, menu bars, etc.) into the required position, and then define their colour, size and behaviour. Thanks to its object-oriented philosophy and interactive nature, Visual BASIC (10) (enable) ..... the programmer to quickly create all sorts of applications from small system utilities to database programs and Internet server applications.

## 6 Listening

**A**  Listen to Vicky Cameron, the IT lecturer from Unit 7, talking to her students about C language. Complete the table with the relevant information.

<i>Developed by</i>	<i>Date</i>	<i>Characteristics</i>	<i>Uses</i>	<i>Extensions</i>
Dennis Ritchie at .....	.....	Created to replace ..... ..... The language is small, .....	Originally designed for ..... ..... ..... Today it is used to .....	C++ and ..... Object-oriented languages.

**B** Now write a paragraph describing C. You can start like this:

*C is a high-level programming language developed ...*

```
#include <stdio.h>
main()
{
    printf("good morning\n");
}
```

*This C program tells the computer to print the greeting 'good morning'*



# 1 Warm-up

**A** The term 'Java' refers to three things:

- a an island in Indonesia
- b a cup of coffee, in American slang
- c a language for Internet applications.

But what exactly is Java?

Look at the illustrations and try to answer these questions.

- 1 What is Java, in the world of computers?
- 2 Have you seen the effects of Java programs on web pages?

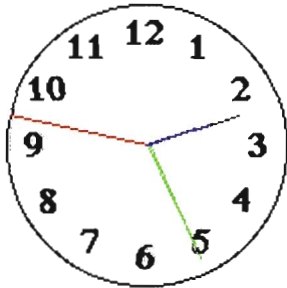

**Clock:** featuring an analogue display which you can modify by changing the colour of the background.



**Land Rover applet:** allows you to change the look of the vehicle.

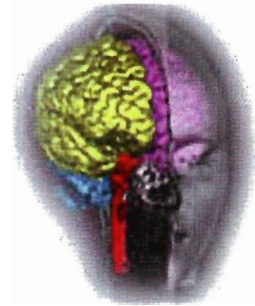

**The JavaMan applet,** used in medical research.



Advertising banner

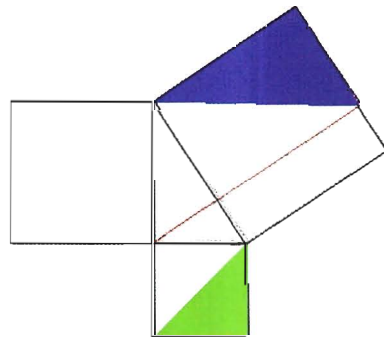

A geometrical proof of Pythagoras' Theorem



You can find free applets available for use on your websites at <http://java.sun.com/>.

**B** Can you guess the meaning of these words? Use the Glossary if necessary.

- |                 |           |
|-----------------|-----------|
| applet          | plug-in   |
| object-oriented | real-time |
| compiler        | download  |

## 2 Reading

These statements about Java are all false. Read the text and correct them.

- 1 Java was invented by Microsoft.
- 2 Small applications written in Java are called 'animations'.
- 3 With the interpreter, a program is first converted into Java bytecodes.
- 4 Java is not compatible with most computing platforms.
- 5 The Java language is single-threaded, one part executing at a time.
- 6 Java doesn't let you watch animated characters on your webpages.
- 7 ActiveX and Shockwave are not real competitors for Java.



*Java Steaming Coffee Cup  
(the Java Technology logo)*

### What is Java?

Java is a programming language developed by Sun Microsystems which is specially designed to run on the web. When you see a web page that uses Java, a small program called 'applet' is executed automatically. Java applets let you watch animated characters and moving text, play music and interact with information on the screen.

#### Characteristics of the Java language

Java is an object-oriented language similar to C++, but it is more dynamic and simplified to eliminate possible programming errors.

A Java program is both compiled and interpreted. First the source code (file with a .java extension) is compiled and converted into a format called bytecode (file with a .class extension), which can then be executed by a Java interpreter. Compiled Java code can run on most computers because there are Java interpreters, known as Java Virtual Machines, for most operating systems, including MacOS, Windows, or UNIX.

Java is multi-threaded. A Java program can have multiple threads (parts), i.e. many different things processing independently and continuously.

#### Why is Java cool?

People are excited about Java because it lets you create moving images and animated drawings. You can also create graphical objects (e.g. bar charts, graphs, diagrams) and new 'controls' (e.g. buttons, check boxes, pushbuttons with special properties). A web page that uses Java can have inline sounds that play in real-time, music that plays in the background, cartoon style animations, real-time video and interactive games.

#### Alternatives to Java

One alternative technology is ActiveX, the Microsoft product for including multimedia effects on web pages. Another competitor is Macromedia's Shockwave, a plug-in that lets you animate pictures, add sound and even make interactive pages so that people can play games on websites.

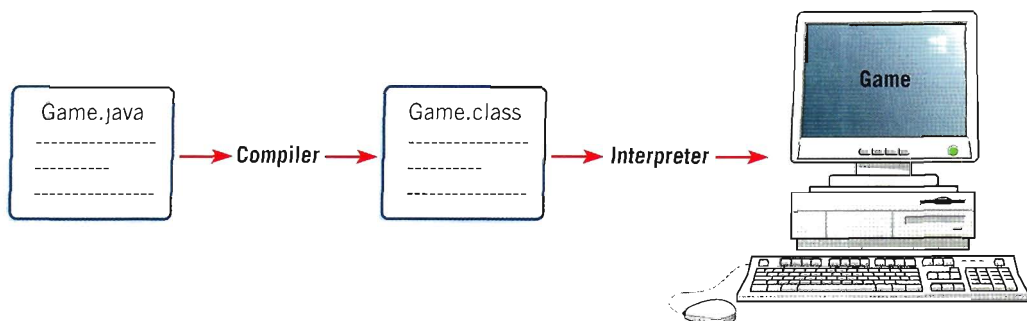

### 3 Vocabulary

**A Match each word on the left with its partner to make a common technical term.**

- |               |              |
|---------------|--------------|
| 1 programming | a browser    |
| 2 web         | b error      |
| 3 Java        | c code       |
| 4 multimedia  | d protection |
| 5 source      | e format     |
| 6 virus       | f effects    |
| 7 compression | g applet     |

**B Which verbs on the left are frequently found with nouns on the right?**

- |               |                    |
|---------------|--------------------|
| 1 to download | a the Web          |
| 2 to play     | b a source program |
| 3 to run      | c files            |
| 4 to browse   | d an application   |
| 5 to compile  | e data             |
| 6 to process  | f music            |

### 4 Language work: The past simple

**A**  **Look at the HELP box and then listen to these verbs. Put them in the right column.**

developed	asked	described
decided	produced	supplied
watched	generated	published
persuaded	programmed	combined
scaled	interpreted	arranged

#### HELP box The past simple

- Regular verbs add *-ed* to form the past simple (the affirmative form).

- Pronunciation of the *'-ed'*

The *-ed* is pronounced as:

- /t/ after voiceless sounds: /p/, /k/, /θ/, /s/, /f/, /ʃ/, /tʃ/: *stopped, talked*
- /d/ after voiced sounds: /b/, /g/, /ð/, /z/, /v/, /dʒ/, /l/, /r/, nasal consonants /m/, /n/, /ŋ/ and vowels: *visualized, plugged, specified*
- /ɪd/ after /t/ or /d/: *wanted, needed*

/t/	/d/	/ɪd/
.....	.....	.....
.....	.....	.....
.....	.....	.....
.....	.....	.....
.....	.....	.....

- B**  Read the passage below and complete it with the correct form of the verbs in the box. Then listen and check your answers.

call	decide	develop	be	begin
can	rename	have	support	base

The idea for Java started in 1990 when a team of software engineers at Sun Microsystems (1) ..... to create a language for a handheld device that could control and interact with various kinds of electronic appliances ranging from Nintendo game boys to VCRs and TV set-top boxes. They (2) ..... an object-oriented programming language that Gosling (3) ..... 'Oak', after the tree outside his window. The device (4) ..... an animated character named 'Duke', which would go on to become Java's mascot.

With the advent of the Web in 1993, the company made a web browser (5) ..... on the Oak language. Later on, this language was adapted to

the Internet and (6) ..... 'Java'. The 1.0 version of Java was officially introduced by Sun in May 1995.

At that time, web pages (7) ..... only display text, pictures and hyperlinks. With the arrival of Java, web designers (8) ..... able to include animation and interactive programs on web pages. The first major application created with Java was the HotJava browser. The Java language (9) ..... to attract serious attention from the Internet community and was soon (10) ..... by Netscape Navigator and Microsoft Internet Explorer. Today Java is a hot technology that runs on any computer.

## 5 Your experience with computers

- A** Complete the chart below with notes about the different stages in your 'computer history'. For example: *1985: First used computer at school.* Add more boxes to the chart if you want to.

Possible stages:

- first computer game
- first computer lesson at school/college
- first programming language learnt
- first software used
- first computer course/qualification
- first job involving computers
- first steps on the Internet

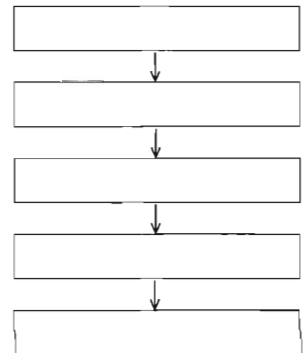

- B** Ask a partner about their computer history. For example:

'When did you first ...?'

'How long ago did you ...?'

'How old were you when you ...?'

- C** Tell the rest of the class about your partner. Do most people in your group have similar computer histories?

## 1 Reading

- A** Look carefully at the job advertisements and discuss with another student what personal qualities and professional abilities you would need for each job. Tick (✓) the most important qualities in the list. Then add some more of your own.

logical reasoning	<input type="checkbox"/>	ability to lead a team	<input type="checkbox"/>
imagination	<input type="checkbox"/>	patience and tenacity	<input type="checkbox"/>
physical fitness	<input type="checkbox"/>	ability to draw well	<input type="checkbox"/>
efficiency	<input type="checkbox"/>	being good with figures	<input type="checkbox"/>
self-discipline	<input type="checkbox"/>	willingness to take on responsibility	<input type="checkbox"/>

**SENIOR PROGRAMMER**

required by **DIGITUM**, a leading supplier of business systems to the insurance industry.

You will be able to work on the full range of development activities — analysis, design, coding, testing and implementation. At least two years' experience of COBOL is necessary.

As we are active in Europe, fluency in French, Italian or another European language is desirable.

Don't miss this opportunity to learn new skills and develop your career.

Send your curriculum vitae to  
**CHRIS SCOTT, PERSONNEL MANAGER,**  
DIGITUM, 75 PARKHILL STREET, LONDON SW2 3DE

You can visit our Web site at:  
<http://www.digitum.com>

**DTP Operator**

required for a leading financial magazine. We are looking for a bright, competent QuarkXPress operator with at least three years' experience in design and layout. Skills in Photoshop, Freehand or Illustrator an advantage. Ability to work in a team and to tight deadlines is vital.

Please apply in writing, with CV and samples of your work, to  
**Tom Parker, Production Manager,**  
Financial Monthly, Stockton  
Street, London EC1 4WW

- B** Would you like to apply for one of these jobs? Why?

- C** Study the personal profile of Charles Graham. Which is the **most suitable job** for him?

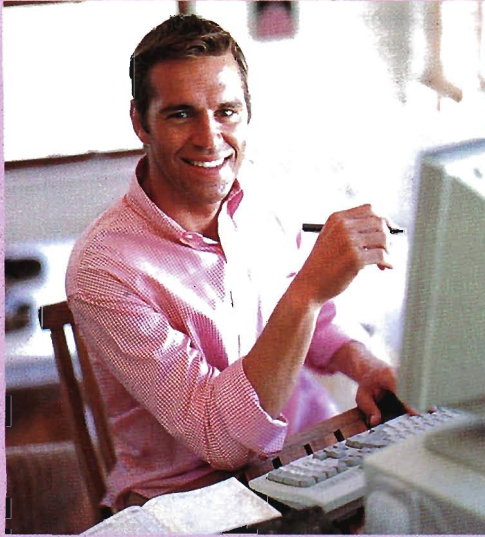

**Charles Graham**

- 28 years old. Married.
- Education: 3 A-levels.
- In-depth knowledge of Apple Macintosh equipment.
- Course in graphic design and page-layout applications from Highland Art School.
- Proficient in Adobe PageMaker.
- Diploma in word processing. Wide experience in MS Word and WordPerfect.
- Present job: Computer operator for PromoPrint, a company specializing in publishing catalogues and promotional material.

## 2 Language work: Past activities

- A** Look at the **HELP** box and then complete the sentences below using *for*, *since* or *ago*.

**HELP box**  
*for, since, ago*

*for:* We've used Microsoft Internet Explorer **for** two years.

*since:* I've been a programmer **since** 1993.

*ago:* I left university seven years **ago**.

- 1 I've been looking for a job ..... April.
- 2 They've used a fax machine ..... the past two years.
- 3 Kate Jackson studied computer sciences ..... three years.
- 4 I got married six years .....
- 5 She's been working for this firm ..... 1990.

**What is the difference in meaning between these two sentences?**

- a I've worked for a year as a senior programmer.
- b I worked for a year as a senior programmer.

**B Sarah Brown is one of the applicants for the job of Senior Programmer advertised in Task 1. Read her letter of application and put the verbs in brackets into the correct tense.**

19 Sandford Street  
London NW7 4HH

2 March 1999

Mr Scott  
Personnel Manager  
Digitum  
75 Parkhill Street  
London SW2 3DE

Dear Mr Scott,

I am writing to (1) (apply) ..... for the position of Senior Programmer which (2) (advertise) ..... on 28 February in *The Times*.

I (3) (work) ..... as a computer programmer for the last three years. After graduation I (4) (work) ..... for a year with NCR and (5) (be) ..... now ..... with Intelligent Software for two years. I design systems in COBOL for use in large retail chains. These have been very successful and we (6) (win) ..... several new contracts in the UK and Europe on the strength of my team's success.

Last year I (7) (spend) ..... three months in Spain testing our programs and also (8) (make) ..... several short visits to Italy so I have a basic knowledge of Spanish and Italian. I now feel ready for more responsibility and more challenging work and would welcome the opportunity to learn about a new industry.

I enclose my curriculum vitae and look forward to hearing from you.

Yours sincerely,

Sarah Brown

Sarah Brown

### 3 Listening

**A  Listen to part of Chris Scott's interview with Sarah Brown and complete his notes.**

Name: Sarah Brown  
Address: 19 Sandford Street, London NW7 4HH  
Home phone no: 0181 569 1260  
Job applied for: Senior Programmer  
Qualifications:  
- University: .....  
- Foreign languages: Basic knowledge of Italian and Spanish

Work experience:  
- At NCR .....  
- What was software used for? .....  
- What computers were used? .....  
- Knowledge of databases? .....  
- Present job: Works for Intelligent Software; writes programs in COBOL  
Reasons for applying: .....

**B  Listen again and check your answers. Then compare your answers with a partner.**

## 4 Writing

María Quintana, from Spain, is interested in the job of computer operator as advertised below. Use her notes to write a letter applying for the job.

You can start like this: *I'm writing to apply for ...*



international  
mercury  
computers

### requires Computer Operators

We have vacancies for experienced operators to work on their own initiative in a busy company. You will be responsible for the day-to-day running of our data-processing equipment.

You must be highly communicative and have good problem-solving skills. We can offer an excellent salary, training and good promotional prospects to the right candidate.

Send your CV and a covering letter to  
James Taylor, International Mercury Computers,  
37 Charles Place, London SW10 6XX  
FAX 0171-323-0571

### Notes for the Curriculum Vitae

- Cambridge Certificate of Proficiency in English
- Computer Sciences degree from Zaragoza University, Spain
- Knowledge of both Macintosh and Windows environments
- Two years' experience working on 'Linea Directa', a local magazine for computer users
- Present job: Computer operator for Graphic Color SL. This involves data control and editing, data preparation, and computer operating
- Reasons for applying: Wants to develop operating skills and move into management



Enter the Infotech website at [www.cambridge.org/elt/infotech](http://www.cambridge.org/elt/infotech).

Then go to the Web links section and do the activity The job of your dreams?

# Computers tomorrow

Unit		page
27	<i>Electronic communications</i>	123
28	<i>Internet issues</i>	128
29	<i>LANS and WANS</i>	133
30	<i>New technologies</i>	138

## Learning objectives

*In this section you will learn how to:*

- talk about different kinds of data communication systems: teletext, fax, local bulletin boards and the Internet
- describe the components and functions of a computer network, in oral and written form
- understand and discuss basic ideas about security and privacy on the Internet
- talk and write about new technologies
- understand how a handheld computer works
- make predictions about the impact of computers on our lifestyle.

# Unit 27 *Electronic communications*

## 1 Before you read

Try to answer these questions.

- 1 How can a PC be connected to another computer?
- 2 What data communication systems can you think of? Make a list.

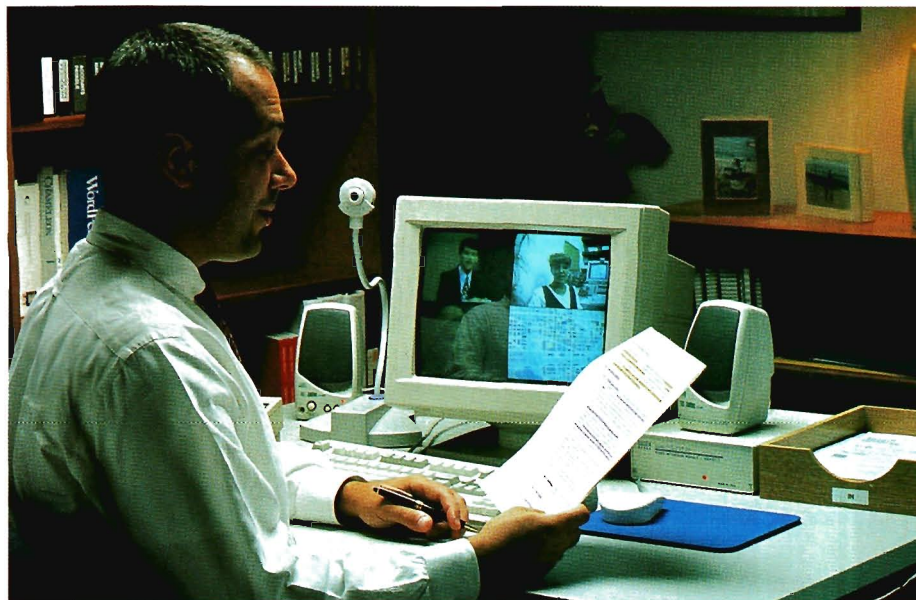

## 2 Reading

**A** Match the data communication services on the left with the requirements on the right. Then read the passage and check your answers.

- |                                     |                                                                                                                             |
|-------------------------------------|-----------------------------------------------------------------------------------------------------------------------------|
| 1 fax                               | a To send a personal message to a friend who is at a different workstation.                                                 |
| 2 electronic mail (e-mail)          | b To send a copy of a paper document – for instance, a scientific article – from Trento University to Cambridge University. |
| 3 teletext                          | c To access massive databases containing all kinds of information, or to be connected with an airline reservations service. |
| 4 local bulletin board system (BBS) | d To receive shareware and public domain programs from a user group.                                                        |
| 5 commercial online service         | e To find out weather forecasts and sports information from the television.                                                 |

## Channels of communication

### What are 'telecommunications'?

This term refers to the transmission of information over long distances using the telephone system, radio, TV, satellite or computer links. Examples are two people speaking on the phone, a sales department sending a fax to a client or someone reading the teletext pages on TV. But in the modern world, telecommunications mainly means transferring information from one PC to another via modem and phone lines (or fibre-optic cables).

### What can you do with a modem?

A modem is your computer's link to the external world. With a modem you can exchange e-mail and files with friends and colleagues; you can access the Web and search for information about the stock market, current affairs, entertainment, etc.; you can participate in newsgroups and live conversations; you can make bank transactions and buy things from the comfort of your home. You can also access your office from your computer at home or your laptop in a hotel room.

### Modems

*Your PC is a digital device (it works with 1s and 0s). However, the telephone is an analogue device, designed to transmit the sounds of the human voice. That's why we need a modem — a bridge between digital and analogue signals. The word 'modem' is an acronym for MOdulator/DEModulator. When a modem modulates, it sends rapid on/off pulses. The computer on the other end translates (demodulates) those signals into intelligible text or graphics. Modem transmission speeds are measured in kilobits per second. The conventional modem transmits data at 56 kbps; a cable modem offers speeds of up to 2 Mbps; and an ADSL modem supports data rates of 1.5 to 9 Mbps.*

Today a lot of companies find it more efficient to have some employees doing their work at home. Using a modem, they transfer their work into the office where it is printed and distributed. The list of applications is endless.

### What do you need to telecommunicate?

You just need a PC (or a terminal), a modem connected to the computer and the telephone line, and communication software. Once you have installed and configured your modem, you can communicate with people through bulletin boards and online services.

### Local bulletin boards

Bulletin board systems (BBS) are frequently free because they are run by enthusiasts and sponsored by user groups or small businesses. The person who administers the BBS is called *sysop* (system operator). You can use a BBS to download artwork, games and programs, or you can participate in ongoing discussions. You can also upload (send) programs, but make sure they are shareware or public domain programs.

### Online service providers

To gain access to the Net you must first open an account with a service provider.

- **Internet service providers** give you a software package, username, password and access phone number. You can then log on to the Internet and browse the web, download files from FTP sites, and send and receive e-mail. Most ISPs charge a flat monthly or annual fee that gives you unlimited access.

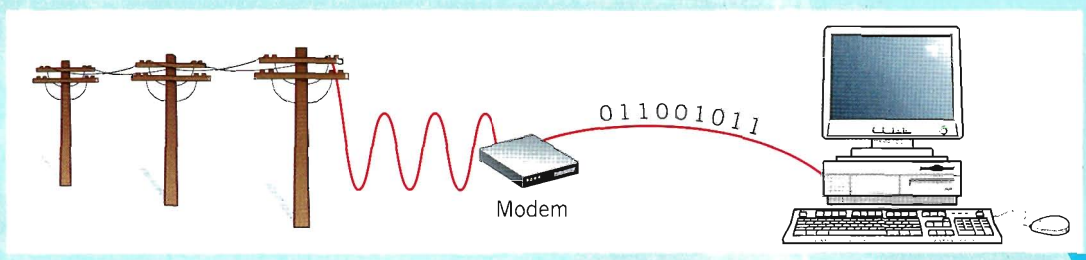

- **Commercial online services** e.g. America Online, CompuServe and the Microsoft Network. They differ from dedicated ISPs in two ways: (1) they use a smooth, easy-to-use

interface, and (2) they have extra services for members only (but they charge higher prices). For example, they offer airline reservations, professional forums, etc.

A *fax machine* sends and receives copies of original documents via a phone line



*Teletext* on ITV and Channel Four is an information service in Britain which broadcasts a database alongside the TV signal. It provides constantly updated and real time information

**B Complete the sentences by using a term from the list. Then write the words in the crossword.**

modem network online download newsgroups services account telephone

- 1 When you are connected to the Internet you are described as being .....
- 2 To communicate via the Internet you need a PC, a modem and a ..... line.
- 3 To have access to the Internet you must first open an ..... with an Internet service provider.
- 4 You need a ..... to convert computer data into a form that can be transmitted over the phone lines.
- 5 The public discussion areas on the Internet are called .....
- 6 You can use a BBS to ..... clip-art, games and shareware to your PC.
- 7 CompuServe and America Online offer exclusive ..... to their customers.
- 8 The Internet is a global ..... of computer networks.

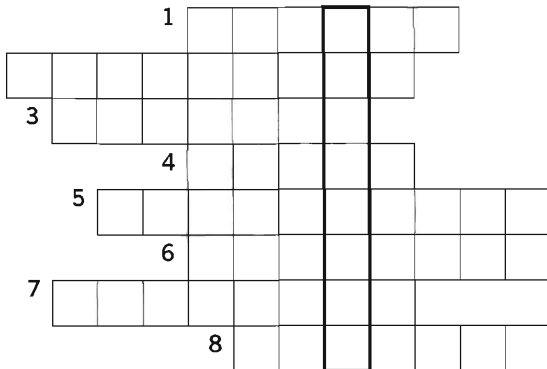

**C Match and link the pairs of expressions that have the same meaning.**

file of structured data    BBS    facsimile machine    FTP    sysop  
 kilobits per second    system operator    modem    Internet relay chat  
 phone network    fax    database    bulletin board system    IRC  
 modulator/demodulator    file transfer protocol    kbps    telephone wires

## 3 Word building

### A In pairs, look at the words below and decide:

- what part of speech each word is
- where the stress falls on each item.

If you are not sure, look them up in a dictionary.

*tele-* means 'at/over a distance'

- |              |               |                    |                |
|--------------|---------------|--------------------|----------------|
| 1 telegram   | 5 teletype    | 9 telegraphic      | 13 telescope   |
| 2 telephoto  | 6 teletext    | 10 telegraphically | 14 telescopic  |
| 3 televise   | 7 telegraph   | 11 telepathy       | 15 telephonist |
| 4 television | 8 telegrapher | 12 telepathic      |                |

### B Now write down some words formed by adding these prefixes.

- 1 *auto-* (means 'self')
- 2 *trans-* (means 'across from one place to another')
- 3 *inter-* (means 'between', 'among')

## 4 Listening

### A Look at the photo on page 127 and try to answer these questions.

- 1 What is a cybercafé?
- 2 What services would you expect when entering a cybercafé?

### B Listen to this interview with Daniel Sturdy, the manager of an Internet café in London. Then say whether these sentences are true (T) or false (F).

- 1 A cybercafé is a café where you can have access to the Internet and related services.
- 2 You can talk to people over the Internet as if you were speaking on the phone.
- 3 They don't help people who have problems while using the Internet.
- 4 A private e-mail account costs £10 a month.
- 5 At the moment they have got many international users.
- 6 You have to pay long-distance rates on the Internet.
- 7 In the café area you can sit, drink coffee and chat to people.
- 8 Most of the computers are in an upstairs area.



A London cybercafé

### C Mini-project: Plan your own cybercafé!

Imagine you want to open an Internet café in town. In pairs, look at the HELP box and make a project about a café.

#### HELP box

Consider the following:

- the **money** you need to set up and run your cybercafé
- the kind of **visitors** you would like to have
- the **location**
- the **services** you want to offer (food, drinks, coffees, etc.)
- the type of **furniture**
- the things that can help you create a **relaxing atmosphere** (music, decoration, lighting, private areas, etc.)
- whether you want to have second-hand **books**, classic literature or **magazines** about computers and the Internet.

Make decisions about:

- the type of Internet connection: via a cable modem, an ADSL modem, etc.
- hardware equipment (Macs and PCs, printer, fax, etc.)
- software (web browser, e-mail, online chatting, games on CD-ROMs, etc.)
- how much you will charge customers for your services
- classes for users.

Now choose a name and a slogan for your cybercafé.



Enter the Infotech website at [www.cambridge.org/elt/infotech](http://www.cambridge.org/elt/infotech)

Then go to the Study online section and do the activity What is Internet 2?

## 1 Warm-up

### A Try to answer these questions.

- 1 Is it technically possible for computer criminals to infiltrate into the Internet and steal sensitive information?
- 2 What is a hacker?
- 3 Can viruses enter your PC from the Internet?

### B Match these texts with the correct pictures.

- 1 Web browsers warn you if the connection is not secure; they display a message when you try to send personal information to a server.
- 2 Private networks use a software and hardware mechanism, called a 'firewall', to block unauthorized traffic from the Internet.
- 3 You have to type your user name and password to access a locked computer system or network.
- 4 An open padlock in Netscape Communicator indicates the page is not secure; a closed padlock indicates the page is encrypted (secure).

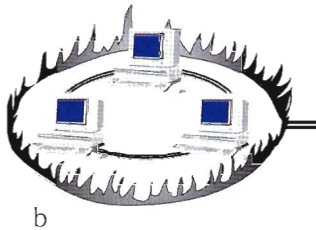

## 2 Reading

### A Read the text on page 129 and find answers to these questions.

- 1 Why is security so important on the Internet?
- 2 What security features are offered by Netscape Communicator and Internet Explorer?
- 3 What security standard is used by most banks to make online transactions secure?
- 4 How can we protect and keep our e-mail private?
- 5 What methods are used by companies to make internal networks secure?
- 6 Which ways can a virus enter a computer system?

## Security and privacy on the Internet

There are a lot of benefits from an open system like the Internet, but we are also exposed to hackers who break into computer systems just for fun, as well as to steal information or propagate viruses. So how do you go about making online transactions secure?

### Security on the Web

The question of security is crucial when sending confidential information such as credit card numbers. For example, consider the process of buying a book on the Web. You have to type your credit card number into an order form which passes from computer to computer on its way to the online bookstore. If one of the intermediary computers is infiltrated by hackers, your data can be copied. It is difficult to say how often this happens, but it's technically possible.

To avoid risks, you should set all security alerts to high on your Web browser. Netscape Communicator and Internet Explorer display a lock when the Web page is secure and allow you to disable or delete 'cookies'.

If you use online bank services, make sure your bank uses digital certificates. A popular security standard is SET (secure electronic transactions).

### E-mail privacy

Similarly, as your e-mail message travels across the net, it is copied temporarily on many computers in between. This means it can be

read by unscrupulous people who illegally enter computer systems.

The only way to protect a message is to put it in a sort of 'envelope', that is, to encode it with some form of encryption. A system designed to send e-mail privately is *Pretty Good Privacy*, a freeware program written by Phil Zimmerman.

### Network security

Private networks connected to the Internet can be attacked by intruders who attempt to take valuable information such as Social Security numbers, bank accounts or research and business reports.

To protect crucial data, companies hire security consultants who analyse the risks and provide security solutions. The most common methods of protection are passwords for access control, encryption and decryption systems, and firewalls.

### Virus protection

Viruses can enter a PC through files from disks, the Internet or bulletin board systems. If you want to protect your system, don't open e-mail attachments from strangers and take care when downloading files from the Web. (Plain text e-mail alone can't pass a virus.)

Remember also to update your anti-virus software as often as possible, since new viruses are being created all the time.

## HELP box

- **hacker:** a person who obtains unauthorized access to computer data
- **cookies:** small files used by Web servers to know if you have visited their site before
- **certificates:** files that identify users and Web servers on the net, like digital identification cards
- **encryption:** the process of encoding data so that unauthorized users can't read it
- **decryption:** the process of decoding encrypted data transmitted to you

**B Complete these sentences by using a term from the text. Then write the words in the puzzle.**

- 1 Users have to enter a p..... to gain access to a network.
- 2 You can download a lot of f..... or public domain programs from the net.
- 3 Hundreds of h..... break into computer systems every year.
- 4 A computer v..... can infect your files and corrupt your hard disk.
- 5 The process of encoding data so that unauthorized users can't read the data is known as e.....
- 6 A f..... is a device which allows limited access to an internal network from the Internet.
- 7 You can include an a..... as part of your e-mail message.
- 8 This company uses d..... techniques to decode (or decipher) secret data.

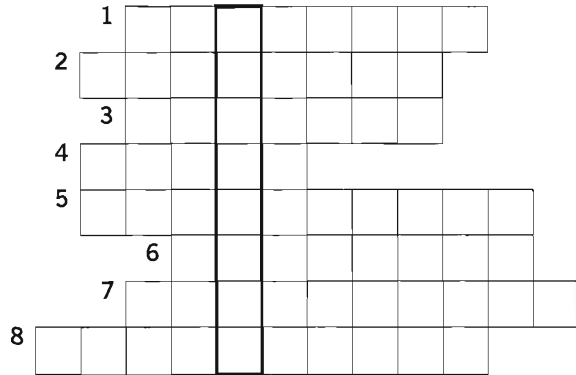

### 3 Listening

Listen to Diana Wilson, a member of the Internet Safety Foundation. She is talking about cyberspace's dangers and benefits for children. Complete the notes in this table.

**Benefits**

- The Internet brings benefits for (1)..... and entertainment.

**Risks**

- manipulation of children
- invasions of (2).....
- child (3) .....
- violence and neo-Nazi (4) .....

**Solutions**

- There are websites (5) ..... for children.
- Internet (6) ..... programs let parents block objectionable Web sites.
- Websites should (7) ..... their content with a label, from child-friendly to over 18-only.

But this may limit free expression.

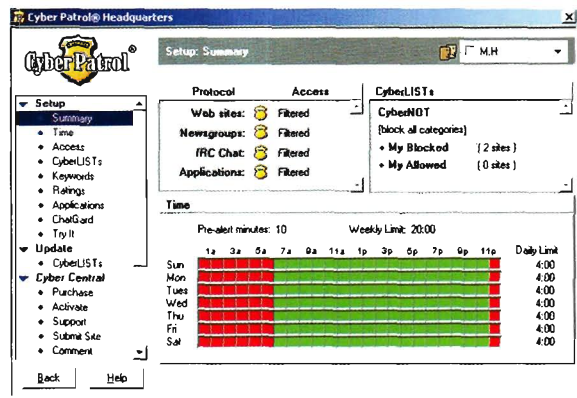

*CyberPatrol, from SurfControl, Inc [the popular Internet filtering software] <http://www.surfcontrol.com>*

## 4 Hackers!

Read the text in order to answer these questions.

- 1 Which hacking case inspired the film *War Games*?
- 2 Why was Nicholas Whitely arrested in 1988?
- 3 How old was the hacker that cracked the US defence computer in October 1989?
- 4 Who was known as 'Dark Dante' on the networks? What was he accused of?
- 5 Which computer club showed on TV a way to attack bank accounts?
- 6 What type of virus infected thousands of PCs in 2001?

- Sept '70 John Draper, also known as Captain Crunch, discovers that the penny whistle offered in boxes of Cap'n Crunch breakfast cereal perfectly generates the 2,600 cycles per second (Hz) signal that AT&T used to control its phone network at the time. He starts to make free calls.
- Aug '74 Kevin Mitnick, a legend among hackers, begins his career, hacking into banking networks and destroying data, altering credit reports of his enemies, and disconnecting the phone lines of celebrities. His most famous exploit – hacking into the North American Defense Command in Colorado Springs – inspired *War Games*, the 1983 movie.
- Jul '81 Ian Murphy, a 23-year-old known as Captain Zap on the networks, gains instant notoriety when he hacks into the White House and the Pentagon.
- Dec '87 IBM international network is paralysed by hacker's Christmas message.
- Jul '88 Union Bank of Switzerland 'almost' loses £32 million to hacker-criminals. Nicholas Whitely is arrested in connection with virus propagation.
- Oct '89 Fifteen-year-old hacker cracks US defence computer.
- Nov '90 Hong Kong introduces anti-hacking legislation.
- Aug '91 Israelis arrest 18-year-old for hacking foreign banking and credit card networks.
- Dec '92 Kevin Poulsen, known as 'Dark Dante' on the networks, is charged with stealing tasking orders relating to an Air Force military exercise. He is accused of theft of US national secrets and faces up to 10 years in jail.
- Feb '97 German Chaos Computer Club shows on TV the way to electronically obtain money from bank accounts using a special program on the Web.
- May '99 Computer criminals propagate a lot of viruses through the Internet.
- Feb '00 A massive 'denial of service' attack is launched against websites like Yahoo, Amazon and eBay.
- Aug '01 'Code Red' computer worm infects many PCs through the Internet.

## 5 Language work: The past simple (revision)

Look at the text in Task 4 again and put the verbs into the past.

### Example

*In September 1970, John Draper discovered that the penny whistle ... generated ... He started to make free calls.*

## 6 Discussion

### A Look at the list of cybercrimes and discuss these questions in small groups.

- 1 What type of crime is more dangerous?
- 2 What measures can be taken by governments against computer crime?
- 3 Personal information – address, salary, civil and criminal records – is usually kept or sold by governments and industries in electronic databases. Is personal privacy in danger?
- 4 Is it right to put restrictions on the contents of the Internet?

### B Write a summary of the discussion. Then present your view to the rest of the class.

#### Crimes on the Internet

- Virus propagation
- Software piracy
- Stealing data and passwords by using a sniffer program
- IP spoofing (making one computer look like another to gain unauthorized access)
- Fraudulent use of credit card numbers
- Child pornography
- Violence and racist propaganda

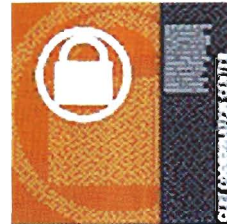

The CERT coordination center offers courses on Internet security.

[www.cert.org](http://www.cert.org)



Enter the Infotech website at [www.cambridge.org/elt/infotech](http://www.cambridge.org/elt/infotech)

Then go to the Web links section and do the activity Netiquette

# Unit 29 LANs and WANs

## 1 Warm-up

Try to answer these questions.

- 1 What is a computer network?
- 2 What are the benefits of connecting computers and peripherals in a network?

## 2 Listening

**A**  Listen to the description of this computer network. Label the different elements.

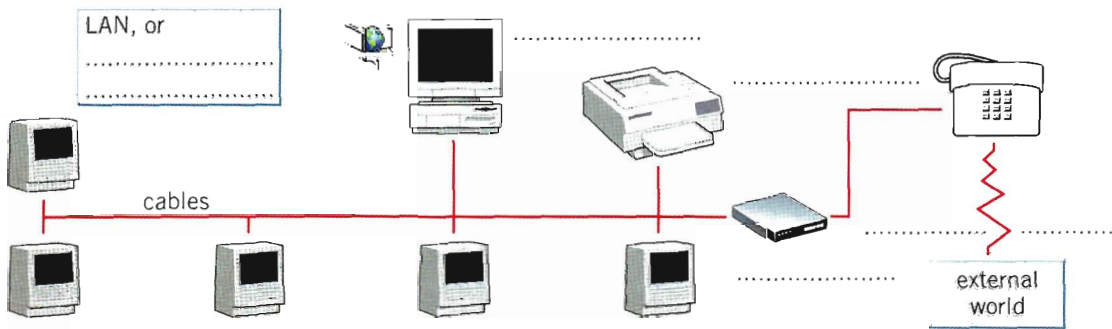

**B** With a partner, list some places where you may find a local area network.

## 3 Reading

Read the text on page 134, then match the technical terms on the left with the explanations on the right.

- |                        |                                                                                                                                                            |
|------------------------|------------------------------------------------------------------------------------------------------------------------------------------------------------|
| 1 LAN                  | a the hardware that emits and receives signals in a computer network                                                                                       |
| 2 network architecture | b a network contained in a relatively small area                                                                                                           |
| 3 nodes                | c the arrangement of nodes in a communication system (i.e. the distribution of elements in a network)                                                      |
| 4 protocol             | d a device that translates protocols between different types of networks (e.g. it can link networks of PCs and Macs to mainframes and minicomputers)       |
| 5 transceiver          | e a special unit of data which acts as a key on a Token Ring network; only the machine in possession of this piece of software can transmit on the network |
| 6 token                | f a set of rules that allows the exchange of information over a network                                                                                    |
| 7 gateway              | g computer devices interconnected in a network                                                                                                             |

## Network configurations

A **network** is a group of devices (PCs, printers, etc.) or 'nodes' connected by communications circuits so that users can share data, programs and hardware resources. A network has two main elements: the **physical structure** that links the equipment and the **software** that allows communication.

The physical distribution of nodes and their circuits is known as network 'topology' or 'architecture'. The software consists of the **protocols**, i.e. the rules which determine the formats by which information may be exchanged between different systems. We could say that cables and transceivers (the architecture) allow computers to 'hear' one another, while the software is the 'language' that they use to 'talk' to one another over the network.

*As regards* the cables, they consist essentially of the transceiver – the hardware that sends and receives network signals. At present the most widely used transceivers are Token Ring, Ethernet and LocalTalk. Token Ring is the most common method of connecting PCs and IBM mainframes. Most Token Ring adapters transmit data at a speed of 16 megabits per second. With Ethernet, data is transmitted at 100 Mbits/sec. The newest version, Gigabit Ethernet, supports data rates of 1 Gb per second. Ethernet provides a very robust, trouble-free architecture

with good levels of performance. *In this regard*, Ethernet is the best solution for fast and intensive activity.

LocalTalk transceivers are the cheapest of all because they are directly included in each Macintosh. However, they're a bit slow, which is why most Macs come with built-in Ethernet.

*As for* protocols, these are rules which describe things like transmission speed and physical interfaces. The Token Ring protocol avoids the possibility of collisions. To transmit data, a workstation needs a **token**, and as there is only one token per network, holding one guarantees sole use of the network. With Ethernet there are other options, of which TCP/IP (Transmission Control Protocol/Internet Protocol) is perhaps the most useful since it allows different operating systems to communicate with each other. *With regard to* LocalTalk networks, they use AppleTalk protocols. The Macintosh operating system includes the AppleTalk manager and a set of drivers that let programs on different Macs exchange information.

LANs can be interconnected by gateways. These devices help manage communications and control traffic on large networks. They change the data to make it compatible with the protocols of different networks.

## 4 Language work: Prepositional phrases of 'reference'

In the sentence *As for protocols, these are rules ...*, the expression *as for* marks the theme of the sentence.

Look at the words in the box below and combine them to make nine similar phrases of reference meaning 'concerning'. You can use words more than once. Look back at the text to find some of them.

with	to	in	for	as	on	the	regard
this	regards	matter	reference	of	respect		

## 5 Writing

- A** The diagram below illustrates the computer connections in three areas of a large company. Read the description of the office area network. Then write similar descriptions of the other two areas.

In the **office area**, the computers are connected in a Token Ring network. Various PCs have access to a file server, an IBM mainframe, an e-mail server and a printer.

The file server probably contains application programs like databases, spreadsheets and accounting packages. The mainframe contains large amounts of information about the company, administration work, etc.

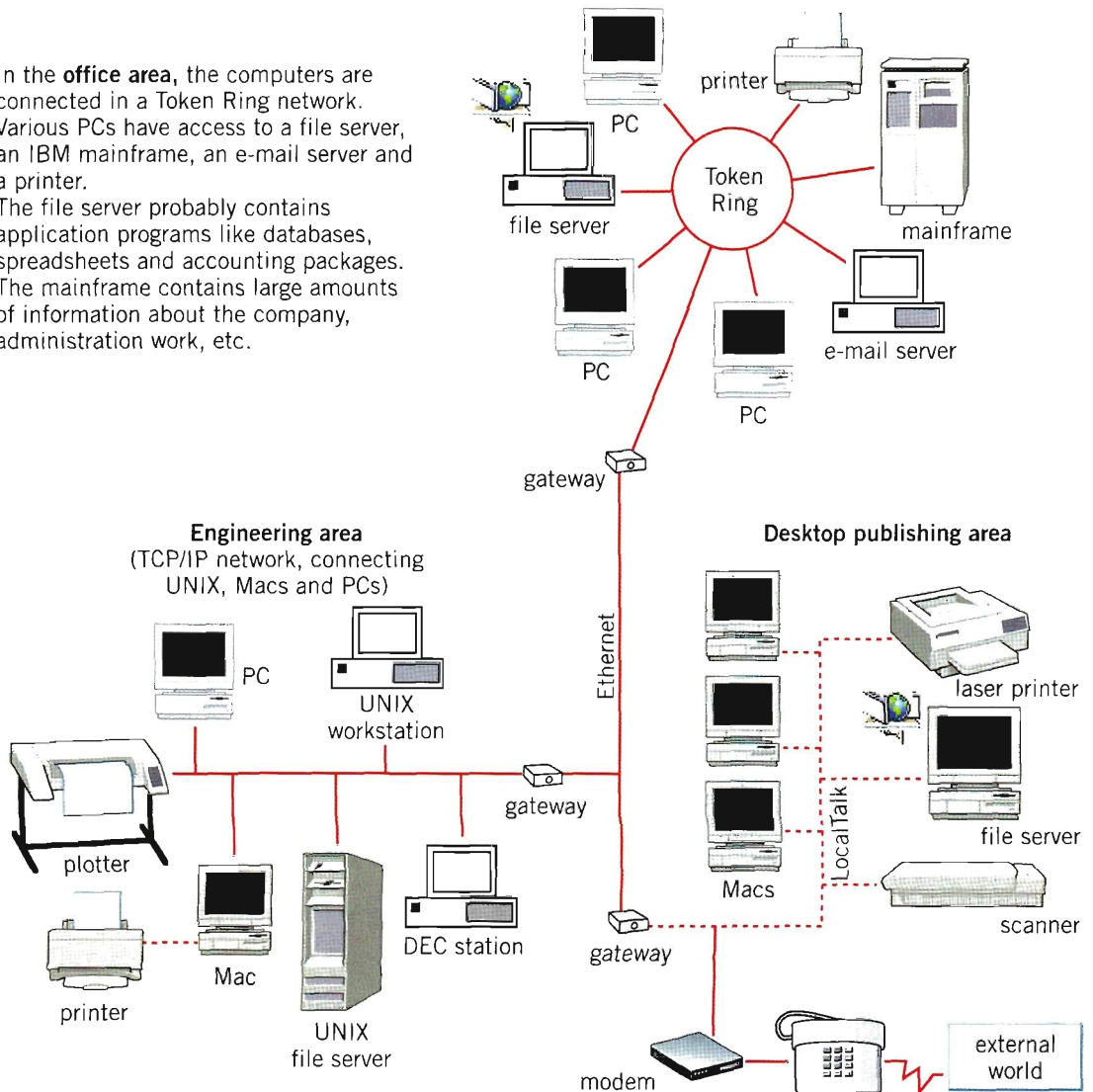

- B** If you use a network write a short description of it, with details of its architecture and protocol. Say what you and your colleagues use the network for.

## 6 WANs and worldwide communications

Try to answer these questions.

- 1 What is a WAN?
- 2 How can computers be linked up over a long distance?
- 3 What are the advantages of optical-fibre cables over telephone lines?
- 4 What is the function of communications satellites?

Now read the passage and find out if your answers were correct.

For long-distance or worldwide communications, computers and LANs are usually connected into a wide area network (WAN) to form a single, integrated network. The largest WAN in existence is the Internet.

Networks can be linked together by either **telephone lines** or **fibre-optic cables**. For example, ISDN (integrated services digital network) and ADSL (Asymmetric Digital Subscriber Line) are an international standard for transmitting digital text, sound, voice and video data over telephone lines. On the other hand, FDDI (fibre distributed data interface) is an optical-fibre network. It transmits data at great speed – 100 megabits per second. A variation called FDDT transmits data at 200 Mbps. FDDI networks are typically used as backbones for wide area networks.

Modern telecommunications use fibre-optic cables because data can be transmitted at a very high speed through the extremely wide bandwidths of glass fibres. The fibre system operates by transmitting light pulses at high frequencies along the glass fibre. This offers considerable advantages: (i) the cables require little physical space; (ii) they are safe because they don't carry electricity; (iii) they avoid electromagnetic interference.

Networks on different continents can also be connected via **satellite**. Computers are connected by a modem either to ordinary telephone wires or fibre-optic cables, which are linked to a dish aerial. This aerial has a large concave reflector for the reception and sending of signals. Then, when signals are received by the satellite, they are amplified and sent on to workstations in another part of the world.



*Libraries use a WAN to keep records of loans and to supply information to library users who have modems*

## 7 Speaking

In small groups, study and discuss the illustration below. Then prepare a description and give an oral report to the class.

- This diagram represents a wide area network or WAN. Two networks are linked via satellite. One network is in ..... and consists of ..... The other LAN is in ..... and contains .....
- In Los Angeles, the computers are connected to the telephone lines by ..... However, in Barcelona .....
- The satellite receives signals from ..... Then the signals are retransmitted to .....
- The purpose of this integrated network may be ..... It allows large companies and institutions to .....

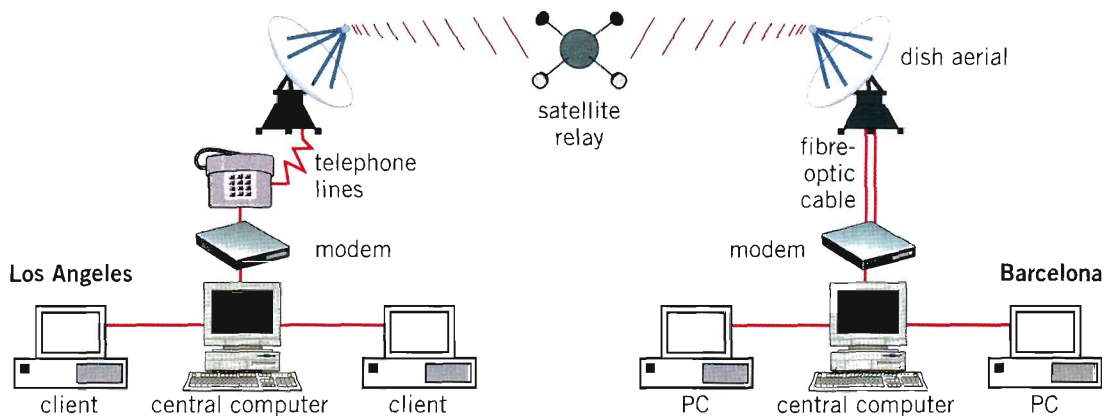

Enter the Infotech website at [www.cambridge.org/elt/infotech](http://www.cambridge.org/elt/infotech)

Then go to the Web links section and do the activity Wireless Connections

## 1 New products

A Look at these pictures and match them with texts 1 to 4.



b .....



a .....

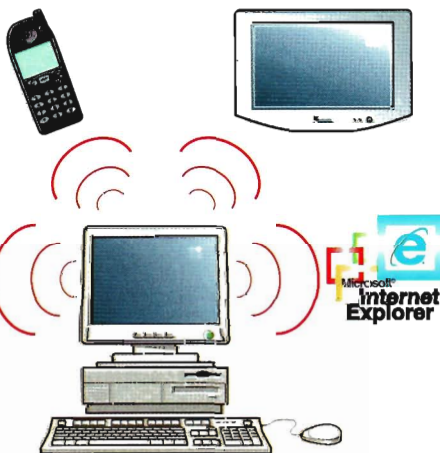

d .....



c .....

1 Not long ago, mobile phones could just transmit voice and SMS messages. Now they can display Internet information thanks to the Wireless Application Protocol or WAP.

Some hybrid models combine a phone with a PDA. They look like a regular phone with a dialpad and a small screen on its front. But if you flip up the front cover you find a larger screen that is touch-sensitive. Some include a virtual keyboard which pops up when you want to enter email text or a WAP address.

But the future is called 'third-generation' (3G) mobiles. They transmit a caller's picture and voice simultaneously. UMTS mobile phones deliver users information, e-commerce, games and videoconferencing via fixed, wireless and satellite networks.

- 2 Internet TV sets allow you to surf the Web and have e-mail while you are watching TV, or vice versa. Imagine watching a film on TV and simultaneously accessing a Web site where you get information on the actors in the film. This is ideal for people who are reluctant to use PCs but are interested in the Internet.

WebTV was the first company which brought Internet services to TV viewers through a set-top computer box. Another option is WorldGate's technology, which offers the Internet through cable TV.

The model built by OEM Metec integrates a complete Windows PC in a TV set. The next generation of Internet-enabled televisions will incorporate a smart-card for home shopping, banking and other interactive services.

- 3 Virtual reality lets people interact with artificial objects and environments through three-dimensional computer simulation. In a VR system, you are hooked to a computer through a controlling device, such as a glove, and head-mounted displays give you the feeling of being propelled into an artificial three-dimensional world. The computer brings to life events in a distant, virtual world using databases or real-time objects and sounds. Your senses are immersed in an illusionary, yet sensate, world.

VR can be applied to anything from video games, testing a motor vehicle, visiting a virtual exhibition, to checking out imaginary kitchen designs.

- 4 Bluetooth is a standard wireless technology designed to connect mobile phones, computers and other devices, replacing direct cable links. Since it uses high-frequency radio waves, the transfer of data and voice is very fast. All data are protected by advanced methods of encryption and authentication.

Bluetooth was initiated by Ericsson and the objective was to eliminate cables between mobile phones, PC cards, headsets, etc. Today it is supported by companies such as Nokia, IBM, Toshiba and Intel.

With Bluetooth, a handheld computer can be used to surf the Internet wherever you are, or to transfer files with other participants in meetings. Mobile phones will soon be used to control all sorts of gadgets in the house, from TV sets to refrigerators.

**B Write a suitable caption under each picture.**

**C Match the terms on the left with the explanations on the right.**

- |                       |                                                                                         |
|-----------------------|-----------------------------------------------------------------------------------------|
| 1 Internet-enabled TV | a location on the Internet where a company puts web pages                               |
| 2 Website             | b technology that allows users to see a computer simulated world in which they can move |
| 3 virtual reality     | c TV set used as an Internet device                                                     |
| 4 WAP                 | d device that can handle multiple data types including voice and video                  |
| 5 wireless            | e protocol that enables mobile phones to access Internet information                    |
| 6 3G mobile phone     | f without the use of cables                                                             |

## 2 Get ready for listening

Look at the computer in the photo and answer the questions about it.

- 1 What is different about this computer?
- 2 How do you enter information?
- 3 What kind of screen do you think it has: a cathode ray tube (CRT) or a liquid-crystal display (LCD)?
- 4 What sort of power supply do you think it uses?
- 5 If you had one, what would you do with it?

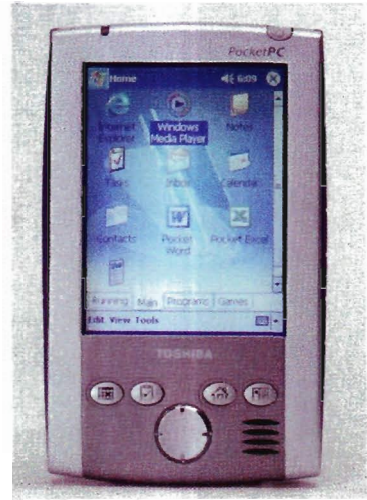

## 3 Listening

**A**  Listen to this interview with Tom Bryant, a writer with a computer magazine. Are the following sentences true (T) or false (F)?

- 1 Palmtops are a type of handheld computers.
- 2 Palmtops have a mouse and a keyboard as input devices.
- 3 Handheld computers run Windows XP.
- 4 Some pen computers come with operating systems that can recognize handwriting.
- 5 Handhelds are primarily designed to organize and communicate personal information.
- 6 You cannot transmit data from handheld computers to desktop PCs and peripherals.
- 7 Business people will make up a large section of the handheld market.

**B** Read this extract from the interview and fill in the missing words. The first letter of each missing word is given.

Interviewer: Some portable computers are referred to as laptops, and others as (1) p..... . Can you explain the difference?

Tom: Sure. Laptops are simply smaller versions of desktop PCs, but they can run similar applications. However, palmtops are (2) h..... computers and weigh less than 2 pounds; they're used as PC companions or as personal (3) d..... assistants.

Interviewer: And what are the basic features of palmtops?

Tom: Well, these handheld devices run on rechargeable alkaline batteries, and have small (4) k..... and high-contrast LCD (5) s..... . Sometimes they have buttons for launching applications and a stylus or (6) p..... which is used for interacting with a touch-sensitive screen.

Interviewer: Do they need specialized operating (7) s.....?

Tom: Yes. They usually run Palm OS from Palm Computing or Pocket PC OS, the system developed by Microsoft for mobile-computing devices.

Some pen-based systems can also (8) r..... handwritten characters and convert them into editable text.

Interviewer: Right. What sort of things can you do with handheld computers?

Tom: They're usually designed to store personal (9) i..... They have, for example, a calendar, an address book, a note pad, a calculator, and a voice recorder. They may also come with a built-in (10) m..... and Internet software which lets you send and receive e-mail from a payphone, a hotel or even a plane.

 **Now listen again and check your answers.**

### C How do you say these expressions in your language?

- |                           |                                |
|---------------------------|--------------------------------|
| 1 rechargeable batteries  | 5 a Personal Digital Assistant |
| 2 a flat LCD screen       | 6 an infra-red port            |
| 3 a pen-based interface   | 7 a portable supplement        |
| 4 handwriting recognition |                                |

## 4 Discussion

**Look at the picture below and read the text. Then discuss these questions in small groups, and prepare a short report for the class.**

- 1 What are the most important differences between handheld computers (e.g. palmtops, PDAs, etc.) and traditional computers?
- 2 What are the advantages and limitations of handheld computers?
- 3 Should students be allowed to use handheld computers in class?
- 4 Do you agree with this statement: 'Soon, handheld PCs will combine the functions of traditional PCs, cellular phones and pocket-size organizers'?



*Psion Series 5mX handheld computers have a keyboard and a touch-sensitive screen. Although very light weight, they have one month battery capacity, 16 MB of RAM, a windowing OS, a microphone for sound recording, and a full range of applications including an application which lets you send e-mail and browse the web.*

# 5 Language work: Making predictions

**A** Look at the HELP box and then expand these sentences using the future perfect tense.

- 1 In ten years' time/a lot of people/ connect their television to the telephone line
- 2 Portable PCs/replace/ desktop PCs/in a few years' time
- 3 With the help of computers/ doctors/find/cure/AIDS and cancer/by the year 2010
- 4 By this time next year/software manufacturers/make/hundreds of new programs
- 5 By 2020/post offices and bookshops/disappear
- 6 By this time next year/I/buy/ handheld computer

**HELP box**  
**Making predictions**

- Future with *will/shall*  
*A computer program will be the world chess champion.*
- Future continuous (*will be + present participle*)  
*In twenty years' time, some people will be living in space, inside a computerized colony.*
- Future perfect (*will have + past participle*)  
*By 2020, new technology will have revolutionized communications.*
- Special structures
  - Possibility (*may/might/could*)  
*Scientists may discover new electronic components.*
  - Probability (*likely to*)  
*Talking machines are likely to be built.*
  - Certainty (*certainly, definitely, certain to*)  
*Working hours will definitely become shorter with the help of computers. Prices are certain to go up.*

**B** Here are some predictions made by an intelligent supercomputer. In small groups, write your own predictions.

- Work/Jobs  
 e.g. *By the year 2030 human labour in industry will have been replaced by robots.*  
 Yours: .....
- Homes  
 e.g. *Families will have robots to do the housework.*  
 Yours: .....
- Education/Schools  
 e.g. *By the end of the next century, every student in every school in the world will have a PC.*  
 Yours: .....
- Money/Holidays  
 e.g. *Cash will disappear.*  
 Yours: .....

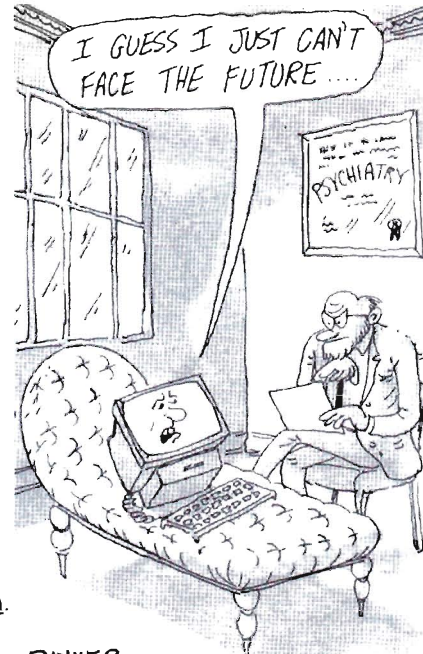

Enter the Infotech website at [www.cambridge.org/elt/infotech](http://www.cambridge.org/elt/infotech). Then go to the Web links section and do the activity The latest news.

# Notes for Student A

## Unit 6 Task 4 Speaking

Read these notes about two input devices. Then describe them to your partner. They have to guess what you are describing.

- scans text and pictures  
● sends digitized image to computer
- allows you to control computer vocally  
● spoken commands do what is normally done with keyboard/mouse

Now listen to your partner and guess which input device they are describing.

## Unit 19 Task 6 Speaking

Look at the graph below and describe it to your partner. Then answer your partner's questions.

### Useful constructions

*This is a two-/three-dimensional representation of ...*

*In 2002, they paid £ ... for ...*

*They spent £ ... on ...*

*As for ..., that cost them ...*

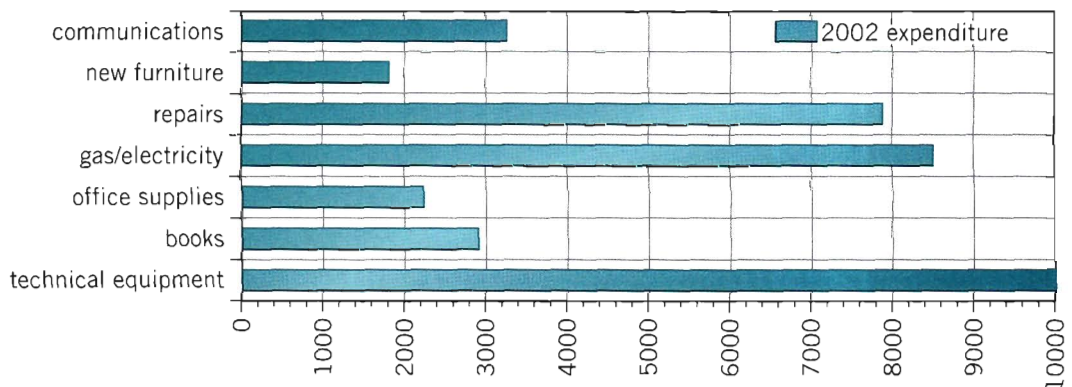

Graph 1 The 2002 expenditure of Lancashire College expressed in pounds

Now look at this graph and listen to your partner's description of it.  
Ask questions so that you can complete the graph.

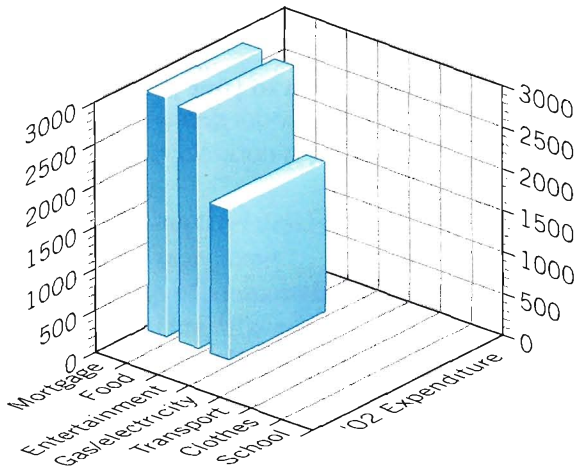

Graph 2 The 2002 expenditure of the Brown family expressed in pounds

## Unit 20 Task 5 Computers for newspapers

Read the information on the next page which Katherine Powell received from *El Independiente* and tell your partner about:

- the hardware used to produce the newspaper:
  - computers on the network
  - printers
  - data communication systems
- the software used to:
  - edit text
  - create illustrations
  - manipulate photographs
  - design the pages.

# El Independiente

- Hardware:
  - The newspaper is written and edited on PCs and Macintosh computers.
  - Several IBM servers (with 1 GB of RAM and 80 GB hard disk) are dedicated to managing communications on the network and storing common files.
  - Black-and-white proofs are printed by Epson ink-jet and laser printers. The final product is printed by imagesetters.
  - Different data communications systems — fax machines, e-mail, etc. — are used to communicate with newspaper correspondents. There is a Web edition published on the Internet.
- Software
  - The text is typed and edited with compatible word processors.
  - The illustrations (diagrams, charts, etc.) are created with Freehand and Illustrator.
  - The photographs are corrected with Adobe Photoshop (image manipulation software).
  - The page-layout is designed with QuarkXPress. The text is imported and flowed into columns. The artwork and graphics are imported, resized, cropped and placed in the layout.
  - The files are converted into HTML code and displayed on the Web.

**Your partner has the information which another newspaper – *Le Matin* – sent to Katherine Powell. Listen to your partner tell you about it and complete the fact file below.**

## Le Matin

- The hardware used to produce the newspaper:
  - computers on the network: .....
  - peripherals: .....
  - data communication systems: .....
- The software used to:
  - edit text: .....
  - produce graphics: .....
  - arrange text and pictures on the page: .....
  - design Web pages: .....

## Unit 24 Task 4 Speaking

**Complete the table on the next page by asking for information, like this:**

- What does 'COBOL' mean?
- 'COBOL' stands for ...
- When was it developed?

- In ...
- What's it used for?
- It's used for ...
- What features has it got?
- It is easy to use and it's written in English. It can handle very large data files.

**Answer your partner's questions too.**

<i>Computer language</i>	<i>Date</i>	<i>Characteristics</i>	<i>Uses</i>
COBOL ( <b>CO</b> mmon <b>B</b> usiness <b>O</b> riented <b>L</b> anguage)	1958–59	Easy to read. Able to handle very large files. Written in English.	Mainly used for business applications.
BASIC .....	.....	.....	General purpose language. Used to teach programming.
Pascal (named after .....	1970–73	Structured language with algorithmic features designed for fast execution of the object program. A fast compiler called TurboPascal was created in 1982 – very popular.	.....
LOGO	1969	.....	Designed for use in schools to encourage children to experiment with programming.
SQL (.....)	1979	Supports distributed databases, which run on several computer systems. Allows various users on a LAN to access the same database at the same time.	.....
Introduced by Oracle Corp.			

# Notes for Student B

## Unit 6 Task 4 Speaking

Listen to your partner and guess which input devices they are describing.

Now use these notes to describe two input devices to Student A.

- stationary device  
● controls the cursor and selects items on the screen  
● works like upside-down mouse  
● ball on top turned round with fingers
- graphics tool  
● lets you interact with computer  
● you move pressure-stylus across the surface of a tablet  
● creates graphics

## Unit 19 Task 6 Speaking

Look at this graph and listen to your partner's description of it.  
Ask questions so that you can complete the graph.

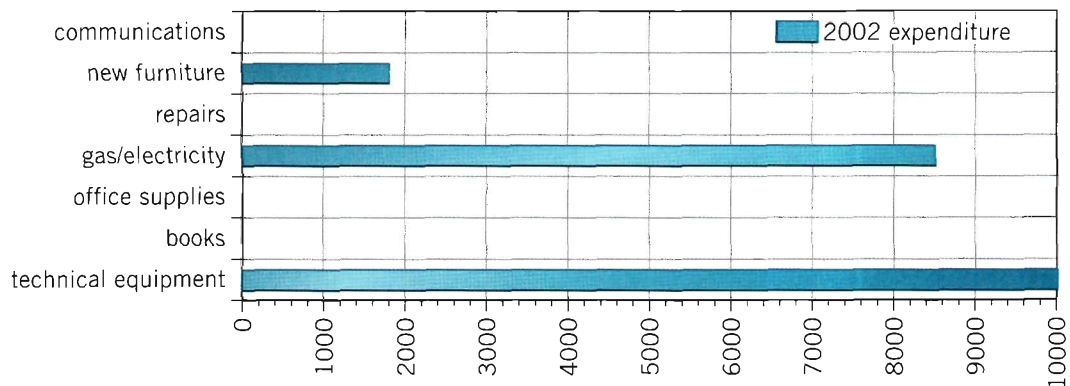

Graph 1 The 2002 expenditure of Lancashire College expressed in pounds

Now look at this graph and describe it to your partner. Then answer your partner's questions.

**Useful constructions**

- This is a two-/three-dimensional representation of ...*
- In 2002, they paid £ ... for ...*
- They spent £ ... on ...*
- As for ..., that cost them ...*

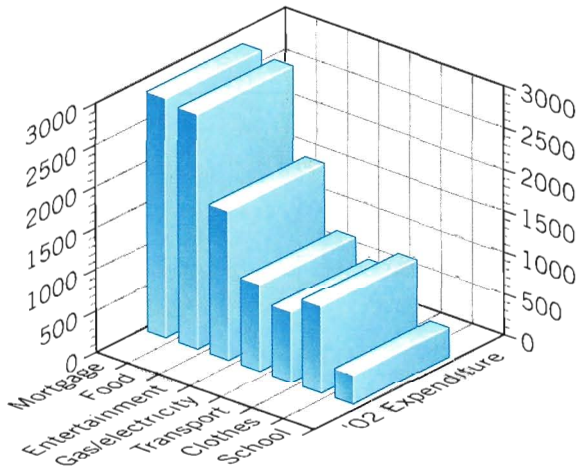

Graph 2 The 2002 expenditure of the Brown family expressed in pounds

## Unit 20 Task 5 Computers for newspapers

Your partner has the information which *El Independiente* sent to Katherine Powell. Listen to your partner tell you about it and complete the fact file below:

**El Independiente**

- The hardware used to produce the newspaper:
  - computers on the network: .....
  - .....
  - printers: .....
  - data communication systems: .....
- The software used to:
  - edit text: .....
  - create illustrations: .....
  - manipulate photographs: .....
  - design the pages: .....

**Katherine Powell also sent a similar letter to *Le Matin*.**

**Read the information they provided and tell your partner about:**

- the hardware used to produce the newspaper:
  - computers on the network
  - peripherals
  - data communication systems
- the software used to:
  - edit text
  - produce graphics
  - arrange text and pictures on the page
  - design Web pages.

# Le Matin

## ● Hardware:

- The system is based on the Ethernet network: several PCs are connected to a file server Pentium 4 running at 2 GHz with a capacity of 90 GB.
- All kinds of peripherals are interconnected over the network (scanners, laser printers, imagesetters, faxes, etc.).
- The newspaper is connected via a modem to other papers of the 'Z' group.
- Photographs are received via satellite.
- There is a web edition on our Internet site.

## ● Software:

- The text is written and edited with WordPerfect word-processing software.
- The graphics are produced on Macintosh computers with commercial packages such as Adobe Illustrator and Canvas from Deneba Systems.
- Words, pictures, graphs and tables are imported and arranged on the page by PageMaker, a DTP package.
- The web pages are designed with FrontPage, a web editor.

## Unit 24 Task 4 Speaking

**Complete the table on the next page by asking for information, like this:**

- What does 'COBOL' mean?
- 'COBOL' stands for ...
- When was it developed?
- In ...
- What's it used for?
- It's used for ...
- What features has it got?
- It is easy to use and it's written in English. It can handle very large data files.

**Answer your partner's questions too.**

<i>Computer language</i>	<i>Date</i>	<i>Characteristics</i>	<i>Uses</i>
COBOL ( <b>C</b> OMmon <b>B</b> usiness <b>O</b> riented <b>L</b> anguage)	1958–59	Easy to read. Able to handle very large files. Written in English.	Mainly used for business applications.
..... ( <b>B</b> eginner's <b>A</b> ll- purpose <b>S</b> ymbolic <b>I</b> nstruction <b>C</b> ode)	1964–65	High-level programming language. Interactive. Easy to learn. Displays error messages that help users to correct mistakes. Has a large number of dialects.	..... ..... ..... .....
Pascal (named after the famous scientist Blaise Pascal)	1970–73	..... ..... ..... .....	General purpose. Often used in colleges and universities to teach programming.
LOGO	.....	Easy to learn. Flexible — it can do maths, make lists, construct graphs, etc. Its drawing capabilities allow children to construct simple graphics programs.	..... ..... .....
<b>S</b> tructured <b>Q</b> uery <b>L</b> anguage	.....	..... ..... ..... ..... .....	A standard query language used for requesting information from a database. It allows users to specify search criteria in databases.

# Glossary

## A

**acceleration card** /ək selə'reiʃən kɑ:d/ *n*

A board that increases the speed of the processor

**access time** /'ækses taim/ *n* The average time required for the read/write head to move and have access to data; measured in milliseconds. Also known as 'seek time'

**acoustic coupler** /ə ku:stɪk 'kʌplə(r)/ *n* A type of modem which allows an ordinary telephone receiver to be used for connecting a computer to the telephone network.

**ADA** /'eɪdə/ A programming language developed for the US Department of Defense, named after Lord Byron's daughter Augusta Ada, who worked with Charles Babbage and is not unjustly described as the first programmer

**additive colour** /'ædɪtɪv 'kʌlə/ *n* A colour model on cathode ray tube displays

**address** /ə'dres/ *n* A code number that identifies the location of stored information.

**Adobe Systems** /ə'dəʊbi 'sɪstəmz/ Creators of the PostScript language and the Illustrator application, and suppliers of fonts for use with PostScript printers.

**algorithm** /'ælgərɪðm/ *n* A series of instructions or a step-by-step procedure for the solution of a problem

**alias** /'eɪliəs/ *n* A nickname that refers to a person or a list of persons on the net

**animation** /'æni'meɪʃən/ *n* The process of creating and recording images that change over time.

**applets** /'æplɪts/ *n* Small applications written in Java. When you display a Web page with Java links, a Java applet is executed automatically.

**application generator** /'æplɪ'keɪʃən dʒenəreɪtə/ *n* A tool that allows applications to be created interactively. Frequently includes a fourth-generation language and a database management system.

**application program** /'æplɪ'keɪʃən 'prəʊgrəm/ *n* A program which executes a specific task, such as word processing, database management or financial planning.

**ARPANet** /'ɑ:pənɛt/ *n* Advanced Research Projects Agency Network, developed in the early 70s by the US Department of Defense. This network is the precursor to the Internet

**arithmetic logic unit (ALU)** /ə'riθmətɪk 'lɒdʒɪk ju:nɪt/ *n* A component of the CPU which performs the actual arithmetic and logical operations asked for by a program

**arrow keys** /'ærəʊ ki:tz/ *n* Direction or cursor keys that allow the user to move the insertion point around the screen

**assembler** /ə'semblə(r)/ *n* A special program that converts a program written in a low-level language into machine code

**assembly language** /ə'sembli 'læŋgwɪdʒ/ *n* A low-level language in which instructions are the mnemonic equivalent of the code understood by the machine. Used for specialized applications where speed or compactness of code is the most important consideration

**AT-compatible** /'eɪ.ti:kəm pətəbəl/ *adj* A computer which can run the same software as the IBM PC-AT, the model introduced by IBM in 1984.

**attachment** /ə'tætʃmənt/ *n* A file that has been included as part of an e-mail message

**attributes** /'ætrɪbjʊ:ts/ *n* Characteristics that affect the visual representation of lines and polygons, e.g. line styles, rectangle colour, etc.

**authentication** /ɔ:θentɪ'keɪʃən/ *n* A security measure used to verify the user's identity on the net. When you configure the PPP program to access the Internet you have to enter a password and the user identification number

**avatar** /'ævə:tə/ *n* An object which represents a participant in a three-dimensional chat room

## B

**backbone** /'bækbəʊn/ *n* High-speed lines or connections that form the major access pathways within the Internet

**backing store** /'bækiŋ 'stɔ:/ *n* A storage device with a larger capacity but slower access time than the main memory. This type of memory is stable. It can be in the form of hard disks, floppy disks, tapes or optical disks

**back-up** /'bækʌp/ *n* A copy of data or software, usually kept in case the original disk is damaged

**back up** /'bæk 'ʌp/ *v* To copy files from one disk to another

**bandwidth** /'bændwɪðθ/ *n* The quantity of data that can be transmitted through a network. It is measured in bits per second (bps)

**batch processing** /'bætʃ 'prəʊsesɪŋ/ *n* A method of information processing in which transactions are prepared for input to the computer for processing as a single unit. There may be some delay between the occurrence of the original events and the processing of data. Compare with real time.

**baud** /'bɔ:d/ *n* A unit for measuring the rate of data transmission. One baud = 1 bit per second. Named after Baudot, a pioneer of telegraphic communication

**binary digit** /'bainəri 'dɪdʒɪt/ *n* The smallest unit of information in the binary system. 0 or 1. Also called bit

**binary system** /'bainəri 'sɪstəm/ *n* A notation system in which the base for each digital position is 2. In this system numbers are represented by the two digits 0 and 1. Thus the binary number 10 represents 2 in the decimal system, while 100 represents 4

**bit-mapped display** /'bɪtmæpt dɪs'pleɪ/ *n* A display that stores pixel information in RAM memory cells

**bookmark** /'bʊkmɑ:k/ *n* A saved link that takes users directly to a Web address. Bookmarks are also called hotlist entries or favourites

**boot** /bu:t/ *v* To start up a computer

**bridge** /'brɪdʒ/ *n* A device used to connect groups of computers.

**browser** /'braʊzə(r)/ *n* A program designed to fetch and display Web pages on the Internet

**bug** /bʌg/ *n* An error in a program

**bulletin board** /'bulətɪn 'bɔ:d/ *n* An online service that allows users to access and send information to other users quickly and easily. Any users who want to send or read messages dial up with their PC and modem combination to the central bulletin board system (BBS). Once connected they can share information and files using various facilities

**bus** /bʌs/ *n* A channel, or highway, which carries signals between units in the CPU

**byte** /baɪt/ *n* A unit of information which consists of a fixed number of bits (usually 1 byte = 8 bits). A byte can represent any value from 0 to 255. The sequence of bits in a byte represents an instruction, letter, number or any other character. Compare with kilobyte, megabyte, gigabyte, terabyte.

## C

**Cable modem** /'keɪbl məʊdem/ *n* A modem designed to operate through a cable TV line. It offers a much greater bandwidth than a telephone line.

**cathode ray tube (CRT)** /'kæθəd 'reɪ tju:b/ *n* The picture tube of the display, which is made of glass and contains a vacuum. In a monochrome monitor, the electron beam scans the screen and turns on or off the pixels that make up the black-and-white image. In a colour monitor, the

screen surface is coated with trads of red, green and blue phosphor. Three electron guns energize the phosphor dots, causing them to emit coloured light from which the picture is formed.

**cell** /sel/ *n* An intersection of a column and a row in a spreadsheet.

**central processing unit (CPU)** /ˌsentrəl ˈprəʊsesɪŋ ˌjuːnɪt/ *n* The 'brain' of the computer. Its function is to execute programs stored in the main memory by fetching their instructions, examining them and then executing them one after another. Its basic components are the control unit, the arithmetic logic unit and the registers. The CPU of a microcomputer is built into a single microprocessor chip.

**channel** /ˈtʃænl/ *n* An IRC conversation area. There are thousands of channels on the Internet.

**character** /ˈkærɪktə(r)/ *n* A symbol available on the keyboard (letter, number or blank space).

**chat** /tʃæt/ *n* A real-time interactive conversation on the Internet. See Internet relay chat.

**chip** /tʃɪp/ *n* A tiny piece of silicon containing complex electronic circuits. Chips are used to make the hardware components of a computer.

**Chooser** /ˈtʃuːzə(r)/ *n* A desk accessory supplied by Apple and used to select the printer you wish to use.

**client program** /ˌklaɪənt ˈprəʊgræm/ *n* Software running on your PC used to connect and obtain data from a server.

**client-server** /ˌklaɪənt ˈsɜːvə(r)/ *n* A system in which various client programs all connect to a central server to obtain information or to communicate.

**Clipart** /ˈklɪpɑːt/ *n* Images shipped with graphics packages.

**Clipboard** /ˈklɪpbɔːd/ *n* A holding place for text or graphics that you have just cut or copied.

**coding** /ˈkəʊdɪŋ/ *n* The process of writing instructions for a computer.

**colour palette** /ˈkɒlə ˈpælt/ *n* The collection of colours available in a system. Its size depends on the hardware.

**command** /kə ˈmɑːnd/ *n* An order which the computer can obey. Synonymous with 'instruction'.

**communications port** /kə ˈmjuːnɪ keɪfɪnz ˌpɔːt/ *n* A socket at the back of your computer for a modem.

**compact disk** /kəmˈpækt ˌdɪsk/ *n* A storage device which uses optical laser techniques and which provides mass storage capacity.

**compatibility** /kəmˈpætəˈbɪlɪti/ *n* This is said to exist between two computers if programs can be run on both without any

change; it also refers to those applications that are executed in specific types of computers, these applications are 'compatible' with the computer.

**compiler** /kəmˈpaɪlə(r)/ *n* A special program that converts a source program (written in a high-level language) into an object program (written in a lower-level language).

**compression** /kəmˈpreʃn/ *n* The process which makes computer data smaller so the information takes less space and may be transmitted in less time. Compressed files have extensions like .zip, .arj, .sit.

**configuration** /kənˌfɪgjuːreɪʃən/ *n* The physical components of a computer system.

**control unit (CU)** /kənˈtrəʊl ˌjuːnɪt/ *n* A component of the CPU which coordinates all the other parts of the computer system. This unit is also responsible for fetching instructions from the main memory and determining their type.

**cookies** /ˈkʊkiz/ *n* Small files used by Web servers to know if you have visited their site before.

**co-processor** /kəʊˈprəʊsesə(r)/ *n* A silicon chip which performs precise tasks and mathematical operations very rapidly. Sometimes it is called the 'floating-point unit' or FPU.

**cracker** /ˈkrækə(r)/ *n* An 'intruder' who breaks into computer systems for fun, to steal information, or to propagate viruses.

**crash** /kræʃ/ **1** *n* A serious failure which usually requires operator attention before the computer system can be restarted. **2** *v* When a hard disk system fails, it is said to have 'crashed'.

**cyberspace** /ˌsaɪbəˈspeɪs/ *n* A term originated by William Gibson in his novel *Neuromancer*, now used to refer to the Internet.

## D

**data** /ˈdeɪtə/ *n* Information to be processed by a computer program. Data processing is the performing of operations on data to obtain information or solutions to a problem.

**database** /ˈdeɪtəbeɪs/ *n* A file of structured data.

**database program** /ˈdeɪtəbeɪs ˈprəʊgræm/ *n* An applications program used to store, organize and retrieve a large collection of data. Among other facilities, data can be searched, sorted and updated.

**data communication system** /ˈdeɪtə kə ˈmjuːnɪ keɪʃən ˌsɪstəm/ *n* A computer system connected by telecommunications links (for data transmission).

**data transfer rate** /ˈdeɪtə ˈtrænsfə reɪt/ *n* The average speed required to transmit data from a disk system to the main

memory. Usually measured in megabits per second.

**debug** /ˈdiːbʌg ˌv/ *v* To correct program errors or 'bugs'.

**debugger** /diːˈbʌgə/ *n* A tool which lets the user follow the execution of programs one statement at a time, in order to help find errors in the code.

**decryption** /ˌdiːˈkrɪptʃn/ *n* The process of decoding (deciphering) secret data.

**default font** /ˈdɪfɔːlt ˌfɒnt/ *n* A font used by the system until another font is chosen from the menu.

**desk accessory** /ˌdesk ək ˈsesəri/ *n* A mini-application available on the Apple Menu. Examples: Calculator, Clock, Scrapbook.

**desktop** /ˈdesktop/ *n* An area of work – the menu bar and other sections of the screen.

**desktop publishing (DTP)** /ˈdesktop ˈpʌblɪʃɪŋ/ *n* The use of a computer system for all steps of document production, including typing, editing, graphics and printing.

**dial up** ˈdaɪəl ʌp/ *v* To connect to a network over phone lines using a modem and a computer.

**dialog box** /ˌdaɪələŋ ˌbɒks/ *n* A message box requiring information from the user.

**digitize** /ˌdɪdʒɪtaɪz/ *v* The process of converting information into number code that can be processed by computers.

**directory** /ˌdaɪ-, ˌdɪˈrektəri/ *n* An alphabetical or chronological list of the contents (files) of a disk. Also known as catalogue.

**disk** /dɪsk/ *n* A storage device made of flat circular plates with magnetizable surfaces. See floppy, hard and optical disks.

**disk drive** /ˌdɪsk draɪv/ *n* The electronic mechanism that actually reads what is on a disk. If we are talking about hard disks, the disk and the drive are built into a single unit (hard disk = hard drive). If we are talking about floppies, the disk drive is the slot into which you insert a floppy disk.

**dithering** /ˈdɪðərɪŋ/ *n* The process of mixing two colours to produce an approximation to another colour. By using this shading technique, the human eye will blend the colours, increasing the apparent number of colours on the screen.

**domain name** /də ˈmeɪn ˌneɪm/ *n* Internet sites are usually identified by a domain name, which consists of two or more parts separated by dots, e.g. http://www.ibm.com. The part on the left, a subdomain, is the most specific (e.g. ibm, warehouse). The part on the right, a primary domain, is the most general, this can be a country (e.g. fr for France, es for Spain, it for Italy), or the type of organization (e.g. com for commercial, org for organization, edu for

education, or net for network). An IP address (e.g. 194.179.73.2) is translated into a domain name (e.g. sendanet.es) by a Domain Name System.

**dot-matrix** /ˈdɒt mætrɪks/ *n* A regular pattern of dots; conventionally used to refer to dot-matrix printers which, instead of printing formed characters, print an array of dots. There are two main types of dot-matrix printers: the 9-pin and the 24-pin. The two most important emulations for these printers are Epson and IBM Proprinter.

**download** /ˈdaʊnləʊd/ *v* To transfer a file from one computer to another over the telephone.

## E

**edit** /ˈedɪt/ *v* To make changes and corrections to text and graphics. Well-known editing techniques are: 'select', 'undo', 'copy', 'cut' and 'paste' a portion of text.

**electronic mail (e-mail)** /ˈelektrɒnɪk ˈmeɪl/ *n* A facility which allows users to exchange messages electronically. Here is a typical e-mail address:

leo@sendanet.es

'leo' is the user name, '@' means 'at', 'sendanet' is the Internet service provider, and 'es' means the server is based in España (Spain).

**encrypt** /ɪnˈkript/ *v* To encode data so that unauthorized users can't read it.

**encryption** /ɪnˈkriptʃn/ *n* The process of encrypting. Data encryption is important for network security, particularly when sending confidential information such as credit card numbers.

**EPS format** /ɪˈpiːəs ˈfɔːmət/ *n* A file format that stands for 'Encapsulated PostScript'. It stores a file in a form that can be imported into a different file.

**execute** /ˈɛksɪkjʊːt/ *v* To perform the operations specified by a routine or instruction. Execute a program: run a program in a computer.

**expansion slots** /ɪkˈspænjən slɒts/ *n* The connectors that allow the user to install expansion boards to improve the computer's performance.

## F

**fault tolerance** /ˈfɔːlt ˌtɒlərəns/ *n* A technique to protect data from hardware failures such as disk crashes, bad controllers or the destruction of important information on a file server. Fault-tolerant systems are essential for LAN installations.

**fax** /fæks/ *n* A facsimile machine that operates by scanning a document so that the image is sent to a receiving machine which produces a copy of the original

**field** /fi:ld/ *n* A unit of information in a 'record'. In a database, information is entered via fields.

**file** /faɪl/ *n* **1** A collection of records (in a database). **2** A section of information stored on disk – a document or an application.

**file compression** /ˈfaɪl kəmˌpreʃən/ *n* The encoding of a file into a more compact format so that it occupies less disk space.

**file server** /ˈfaɪl ˌsɜːvə/ *n* The combination of a software controller and a mass storage device which allows various users to share common files and applications (in a network).

**finger** /ˈfɪŋgə/ *n* A program that helps you find people on other Internet sites.

**firewall** /ˈfaɪə wɔːl/ *n* A software and hardware device that allows limited access to an internal network from the Internet. This prevents intruders from stealing or destroying confidential data.

**firmware** /ˈfɜːmwɛə/ *n* Permanent software instructions contained in the ROM.

**flame** /fleɪm/ *n* An angry or insulting comment on a discussion group (on the Internet).

**floppy disk** /ˈflɒpi ˈdɪsk/ *n* A disk made of a flexible plastic material upon which data is stored on magnetic tracks.

**flowchart** /ˈfləʊtʃɑːt/ *n* A diagram or symbolic representation which shows the logical steps of a computer program.

**flush** /flʌʃ/ *adj* A line of type is said to be 'flush' when there is no space between it and a reference line. For example, text that is 'flush left' is aligned with the left margin of a page.

**folder** /ˈfəʊldə/ *n* A holder of documents, applications and other folders on the Macintosh desktop. Folders (similar to subdirectories in other systems) allow you to organize information in different levels.

**font** /fɒnt/ *n* The shape, style and size of a particular typeface, e.g. Times Bold at 10pt.

**resident font** /ˈrezɪdənt ˈfɒnt/ *n* A font included in a laser printer's memory. (If a font is not resident, the printer has to load it from the computer, which takes up RAM from the printer.)

**font formats** /fɒnt ˈfɔːməts/

- PostScript Type 1 & 2, scalable font formats from Adobe Systems
- TrueType, scalable font format from Apple and Microsoft.

**format** /ˈfɔːmət/ **1** *n* The layout of a document, including page numbers, line spaces, margins, paragraph alignment, headers and footers, etc. **2 format a disk** *v* To prepare a disk for use. When a disk is initialized, the operating system marks tracks and sectors on its surface.

**fragmentation** /ˈfrægmənˈteɪʃən/ *n* Disk performance can be affected by fragmentation. When the operating system cannot find enough contiguous space to store a complete file, the file is divided into several separated fragments. As disk fragmentation increases, disk efficiency starts decreasing.

**frames** /ˈfreɪmz/ *n* Subdivided areas of the screen. Some Web sites have frames or separate windows within the main window.

**freeware** /ˈfriːwɛə/ *n* Software that is available free of charge for public use.

**function key** /ˈfʌŋkʃən ˌkiː/ *n* A key on a computer keyboard which causes a specific operation to take place, other than the entry of a standard character. What function keys do depends on the program.

## G

**gateway** /ˈgeɪtweɪ/ *n* A device used to interconnect different types of networks.

**gigabyte** /ˈgɪɡəbaɪt/ *n* 1,024 megabytes.

**gigahertz** /ˈgɪɡəhɜːtʃs/ *n* A unit of one thousand megahertz used to measure processor speed.

**graphics tablet** /ˈgræfɪks ˌtæblɪt/ *n* An input device which allows the user to specify a position on the screen by using a stylus. Tablets are more accurate than other devices.

**graphical user interface (GUI)** /ˈgræfɪkəl ˌjuːzər ɪntəfeɪs/ *n* An operating environment based on graphics (windows, icons, pop-up menus), mouse and pointer, e.g. the Macintosh system, Microsoft Windows, IBM OS/2 Warp or OSF Motif.

**graphics package** /ˈgræfɪks ˌpækɪdʒ/ *n* Software that allows the user to create and run graphics programs.

## H

**hacker** /ˈhækə(r)/ *n* Someone who invades a network's privacy.

**hard disk** /ˈhɑːd ˈdɪsk/ *n* A disk made from a solid magnetic material used as a storage device. There are different versions: fixed (internal, external), removable, etc. Compare with optical disks.

**hardware** /ˈhɑːdweə/ *n* The physical units which make up a computer system. See software.

**hexadecimal system** /ˌheksəˈdesɪməl ˌsɪstəm/ *n* The notation of numbers to the base of 16. The ten decimal digits 0 to 9 are used, and in addition six more digits – A, B, C, D, E and F – to represent 10 to 15.

**high-level language** /ˌhaɪ ˈleɪvəl ˌlæŋɡwɪdʒ/ *n* A language in which each statement represents several machine code instructions, e.g. FORTRAN, COBOL, LISP, etc.

**home page** /ˈhəʊm ˈpeɪdʒ/ *n* **1** The first page of a Web site that contains links to other pages. **2** The default start-up page on which a Web browser starts.

**host** /həʊst/ *n* The computer which you contact to access the Internet.

**hyperlink** /ˈhaɪpəlɪŋk/ *n* Text, image or button that connects to other destinations on the Web. It is like an embedded Web address that you can click.

**hypermedia** /ˈhaɪpəˈmi:diə/ *n* A combination of hypertext and multimedia. A hypermedia document integrates different formats (text, graphics, sound, and video) and contains links that take you to other resources.

**hypertext** /ˈhaɪpətɛkst/ *n* Text that contains links to other documents. The codes used to create hypertext documents are called HTML. See also Web.

**hyphenation** /ˈhaɪfənˈneɪʃən/ *n* The division of words into syllables by a short dash '-' or hyphen. To produce lines of equal length, word processors hyphenate words instead of stretching word spaces too much.

## I

**icon** /ˈaɪkɒn/ *n* A small picture representing an object, process or function.

**image map** /ˈɪmɪdʒ ˌmæp/ *n* A clickable image that sends you to different Web pages depending on the area you click.

**imagesetter** /ˈɪmɪdʒˌsetə/ *n* A professional printer that generates high-resolution output on paper or microfilm.

**inch** /ɪntʃ/ *n* The equivalent of 2.54 cm, or 72/27 points.

**indentation** /ˈɪndənˈteɪʃən/ *n* This moves the edge of the text away from the margins towards the centre of the page.

**INITs** /ˈɪnɪts/ *n* System utilities activated when the computer is turned on.

**ink-jet printer** /ɪŋk dʒet ˌprɪntə(r)/ *n* A printer that generates an image by spraying tiny droplets of ink at the paper. By heating the ink within the print head, individual drops are expelled to make a matrix of dots on the paper.

**input** /ˈɪnpʊt/ **1** *n* The process of transferring information into the memory from some peripheral unit. **2** *v* To transfer data, or program instructions, into the computer.

**input devices** /ˈɪnpʊt dɪˌvaɪsɪz/ *n* Units of hardware which allow the user to enter information into the computer, e.g. the keyboard, mouse, trackball, lightpen, graphics tablet, voice recognition devices.

**integrated package** /ˈɪntəɡreɪtɪd ˌpækɪdʒ/ *n* Software which includes a family of

applications – typically spreadsheet, word processor, database and graphics and communications modules. The modules are linked by a common user interface.

**interface** /ˈɪntəfeɪs/ *n* Channels and control circuits which provide a connection between the CPU and the peripherals. See also user interface.

**internal memory** /ɪnˈtɜ:nəl ˌmeməri/ *n* See main memory.

**Internet** /ˈɪntənət/ *n* A global network of computer networks which facilitates data communication services such as e-mail, file transfer, information retrieval and newsgroups.

**Internet relay chat** /ˈɪntənət ˈrɪ:li: tʃæt/ *n* A system that allows many people to have live conversations (usually typed) simultaneously on the Internet.

**Internet telephone** /ˈɪntənət ˈtelɪfəʊn/ *n* A system that allows people to make phone calls via the Internet.

**Internet TV** /ˈɪntənət ˈti: ˈvi:/ *n* A TV set used as an Internet device.

**interpreter** /ɪnˈtɜ:prɪtə/ *n* A programming environment that executes statements directly, avoiding the need for compilation.

**Intranet** /ˈɪntrənət/ *n* An internal company network which uses public Internet software but makes the Web site only accessible to employees and authorized users.

**IP address** /aɪ ˈpi: əˈdres/ *n* A number which identifies a computer on the Internet. Every machine on the Internet has a unique IP address, e.g. 194.179.73.2

## J

**Java** /dʒɑ:və/ *n* The cross-platform programming language from Sun Microsystems for building Internet applications.

**joystick** /dʒɔɪstɪk/ *n* An input device with a vertical lever used in computer games to move the cursor around the screen.

**justification** /dʒʌstɪfɪˈkeɪʃən/ *n* The process by which the space between the words and letters in a line of type is evenly divided to produce a line that is flush with both left and right margin.

## K

**kerning** /kɜ:nɪŋ/ *n* The process of adjusting the spaces between letters to achieve even, consistent letter spacing.

**key pals** /ki:pælz/ *n* Pen pals (pen friends) that exchange e-mail messages.

**keyboard** /kɪ:bɔ:d/ *n* An input device with typewriter keys for letters, numbers and line controllers. It may also have function keys for special purposes.

**kilobit** ˈkɪləbɪt/ *n* One thousand bits; unit used to measure the bandwidth of transmission, e.g. 56 kilobits per second.

**kilobyte** /kɪləbaɪt/ *n* A unit for measuring the memory or disk space in thousands of bytes. Also called k = 1,024 bytes.

## L

**laptop** /ˈlæptɒp/ *n* A small type of portable computer.

**laser printer** /ˈleɪzə ˌprɪntə(r)/ *n* A printer that uses a laser beam to fix the ink (toner) to the paper.

**lightpen** /ˈlaɪtpen/ *n* A highly sensitive photo-electric device which uses the CRT screen as the positioning reference. The user can pass the pen over the surface of the screen to detect, draw or modify images displayed on the screen.

**link** /lɪŋk/ *n* See hyperlink.

**list server** /lɪst ˌsɜ:və(r)/ *n* See mailing list.

**load** /ləʊd/ *v* To read program instructions into the main memory.

**local area network (LAN)** /ləʊkəl ˌæriə ˈnetwɜ:k (læn)/ *n* A network contained in a relatively small area.

**login** /ˌlɒɡɪn/ *n* The act of identifying yourself when entering a network. You usually type your user name and password.

**log on** /ˌlɒɡ ˈɒn/ *v* To connect to a network, FTP site or Telnet remote system.

**log off** /ˌlɒɡ ˈɒf/ *v* To disconnect from a network or online system.

**low-level language** /ləʊ ˌlevəl ˌlæŋɡwɪdʒ/ *n* A language in which each instruction has a corresponding machine code equivalent.

## M

**machine code** /məˈʃi:n kəʊd/ *n* Binary code numbers, the only language that computers can understand directly.

**macro** /ˈmækrəʊ/ **1** An abbreviation for 'macro-instruction'. **2** A stored set of commands, control sequences or definitions that is substituted for the macro name when that name is invoked.

**mailing list** /ˈmeɪlɪŋ ˌlɪst/ *n* A system that allows people to send e-mail to one address. The messages are then distributed to all the subscribers. Mailing lists are usually discussion groups which connect people with common interests.

**mail merging** /meɪl ˌmɜ:dʒɪŋ/ *n* The process of combining a database file with a word processor to personalize a standard letter.

**mainframe** /ˈmeɪnfreɪm/ *n* The largest and most powerful type of computers. Mainframes process enormous amounts of data and are used in large installations.

**main memory** /ˌmeɪn 'meməri/ *n* The section which holds the instructions and data currently being processed; also referred to as the 'immediate access store', 'primary memory' or 'internal memory'. Microcomputers make use of two types of internal memory: RAM and ROM.

**megabit** /ˌmegəbɪt/ *n* A million binary digits; used to refer to storage devices.

**megabyte** /ˌmegəbaɪt/ *n* 1,024 kilobytes.

**megahertz** /ˌmegəhɜːts/ *n* A unit of a million cycles per second used to measure processor speed.

**menu bar** /ˌmenjuː ˈbɑː/ *n* The area at the top of the screen which allows access to the various menus.

**microchip** /ˌmaɪkrəʊˌtʃɪp/ *n* See chip

**microprocessor** /ˌmaɪkrəʊˈprəʊsesə(r)/ *n* A chip, or integrated circuit, that processes the instructions provided by the software.

**mnemonic** /nɪˈmɒnɪk/ *n* A label or abbreviation used to make words easier to remember.

**modem** /ˌmɒdəm/ *n* A device attached to a computer and the telephone line allowing access to wide networks. Standard telephone lines carry analogue signals, so the digital signals used by computers must be converted into the correct form by means of a modem

**monitor** /ˌmɒnɪtə(r)/ *n* A CRT device which displays the computer output. Monochrome monitors display one colour at a time, in contrast to colour monitors which can display many different colours at the same time.

**mouse** /maʊs/ *n* A small input device with a ball underneath that is rolled by the user to specify the position of the cursor or to make choices from the menu

**multimedia** /ˌmʌltɪˈmiːdiə/ *n* This refers to the integration of existing technologies of audio, video, animation and telecommunications with computing. Multimedia applications are also known as hypermedia.

**multitasking** /ˌmʌltɪˈtɑːskɪŋ/ *n* The execution of several tasks at the same time.

## N

**netiquette** /ˌnetɪket/ *n* Rules of etiquette ('good manners') when sending messages to a mailing list or newsgroup

**network** /ˌnetwɜːk/ *n* A system of computer devices (e.g. CPUs, printers) or 'nodes' interconnected so that information and resources can be shared by a large number of users

**newsgroups** /ˈnjuːzˌgruːps/ *n* The public discussion areas which make up Usenet

**newsreader** /ˈnjuːzˌrɪːdə/ *n* A program that reads and sends articles to newsgroups.

**node** /nəʊd/ *n* A point on a junction of communication lines in a network. In a communications network, various computer devices (nodes) are interconnected to permit information to be interchanged between those devices

## O

**object language** /ˈɒbdʒɪkt ˌlæŋɡwɪdʒ/ *n* A language or set of instructions into which a source language is translated by a compiler.

**object-oriented programming** /ˈɒbdʒɪkt ˈɔːrɪntɪd ˈprəʊɡræmɪŋ/ *n* A programming technique that allows the creation of 'objects' which can be reused, or used as the foundation of others. Used to develop complex programs, especially GUI programs

**octal system** /ˈɒktəl ˌsɪstəm/ *n* The notation of numbers using 8 as a base or radix

**offline** /ˈɒf laɪn/ *adj* Not connected to the net.

**online** /ˈɒn laɪn/ *adj* Connected to the net

**operating system** /ˈɒpəreɪtɪŋ ˌsɪstəm/ *n* The programs and routines which allow a computer to operate, it usually consists of a group of programs which coordinate the software and hardware of a computer system.

**optical character recognition** /ˈɒptɪkəl ˈkærɪktə ˌreɪkəŋ nɪʃən/ *n* Technology that allows computers to recognize text input into a system with a scanner. After a page has been scanned, an OCR program identifies fonts, styles and graphic areas

**optical disk** /ˈɒptɪkəl ˈdɪsk/ *n* A storage device in which data is recorded as microscopic 'pits' by a laser beam. The data is read by photoelectric sensors which do not make active contact with the storage medium

**optical fibre cable** /ˈɒptɪkəl ˈfaɪbə ˌkeɪbəl/ *n* A type of cable that guides light impulses at high frequencies along the glass fibre

**output** /ˈaʊtpʊt/ **1** *n* The results produced by a computer. **2** *v* To transfer information from a CPU to an output device.

**output devices** /ˈaʊtpʊt dɪˌvaɪsɪz/ *n* The units of hardware which display the results produced by the computer (e.g. plotters, printers, monitors).

## P

**page description language** /ˌpeɪdʒ dɪˈskrɪpʃən ˌlæŋɡwɪdʒ/ *n* A computer language that describes how to print the text and images on each page of the document.

**palmtop** /ˈpɑːmtɒp/ *n* A hand-held computer which is used as PC companion

**parallel port** /ˌpærəlel ˈpɔːt/ *n* An interface port on a printer used to communicate with the computer. It transmits and receives 8 bits of data side by side. Compare with serial port.

**Pascal** ˈpæsˈkæl/ A high-level language, named after Blaise Pascal

**password** /ˈpɑːswɜːd/ *n* A secret word which must be entered before access is given to a computer system.

**patterns** ˈpætənz/ *n* A menu or palette from which the user can pick the required pattern to fill shapes and draw borders

**peripherals** /pəˈrɪfərəlz/ *n* The units connected to the CPU: input devices, output devices and storage devices.

**phosphor** ˈfɒsfər/ *n* The material or substance of the CRT screen that lights up when struck by an electron beam

**pica** ˈpaɪkə/ *n* A unit of 4.23 mm used in typography

**piracy** ˈpaɪərəsɪ/ *n* The illegal copying of programs

**pixel** ˈpɪksəl/ *n* The smallest element of a display surface. In monochrome monitors, one pixel is the visual representation of a bit in the refresh buffer (the memory used for storing the picture for screen refresh). The pixel is white if the bit is 0, and black if the bit is 1. In colour monitors, each pixel can represent various bits

**platform** /ˈplætfɔːm/ *n* A type of computer system, e.g. IBM PCs and compatibles, Macintosh computers

**plot** /plɒt/ *v* To draw lines connecting the points on a graph

**plotter** ˈplɒtə(r)/ *n* A very common graphics output device which is used to make various types of engineering drawings

**plug-ins** ˌplʌɡɪnz/ *n* Special programs which extend the capabilities of a browser so that it can handle audio, video, 3-D and animation.

**point** ˈpɔɪnt/ *n* A unit used to measure font types and the distance between baselines. A point is a subdivision of a pica: there are 12 points in a pica and 72.27 points in an inch

**pointer** ˈpɔɪntə(r)/ **1** A small picture that follows the mouse movements. **2** The cursor which locates the insertion point on the screen, i.e. indicates where the next character will be displayed

**port** pɔːt/ *n* A socket or channel in the rear panel of the computer into which you can plug a wide range of peripherals: modems, fax machines, hard drives, etc

**PostScript** ˈpəʊsskrɪpt/ *n* A page description or graphics language developed by Adobe Systems Inc. A PostScript font is any font – such as Times

or Helvetica – that is defined in the PostScript language

**primary colours** /praɪməri 'kʌləz/ *n* These are red, green and blue in computers. Compare with the colours considered basic in inks (magenta, yellow and cyan)

**primitives** /'prɪmɪtɪvz/ *n* The basic shapes used to construct graphical objects: lines, polygons, etc

**printer** /'prɪntə(r)/ *n* An output device which converts data into printed form. The output from a printer is referred to as a print-out. There are various types of printers: laser, dot-matrix, ink-jet, thermal, etc.

**printer driver** /'prɪntədraɪvə(r)/ *n* A program installed to control a particular type of printer.

**program** /'prəʊgrəm/ *n* A set of instructions for solving a specific problem by computer

**programming** /'prəʊgræmɪŋ/ *n* The process by which a set of instructions is produced for a computer to make it perform a specified task. The task can be anything from the solution to a mathematical problem to the production of a graphics package.

**protocol** /'prəʊtəkɒl/ *n* A set of rules which determine the formats by which information may be exchanged between different systems.

**proxy** /'prɒksɪ/ *n* A special server which controls the traffic between the Internet and a private network. Thanks to this server all the computers of an internal network can access the Internet simultaneously. A proxy also contains security mechanisms. See also firewall

## Q

**quit** /kwɪt/ *v* To leave a program

## R

**random access memory (RAM)** /'rændəm 'æksəs 'meməri (ræm)/ *n* The part of the main memory which stores information temporarily while you are working. RAM requires a continuous power supply to retain information. Compare with ROM.

**RAM cache** /ræm 'kæʃ/ *n* A certain amount of RAM memory which can be designated to store information that an application uses repeatedly

**read only memory (ROM)** /'rɪd 'əʊnlɪ 'meməri (rɒm)/ *n* Chips of memory containing information which is present and permanent.

**real time** /'rɪəl 'taɪm/ *adj* Involving the processing of data input to a system at almost the same time as the event which

generates the data. Compare with batch processing.

**reboot** /rɪ:'bu:t/ *v* To restart the computer

**record** /'rekɔ:d/ *n* A unit of a file consisting of a number of interrelated data elements (fields)

**recording heads** /rɪ'kɔ:dɪŋ 'hedz/ *n* The read/write heads of disk drives

**refresh rate** /'rɪfref'reɪt/ *n* The number of times per second the display screen is scanned, creating the pixels. Also known as the 'scan rate' (A refresh rate of 70 Hz or more is needed if flicker is to be avoided.)

**register** /'redʒɪstə(r)/ *n* The component in the processor or other chip which holds the instruction from the memory while it is being executed

**resolution** /'rezə'lu:ʃən/ *n* The maximum number of pixels in the horizontal and vertical directions of the screen; also refers to the number of pixels per inch

**router** /'ru:tə(r)/ *n* A device used to connect various LANs

**routine** /ru:'ti:n/ *n* A piece of code which performs a specific function or task in the operation of a program or system.

**ruler icons** /'ru:lər 'aɪkɒnz/ *n* Small graphics representing different format options – tab stops, paragraph alignment, line spacing, etc. – which are displayed in rows at the top of a Windows screen

## S

**save** /seɪv/ *v* To copy information from the RAM to a disk

**scale** /skeɪl/ *v* **1** To magnify or shrink a particular font in order to use it at a range of point sizes. **2** To make an object larger or smaller in any direction

**scanner** /'skænə(r)/ *n* An input device that scans (reads) the image as a series of dots and introduces the information into the computer's memory. Flatbed scanners have a flat surface. Slide scanners work with 35 mm slides.

**Scrapbook** /'skræpbʊk/ *n* A desk accessory in which you can keep images and text. You can copy, cut and paste frequently used pictures.

**screen saver** /'skri:n seɪvə(r)/ *n* A program that darkens the screen after you have not worked for several minutes. Designed to protect an unchanging image from burning into the screen, but used more often as a status symbol

**scroll** /'skrɔ:l/ *v* To move a document in its window by using scroll bars so that text in another part of the document is visible

**search engine** /'sɜ:ʃ 'endʒɪn/ *n* A program that allows users to search a large database of Web addresses and Internet resources. Examples of search engines are Yahoo, Altavista, Lycos.

**secondary memory** /'sekəndəri 'meməri/ *n* See backing store

**sector** /'sektə(r)/ *n* A part of a track or band of a magnetic disk

**serial port** /'sɪəriəl 'pɔ:t/ *n* An interface port on a modem, mouse or printer used to communicate with the computer. It transmits and receives bits of data one after the other. Compare with parallel port.

**shareware** /'ʃeəweə/ *n* Programs that are distributed free, via an electronic bulletin board or on a disk from user groups. The programmer usually requests that you send \$5 or \$10 to him or her, but only if you like the software.

**silicon chip** /'sɪlɪkən tʃɪp/ *n* A device made up of a non-metallic semiconducting material (silicon), which contains a set of integrated circuits, with high-speed performance

**single in-line memory modules (SIMMs)** /'sɪŋɡəl ɪn laɪn 'meməri 'mɒdju:lz/ *n* Boards containing RAM chips, connected to the mainboard of the computer

**smileys** /'smajlz/ *n* Faces made from punctuation characters to express emotions in e-mail messages.

**snail mail** /'sneɪl 'meɪl/ *n* Conventional mail delivered very slowly, in contrast with e-mail.

**software** /'sɒftweə/ *n* Programs or instructions executed by the computer. See hardware

**source program** /'sɔ:s 'prəʊgrəm/ *n* A program written in a source language, i.e. a programming language which cannot be directly processed by the hardware but requires 'compilation' into an 'object program'.

**spell checker** /'spel tʃekə/ *n* A utility to correct typing mistakes. Some programs are able to correct grammar and style.

**spooler** /'spu:lə/ *n* A utility which makes it possible to send one document to the printer (by creating a temporary file for it) so that the user can work on another.

**spreadsheet** /'spredʃi:t/ *n* An application program for financial planning which allows the user to analyse information presented in tabular form, by manipulating rows and columns.

**streaming** /'stri:mɪŋ/ *v* Technique for transmitting sound and video such that it can be processed as a continuous stream.

The files are played while they are downloading.

**style** /stɑɪl/ *n* A distinguishing visual characteristic of a typeface, e.g. plain text, italic, bold, etc.

**subroutine** /ˈsʌbruːtiːn/ *n* A set of instructions which performs a specific function of the program

## T

**tags** /tægz/ *n* Codes used in an HTML document to mark the start, end or exact location of a formatting feature or a link on a Web page

**teletext** /ˈtelɪˌtekst/ *n* A method of communicating information by using TV signals. An extra signal is broadcast with the TV picture and translated into text on the screen by a decoder

**telex** /ˈteleks/ *n* An automatic exchange service which uses telegraphic equipment (e.g. teleprinters)

**Telnet** /ˈtelnet/ *n* A network program which is used to log directly into remote computer systems. This enables you to run programs kept on them and edit files directly.

**terabyte** /ˈterəbaɪt/ *n* 1,024 gigabytes.

**terminal** /ˈtɜːmɪnəl/ *n* A visual display unit where data may be input to or output from a data communications system

**thesaurus** /θɪˈsɔːrəs/ *n* A utility for searching synonyms and antonyms. Word finder

**three-dimensional (3-D)** /θriːˈdiːmənʃənəl/ *adj* 3-D drawings have depth.

**token** /ˈtəʊkən/ *n* A special unit of data which acts as a key on a Token Ring network; only the adapter in possession of the token can transmit on the network.

**track** /træk/ *n* An area marked on the surface of a disk. When a disk is initialized, the operating system divides the surface of the disk into circular tracks, each one containing several sectors. A floppy disk usually contains 80 tracks. Tracks and sectors are used to organize the information stored on disk

**trackball** /ˈtrækbɔːl/ *n* A stationary device that works like a mouse turned upside down. The ball spins freely to control the movement of the cursor on the screen.

**transceiver** /trænsˈziːvə(r)/ *n* A **transmitter** and **receiver**: a hardware component that sends and receives network signals

**transformation** /ˈtrænsfəˈmeɪʃən/ *n* The manipulation of an object by moving, rotating or scaling it.

**two-dimensional (2-D)** /tuːˈdiːmənʃənəl/ *adj* 2-D drawings have no depth (they look flat)

**typeface** /ˈtaɪpfeɪs/ *n* A set of visually related shapes for the characters of a script. A bit-mapped typeface is one where the characters are stored as images made up of dots. A bit-mapped typeface cannot be altered in size. A scalable typeface is one where the outline of the characters is stored with formulae which adjust the outline as the font is enlarged or shrunk.

**typeset** /ˈtaɪpset/ *v* To set text as type

## U

**UNIX** /ˈjuːnɪks/ *n* A popular operating system designed by Bell Laboratories in the USA and widely adopted by many manufacturers

**update** /ˈʌpˈdeɪt/ *v* To correct, add or delete information in a file and thus ensure that the file reflects the latest situation

**upgrade** /ˈʌpˈɡreɪd/ *v* To add or replace hardware or software in order to expand the computer's power

**upload** /ˈʌpˈləʊd/ *v* To send a file from one computer to another via modem

**Usenet** /ˈjuːsˌnet/ *n* A large collection of discussion areas (called 'newsgroups') on the Internet

**user-friendly** /ˈjuːzəˈfrendli/ *adj* An expression used to describe computers which are designed to be easy to use, by means of self-explanatory interaction between users and computer.

**user interface** /ˈjuːzəˈɪntəfeɪs/ *n* The standard procedures for interaction with specific computers

**utility** /ˈjuːtɪlɪti/ *n* A small program designed to improve the performance of the system. The term 'system utility' refers to a diverse field covering anything from software designed to help you back up your hard disk or locate files, to anti-virus programs or routines used by the system.

## V

**virtual interface** /ˈvɜːtʃʊəlˈɪntəfeɪs/ *n* A type of interface based on virtual reality techniques. The user puts on a head-mounted display, and uses data gloves and other devices which make you feel as if you are in a 3D world.

**virtual reality** /ˈvɜːtʃʊəl rɪˈæləti/ *n* A computer-generated space in which the user interacts with artificial objects and environments through three-dimensional computer simulation. This is done by using sensory peripherals such as data gloves and head-mounted displays to give the feeling of being immersed into an illusory, yet sensate, world.

**virus** ˈvaɪərəs/ *n* A piece of software which attaches itself to an application or file. Once you run an infected application, the virus quickly spreads to the system files and other software. Some viruses can delete files or destroy the contents of hard disks

**voxel** ˈvɒksəl/ *n* A volume element, analogous to pixels. In spatial-partitioning representations, a solid can be decomposed into cubic cells (voxels).

## W

**Web** web/ *n* A hypertext-based system by which you can navigate through the Internet. By using a special program known as a 'browser' you can find news, pictures, virtual museums, electronic magazines – any topic you can imagine. You travel through the Web pages by clicking on keywords that take you to other pages or other Web sites. It is also known as the World Wide Web or WWW

**website** ˈweb saɪt/ *n* A location on the Internet where a company puts web pages with information

**wide area network (WAN)** /waɪdˌeəriəˈnetwɜːk (wæn)/ *n* A network that extends outside a building or small area. For long-distance communications, LANs are usually connected into a WAN

**widow** /ˈwɪdəʊ/ *n* A single line ending a paragraph and appearing at the top of a printed page or column.

**window** /ˈwɪndəʊ/ *n* A rectangle on the desktop that displays information

**window-based** /ˈwɪndəʊˌbeɪst/ *adj* This refers to an application or program whose interface is based around windows.

**word processor** /ˈwɜːdˌprəʊsesə(r)/ *n* An application that manipulates text and produces documents suitable for printing

**word wrap** /ˈwɜːdˌræp/ *n* An editing facility which automatically moves a word to the next line if there is not enough space for the complete word on the current line

**workstation** /ˈwɜːksteɪʃən/ *n* A computer system which usually includes a defined collection of input and output devices.

# Acronyms and abbreviations

- ACK** positive ACKnowledgement
- ADB** Apple Desktop Bus
- ADC** Analogue to Digital Converter
- ADSL** Asymmetric Digital Subscriber Line  
Typically the upstream data flow is between 16 and 640 kilobits per second while the downstream data flow is between 1.5 and 9 megabits per second  
ADSL also provides a voice channel
- AI** Artificial Intelligence
- AIFF** Audio Image File Format
- ALGOL** ALGOrithmic Language, a problem-oriented, high-level programming language for mathematical and scientific use
- ALU** Arithmetic Logic Unit
- AMD** Advanced Micro Devices, manufacturer of microprocessors
- API** Application Program Interface
- ASCII** American Standard Code for Information Interchange
- ASF** Advanced Streaming Format, introduced by Microsoft for the transmission of real-time video and audio over the Net
- AT** Advanced Technology The AT was born in 1984 with the introduction of the IBM PC-AT. Most ATs have 286 processors
- AT&T** American Telephone & Telegraph company
- ATM 1** Adobe Type Manager **2** Automated Telling Machine
- AVI** Audio Video Interface, a video format
- BASIC** Beginner's All-purpose Symbolic Instruction Code
- Bcc** Blind carbon copy. Addresses in the Bcc: line of an e-mail will receive a copy of the message but the identity of the recipients will be kept secret
- BBS** Bulletin Board System
- BCPL** system programming language from which the language C was derived
- BIOS** Basic Input/Output System
- bit** binary digit
- bps** bits per second
- BUS** Binary Unit System
- C** A high-level language designed for system programming, usually (but not exclusively) for software development in the UNIX environment
- CAD** Computer-Aided Design
- CAE** Computer-Aided Engineering
- CAI** Computer-Assisted Instruction
- CALL** Computer-Assisted Language Learning
- CAM** Computer-Aided Manufacturing
- CASE** Computer-Aided Software Engineering
- Cc** Carbon copy. Addresses on the Cc: line of an e-mail will receive the same message
- CD** Compact Disk
- CD-R** Compact Disk-Recordable
- CD-ROM** Compact Disk-Read Only Memory
- CD-RW** CD-Rewritable
- CGA** Colour Graphics Adaptor
- CMYB** Cyan, Magenta, Yellow, Black
- COBOL** COmmon Business-Oriented Language
- COM** Computer Output on Microfilm
- cps 1** characters per second **2** cycles per second
- CPU** Central Processing Unit
- CR** Carriage Return
- CRT** Cathode Ray Tube
- CU** Control Unit
- DA** Desk Accessory
- DAC** Digital to Analogue Converter
- DAT** Digital Audiotape DAT decks are becoming the standard for professional music recording
- DBMS** DataBase Management System
- DD 1** Disk Drive **2** Double Density
- DDE** Dynamic Data Exchange
- DEC** Digital Equipment Corporation
- DivX** Digital Video Express, video compression format based on MPEG-4
- DNS** Domain Name System
- DOS** Disk Operating System
- dpi** dots per inch
- DRAW** Direct Read After Write
- DR DOS** Digital Research disk operating system
- DS disks** double sided disks
- DTP** Desktop Publishing
- DTV** Desktop Video
- DVD** Digital Video Disk (or Digital Versatile Disk)
- DVI** Device Independent
- DVI** Digital Video Interactive
- EAROM** Electrically Alterable Read-Only Memory
- ECMA** European Computer Manufacturers' Association
- EDIF** Electronic Data Interchange Format
- EGA** Enhanced Graphics Adaptor
- EOD** Erasable Optical Disk
- EPRAM** Erasable Programmable RAM
- EPS(F)** Encapsulated PostScript (file)
- FAQ** Frequently Asked Questions, a file containing answers to questions that the Internet users frequently ask
- FD** Floppy Disk
- FDD** Floppy Disk Drive
- FDDI** Fibre Distributed Data Interface
- FDHD** Floppy Disk High Density
- FORTRAN** FORmula TRANslation
- FPU** Floating-point Unit
- FTP** File Transfer Protocol
- GB** Gigabyte (1,024 megabytes)
- GCR** Group-Coded Recording (format to recognize disks, Macintosh)
- GHz** Gigahertz, equivalent to one thousand megahertz
- GIF** Graphic Interchange Format
- GNU** Gnu's Not UNIX
- GSM** Global System for mobile Communication, it allows transmission of voice and data on mobile phones
- GUI** Graphical User Interface
- HD 1** Hard Disk **2** High Density disk
- HDD** Hard Disk Drive
- HDTV** High-definition Television
- HP** Hewlett-Packard
- HTML** Hypertext Markup Language, codes used on the Web pages
- HTTP** Hypertext Transfer Protocol, the method by which Web pages are transferred from an Internet site to your PC
- Hz** Hertz (unit of frequency equal to one cycle per second), named after Heinrich Hertz
- IAC** Inter-application Communications
- IBM** International Business Machines
- IC 1** Interface Converter (Card)  
**2** Integrated Circuit
- ICR** Intelligent Character Recognition
- IDE** Integrated Drive Electronics: a standard hard disk controller
- IGES** Internal Graphics Exchange Specification
- i/f** interface
- I/O** Input/Output
- IP** Internet Protocol
- IRC** Internet Relay Chat
- ISA** Industry Standard Architecture An ISA bus is 16 bits wide
- ISDN** Integrated Services Digital Network
- ISO** International Standard Organization
- ISP** Internet Service Provider
- IT** Information Technology
- JPEG** Joint Photographic Experts' Group: standard in image compression

- k** **1** kilo, used to denote a thousand  
2 1,024 bytes
- KB** kilobyte (1,024 bytes)
- Kbps** kilobits per second
- KHz** kilohertz: 1,000 cycles per second
- LAN** Local Area Network
- Laser** Light Amplification by Stimulated Emission of Radiation
- LCD** Liquid-Crystal Display
- LIMDOW** Light Intensity Modulation/Direct Overwrite, a method that allows you to overwrite data on optical disks
- LISP** LISt Processing: high-level language used for artificial intelligence research
- LP** Linear Programming
- LQ** Letter Quality
- MB** **1** megabyte, one million bytes  
2 Mother Board
- MBPS** MegaBits Per Second
- MC** Memory Card
- MCA** Micro Channel Architecture, standard 32-bit bus
- MDA** Monochrome Display Adaptor
- MFM** Modified Frequency Modulation (format to recognize disks: IBM and compatibles)
- MHz** megahertz, one million cycles per second
- MIDI** Musical Instrument Digital Interface
- MIME** Multipurpose Internet Mail Extensions, a standard for attaching files to e-mail messages
- MIPS** Million Instructions Per Second
- MMX** Multimedia Extensions
- modem** MOdulator/DEModulator
- MP3** MPEG-1 Layer 3 Audio
- MPEG** Moving Pictures Experts' Group, standard for compressing and decompressing images
- ms** millisecond, thousandth of a second
- MS-DOS** Microsoft Disk Operating System
- MTBF** Mean Time Between Failure. Refers to the average rate of hours for a hard disk
- NAK** Negative ACKnowledgement
- NAS** Network Application Support
- NIC** Network Interface Card
- NLQ** Near Letter Quality
- NUI** Network User Identifier
- OCR** Optical Character Recognition
- OLE** Microsoft's Object Linking and Embedding standard
- OOP** Object Oriented Programming
- OROM** Optical Read Only Memory
- OS** Operating System
- OSF** Open Software Foundation
- OSI** Open System Interconnection
- PC** Personal Computer
- PCI** Peripheral Component Interconnect, a standard bus
- PDA** Personal Digital Assistant which includes an address book, a calendar, Internet access, etc
- pdf** Portable document formatted to distribute text files over the Internet, it can be read with Adobe Acrobat
- PDS** Processor Direct Slot
- PERT** Project Evaluation and Review Technique
- PGA** Professional Graphics Adaptor
- picon** picture icon
- pixel** picture element
- PHIGS** Programmer's Hierarchical Graphics Interactive Standard
- PL/I** Programming Language 1
- PMMU** Paged Memory Management Unit
- PPD** PostScript Page Description
- ppi** pixels per inch
- POP** Point of Presence, the location you dial into when you want access to the Internet
- PPP** Point to Point Protocol, allows computers to use modems and to have access to the Internet
- PROM** Programmable Read Only Memory
- PS** PostScript
- RAM** Random Access Memory
- RGB** Red, Green, Blue
- RIP** Raster Image Processor
- RISC** Reduced Instruction Set Computer
- ROM** Read Only Memory
- RS series** Requirement Specification, referring to the interconnection standards for computing devices RS232, RS422 and RS423
- SCSI** Small Computer System Interface
- SIMMs** Single In-line Memory Modules: circuit boards which contain RAM chips
- SMS** Short Message Service which allows you to send short text messages with maximum 160 characters to GSM mobile phones worldwide
- SMTP** Simple Mail Transfer Protocol
- SNA** System Network Architecture: data network protocol developed by IBM
- SQL** Structured Query Language
- TB** terabyte one million megabytes
- TCP/IP** Transmission Control Protocol/Internet Protocol, the language used for data transfer on the Internet
- TELEX** TELEprinter EXchange
- TIFF** Tagged Image File Format the kind of graphics-file format created by a scanner
- TFT** Thin Film Transistor In a TFT display, each pixel is produced by three tiny transistors, one each for red, green and blue. This allows for very clear and stable pictures
- TOS** Tramiel Operating System
- UMTS** Universal Mobile Telecommunications System, used by 3G mobile phones
- URL** Uniform Resource Locator, an address of a Web site's location on the Internet
- USB** Universal Serial Bus
- VAT** Value Added Tax
- VAX** Virtual Address eXtension
- VDI** Video Display Terminal
- VDU** Visual Display Unit
- VGA** Video Graphics Array
- VMS** Virtual Memory System
- VRAM** Video Random Access Memory, a common type of video card memory for colourful graphics
- VRML** Virtual Reality Modelling Language
- WAN** Wide Area Network
- WAP** Wireless Application Protocol which enables mobile phones to access the Internet
- WFW** Windows for Workgroups
- WIMP** Window, Icon, Mouse and Pointer
- WORM** Write Once/Read Many
- WP** Word Processor
- WWW** World Wide Web
- WYSIWYG** What You See Is What You Get
- XGA** eXtended Graphics Array
- XT** eXtended Technology The XT was born in 1983 with the launch of the IBM PC-XT

# Trademarks

We have made every effort to supply trademark information about brand names and products mentioned in this book.

The following are registered trademarks® or trademarks™ of Adobe Systems, Inc.: PostScript, Adobe Type Manager (ATM), Adobe Illustrator, Adobe Photoshop, PageMaker, Acrobat Reader

The following are registered trademarks® or trademarks™ of Advanced Micro Devices, Inc: AMD, Athlon.

The following are registered trademarks® or trademarks™ of Apple Computer, Inc.: Apple Macintosh, iMac, iBook, iMovie, MAC OS, Power Macintosh, LocalTalk, QuickTime, TrueType, AppleTalk.

The following are registered trademarks® or trademarks™ of Compaq Computer Corp: Compaq, Alpha, DECTalk Express.

The following are registered trademarks® or trademarks™ of Hewlett-Packard Company: HP, Hewlett-Packard, LaserJet, Vectra

The following are registered trademarks® or trademarks™ of Intel Corporation: Intel, 286, 386, 486, Pentium, Pentium II, Pentium III, Pentium 4.

The following are registered trademarks® or trademarks™ of International Business Machines Corporation: IBM, PC XT, AT, PowerPC, Token Ring, OS/2 Warp, VGA, RISC

The following are registered trademarks® or trademarks™ of International Typeface Corporation: Zapf Chancery, Zapf Dingbats, Bookman, Symbol

The following are registered trademarks® of Iomega: Jaz, Zip.

The following are registered trademarks® or trademarks™ of Linotype-Hell AG: Courier, Helvetica, Palatino

The following are registered trademarks® or trademarks™ of Macromedia: Dreamweaver, Freehand, Shockwave.

The following are registered trademarks® or trademarks™ of Microsoft Corporation: Microsoft, MS ACCESS, MS-DOS, MS Excel, MS Internet Explorer, MS NetMeeting, MS Outlook Express, MS Powerpoint, Windows '98, 2000, Millennium, NT, XP, Media Player.

The following are registered trademarks® or trademarks™ of Motorola, Inc.: Motorola 68040, PowerPC.

The following are registered trademarks® or trademarks™ of Sun Microsystems, Inc.: Sun, UltraSPARC, Java, Solaris.

Amazon is a trademark of Amazon.com, Inc.

AT&T is a trademark of American Telephone & Telegraph Global Information Solutions

Canvas is a trademark of Deneba Systems

Cyberpatrol is a trademark of SurfControl, Inc.

Dell is a trademark of Dell Corp

eBay is a trademark of eBay Inc.

Epson is a trademark of Epson Ltd.

Ericsson is a trademark of Telefonaktiebolaget LM Ericsson.

Ethernet is a registered trademark of Xerox Corporation

Eudora is a trademark of Qualcomm Incorporated

Kodak is a trademark of Kodak Company.

Linux is a trademark of Linus Torvalds

mIRC for Windows is a shareware program made by Khaled Mardem-Bey.

Netscape Communicator is a trademark of Netscape Communications Corp.

Nisus Writer is a trademark of Nisus Software, Inc

Nokia is a trademark of Nokia Corp

Palm OS is a trademark of 3Com's Palm Computing

Polywell is a trademark of Polywell, Inc.

Psion is a trademark of Psion PLC.

QuarkXPress is a trademark of Quark, Inc

RealAudio and RealPlayer are trademarks of RealNetworks, Inc

Stuffit is a trademark of Aladin Systems, Inc.

SQL is a trademark of Oracle Corp

Toshiba is a trademark of Toshiba Corp

UNIX is a trademark of UNIX System Laboratories, Inc.

WordPerfect is a trademark of Corel Corp.

Yahoo is a trademark of Yahoo Inc.

Trademarks are the property of their respective companies.

# Infotech

## English for computer users

### Student's Book **Third Edition**

Santiago Remacha Esteras

**Infotech** is a comprehensive course for intermediate level learners who need to be able to use the English of computing for study and work.

Thoroughly revised and updated to take into account the fast moving world of computers and multimedia, it does not, however, require a specialist knowledge of computers on either the part of the student or teacher.

The 30 units are organized into seven thematically linked sections and cover a wide range of subjects.

Key features of the Student's Book include:

- development of all four skills
- a wide variety of tasks and styles of presentation to engage the learner
- authentic reading texts from the world of computing
- a systematic approach to language development

- emphasis on vocabulary acquisition and word-building techniques
- a comprehensive glossary of terms
- grammar reference sections
- new internet activities for students to explore relevant websites

**Infotech** consists of:

- Student's Book
- Teacher's Book
- Audio Cassette
- Audio CD
- Workbook

Visit the Infotech website at [www.cambridge.org/elt/infotech](http://www.cambridge.org/elt/infotech)

**CAMBRIDGE**  
UNIVERSITY PRESS  
[www.cambridge.org](http://www.cambridge.org)

ISBN 0-521-75428-3



9 780521 754286